

MIR7011-4

Szklarnia poliwęglanowa
Instrukcja montażu i obsługi

PL EN

Polycarbonate Greenhouse
Assembly and maintenance

Producent:
Mirpol sp. z o.o.
ul. Ciasna 3, 35-232 Rzeszów
biuro@mirpol.rzeszow.pl
www.mirpol.rzeszow.pl
Made in China

Mirpol

SPIS TREŚCI

Wprowadzenie.....	2
Wskazówki dotyczące bezpieczeństwa	2
Zasady użytkowania	2
Zawartość opakowania	3
Lista części szklarni wraz z fundamentem	3
Zestawienie części szklarni – płyty komorowe	5
Bardzo ważne procedury postępowania podczas montażu	6
Montaż fundamentu	7
Montaż okien dachowych	9
Montaż drzwi	11
Montaż ściany czołowej z otworem drzwiowym	13
Wstawianie drzwi	15
Montaż ścian bocznych	17
Montaż ściany tylnej	19
Montaż końcowy stelażu	21
Montaż profili dachowych	24
Wstawianie okien dachowych	26
Wstawianie płyt ściennych	27
Mocowanie rynny	30

CONTENTS

Introduction.....	2
Safety information	2
Terms of use	2
Package contents.....	3
Overview of the greenhouse components including foundation	3
Overview of the greenhouse components - chambered panels ..	5
Important assembly procedures	6
Foundation assembly	7
Skylight assembly.....	9
Door assembly.....	11
Front wall with door opening assembly.....	13
Door installation.....	15
Side wall assembly	17
Back wall assembly	19
Final frame assembly.....	21
Roof profiles assembly	24
Skylight installation	26
Wall panels installation.....	27
Gutter installation	30

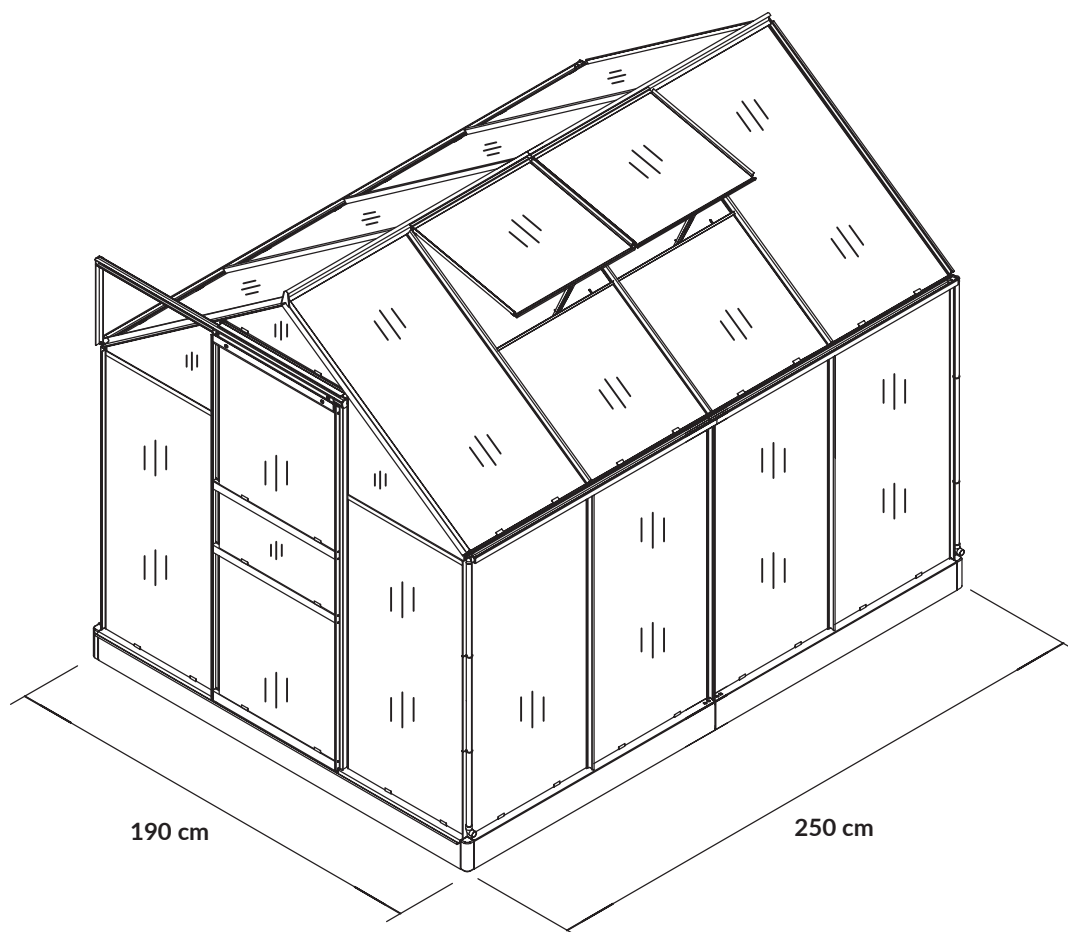

WPROWADZENIE

Drogi Kliencie, gratulujemy zakupu tego wysokiej jakości produktu!

Abyś mógł jak najdłużej cieszyć się swoim nowym produktem, prosimy o uważne przeczytanie instrukcji obsługi / instrukcji użytkownika oraz wszystkich informacji dotyczących bezpieczeństwa przed jego użyciem. Instrukcję użytkownika należy zachować, aby w każdej chwili móc przypomnieć sobie funkcje i sposób montażu produktu. W ramach ciągłego rozwoju produktów zastrzegamy sobie prawo do wprowadzania zmian technicznych służących ulepszeniu.

W związku z tym ilustracje mogą się różnić.

Produkt należy pozostawić tylko osobom, które dokładnie zapoznały się z instrukcją obsługi.

Prosimy o dokładne przestrzeganie instrukcji dotyczących pielęgnacji i konserwacji, aby zapewnić optymalną żywotność produktu i bezpieczeństwo podczas obsługi.

W przypadku pytań dotyczących produktu prosimy o kontakt.

⚠ WSKAZÓWKI DOTYCZĄCE BEZPIECZEŃSTWA

Aby uniknąć nieprawidłowego działania, uszkodzenia i uszczerbku na zdrowiu, należy przestrzegać następujących instrukcji bezpieczeństwa:

- Nie przechowywać żadnych łatwopalnych cieczy (benzyna, propan itp.) i nie używać żadnych otwartych źródeł zapłonu (papierosy, ruszty, kominki itp.) w bezpośrednim sąsiedztwie lub w jego pobliżu.
- Przed przystąpieniem do montażu należy zasięgnąć informacji o przepisach budowlanych w określonym urzędzie.
- Nie wieszaj żadnych przedmiotów na dachu.
- Produkt nie jest przeznaczony dla dzieci ani do trzymania zwierząt.
- Małe części i plastikowe torby należy przechowywać poza zasięgiem dzieci.
- Istnieje ryzyko obrażeń ciała i szkód materialnych z powodu nieprawidłowego montażu poszczególnych części.

ZASADY UŻYTKOWANIA

- Ten produkt powinien być używany tylko na twardym, równym podłożu.
- Nie używaj elektronarzędzi do montażu tego produktu.
- Użytkowanie zgodne z przeznaczeniem obejmuje również przestrzeganie instrukcji. Jakiegokolwiek użycie wykraczające poza ten zakres (np. użycie siły) lub nieautoryzowane zmiany (np. przeróbka) mogą spowodować zagrożenie i są uważane za niewłaściwe.
- Produkt jest przeznaczony wyłącznie do użytku prywatnego, a nie do celów komercyjnych.
- Nie używaj tego produktu, jeśli brakuje jakiegokolwiek części, jest ona uszkodzona lub zużyta.
- Jeśli zgłaszane są silne wiatry i burze, zalecamy użycie zestawu kotwiczowego (brak w zestawie).
- Producent nie odpowiada za szkody spowodowane skutkami natury.
- Natychmiast usuwaj z dachu zalegający śnieg.
- Nigdy nie używaj ściernych ani chemicznych środków czyszczących.

INTRODUCTION

Dear customer, congratulations on the purchase of this high-quality product!

In order for you to enjoy your new product for as long as possible, please read the manual all safety information carefully before usage. Please keep the manual for future reference. As part of ongoing product development, we reserve the right to make technical changes for the purpose of improvement.

Therefore, illustrations may vary.

Do not leave the product under the care of people who have carefully read the manual.

Please follow the care and maintenance instructions carefully to ensure optimum product life and safety.

If you have any questions about the product, please contact us.

⚠ SAFETY INFORMATION

To avoid malfunctions, damage and injury, observe the following safety instructions::

- Do not store any flammable liquids (petrol, propane, etc.). Do not use any open sources of ignition
- (cigarettes, grates, fireplaces, etc.) in or near the immediate vicinity.
- Prior to installation, it is necessary to obtain information about the building regulations at the relevant
- authority.
- Do not hang any objects on the roof.
- The product is not intended for children or for keeping pets.
- Keep small parts and plastic bags out of the reach of children.
- There is a risk of personal injury and property damage due to incorrect assembly of individual parts.

TERMS OF USE

- The product should only be used on a firm, level surface.
- Do not use power tools to assemble the product.
- Intended use also includes following the manual. Any use outside this scope (e.g. use of force) or
- unauthorised modifications (e.g. alteration) may cause a safety hazard and is considered
- inappropriate.
- The product is intended for private use only and not for commercial purposes.
- Do not use the product if any part is missing, damaged or worn out.
- If strong winds and storms are reported, we recommend the use of an anchor kit (not included).
- The manufacturer is not responsible for damage caused by the forces of nature.
- Remove lingering snow from the roof immediately.
- Never use abrasive or chemical cleaning agents.

ZAWARTOŚĆ OPAKOWANIA

Rozpakuj wszystkie części i elementy zestawu i umieść je na wierzchu pudełka lub innej czystej powierzchni. Sprawdź zawartość i kompletność dostawy. Późniejsze reklamacje nie mogą zostać przyjęte. Uważaj, aby nie zarysować podłogi.









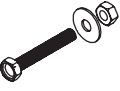

ZESTAWIENIE CZĘŚCI SZKLARNI WRAZ Z FUNDAMENTEM:



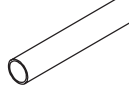
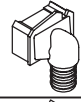

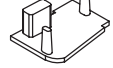
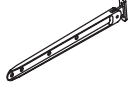

PACKAGE CONTENTS

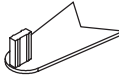
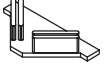
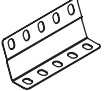
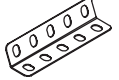
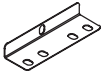
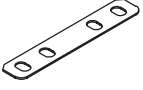

Unpack all parts and place them on top of a box or other clean surface. Check the contents and completeness of the set. Be careful not to scratch the floor.

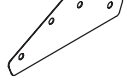
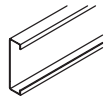
OVERVIEW OF THE GREENHOUSE COMPONENTS INCLUDING FOUNDATION:

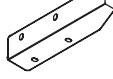
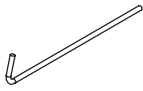
NR. NO.	Część Part	Rozmiar Size [mm]	Ilość Quantity	NR. NO.	Część Part	Rozmiar Size [mm]	Ilość Quantity	NR. NO.	Część Part	Rozmiar Size [mm]	Ilość Quantity	
1A		1215	4X	7A		1830	2X	18B		595	2X	
1B		1130	1X	7B		1300	4X	19B		520	4X	
1C		1130	1X	7C			594	2X	20B		595	2X
1D		1130	1X	7D		1300	2X	21A		603	5X	
1E		1130	1X	7K		625	16X					
2A		1640	1X	8B		1220	2X					
2B		1640	1X	8C		1220	2X					
3A		1665	1X	9B		1220	2X					
3B		1665	1X	10A		635	2X					
3C		1215	6X	11A		625	1X					
3D		1115	6X	12A		610	1X					
4B		1830	1X	13A		1250	1X					
4C		1220	2X	14A		380	1X					
4D		1220	2X	15A		1600	2X					
5A		1830	1X	16A		625	2X					
6A		619	1X	17A		625	1X					





NR. NO.	Część Part	Rozmiar Size [mm]	Ilość Quantity
2			1X
3		M6*40	25X
4			2X
5		M6*10	202X
6		M3*20	16X
7		M3*10	12X
8			4X
9			2X
10			2X
11			1X
13			2X
14			210X
15			4X
16			8X
17			74X

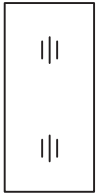

NR. NO.	Część Part	Rozmiar Size [mm]	Ilość Quantity
18			2X
19			4X
20			2X
21			1X
22			2X
23			2X
24			9X
25			4X
26			4X
27-1		1830	2X
27-2		1220	4X
28			4X
29			14X
30			4X
31			14X
32			2X

NR. NO.	Część Part	Rozmiar Size [mm]	Ilość Quantity
33			6X
35			202X

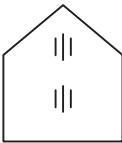
ZESTAWIENIE CZĘŚCI SZKLARNI - PŁYTY KOMOROWE:

OVERVIEW OF THE GREENHOUSE COMPONENTS -
CHAMBERED PANELS:

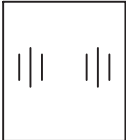
A4		603* 1210	13X
D4		603* 590	2X
F4		603* 655	1X
H4		620* 230	1X
X4		603* 440	4X

B4		603* 1120	6X
E4		595* 550	2X
G4		620* 240	1X
I4		620* 600	2X

⚠ BARDZO WAŻNE PROCEDURY POSTĘPOWANIA PODCZAS MONTAŻU

- Wszystkie części są dopasowywane do siebie automatycznie i zaprojektowane tak, aby wszystkie idealnie do siebie pasowały.
- Aby upewnić się, że wszystkie części do siebie pasują, bardzo ważne jest, aby dokręcić śruby ramy aluminiowej dopiero po zakończeniu montażu płyt ściennych. Przed montażem rusztowania należy tylko luźno dokręcić wszystkie śruby.
- Otwory w profilach aluminiowych są owalne, dlatego by w razie potrzeby, wszystkie części ramy aluminiowej można było przesunąć / dopasowywać do siebie po zainstalowaniu wszystkich płyt ściennych. Dopiero wtedy należy mocno dokręcić wszystkie śruby!
- Ze względu na gabaryty produktu zalecamy montaż w miejscu, w którym będzie używany później.
- Aby uniknąć uszkodzeń, produkt powinien być składany przez co najmniej dwie osoby.
- Upewnij się, że masz pod ręką odpowiednie narzędzia oraz że masz dużo miejsca i czyste, suche miejsce do montażu.
- Podczas montażu trzymaj małe dzieci z daleka. Uwaga, ryzyko obrażeń!
- W razie potrzeby użyj odpowiedniej drabiny.
- Poświęć wystarczająco dużo czasu na montaż i nie przerywaj po rozpoczęciu. Szklarnia zbudowana nie do końca może zostać uszkodzona lub zniszczona z powodu pogody.
- Prosimy o dokładne przestrzeganie wszystkich etapów montażu (należy pamiętać, że poniższe obrazy nie odzwierciedlają rzeczywistej skali).

⚠ IMPORTANT ASSEMBLY PROCEDURES

- All parts are fitted together automatically and designed to all fit together perfectly.
- To ensure that all parts fit together, it is very important to tighten the screws of the aluminium frame only after the wall plates have been assembled. Loosely tighten all screws only before assembling the scaffolding.
- The holes in the aluminium profiles are oval, so that, if necessary, all parts of the aluminium frame can be moved/adjusted after all the wall panels have been assembled. Only then tighten all screws firmly!
- Due to the size of the product, we recommend that it is assembled where it will be later used.
- To avoid damage, the product should be assembled by at least two people.
- Make sure you have the right tools and plenty of space as well as a clean, dry place for assembly.
- Keep small children away during assembly. Caution, risk of injury!
- Use a suitable ladder if necessary.
- Take sufficient amount of time for the assembly and do not stop once you have started. An incomplete greenhouse can be damaged or destroyed by the weather.
- Please follow all assembly steps carefully (please note that the images below do not reflect the actual scale).

MONTAŻ FUNDAMENTU:

Przed budową szklarni należy odpowiednio przygotować odpowiedni fundament (zawarty w opakowaniu).



Podłoże musi być twarde i równe. Szklarnia będzie mogła stać trwale i stabilnie tylko wtedy, gdy zostanie dokładnie wyrównana w pionie i poziomie za pomocą poziomicy. Nawet przy lekko nachylonych ścianach mogą się one prawidłowo nie utrzymać w wyznaczonych prowadnicach i łatwo mogą zostać uniesione z mocowań przez wiatr.

Szklarnia musi koniecznie zostać zakotwiczona w ziemi. Duża powierzchnia szklarni równa się z dużym obszarem dla ataku wiatru, który może prowadzić do poważnych obrażeń i / lub szkód materialnych.



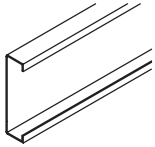
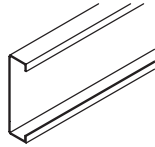
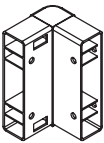
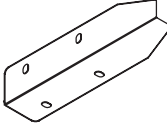
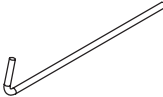
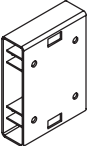

FOUNDATION ASSEMBLY:

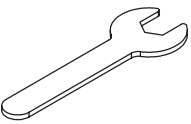
Before constructing the greenhouse, a suitable foundation (included in the package) must be properly arranged. The foundation must be firm and level. The greenhouse will only be able to stand firmly and stably if it is accurately aligned vertically and horizontally with a spirit level. Even slightly tilted walls may not hold properly in the designated guideways and can easily be lifted by the wind.

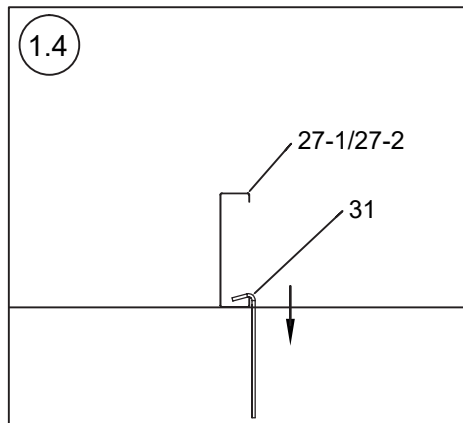
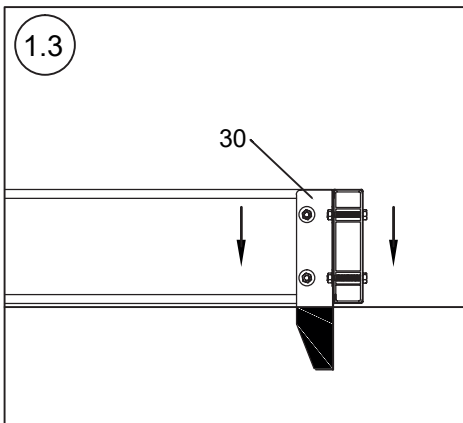
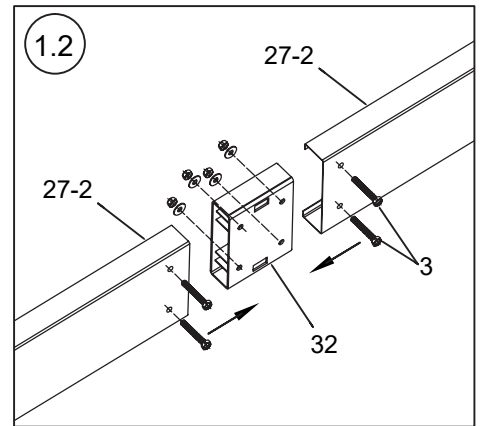
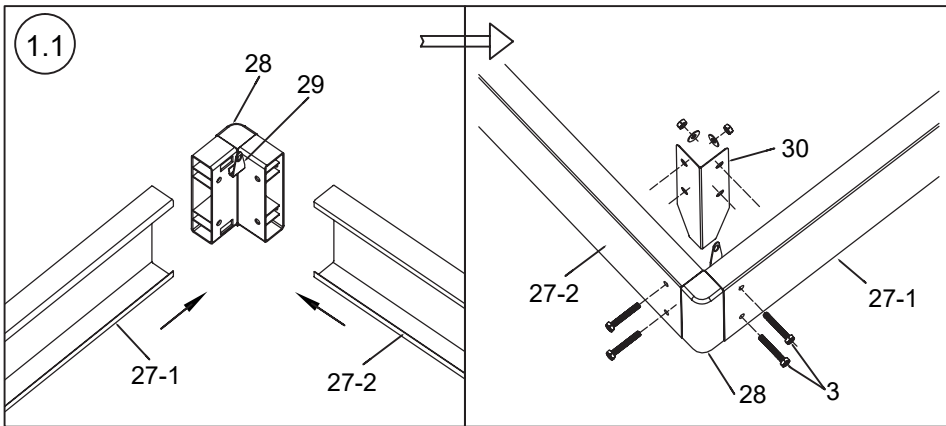
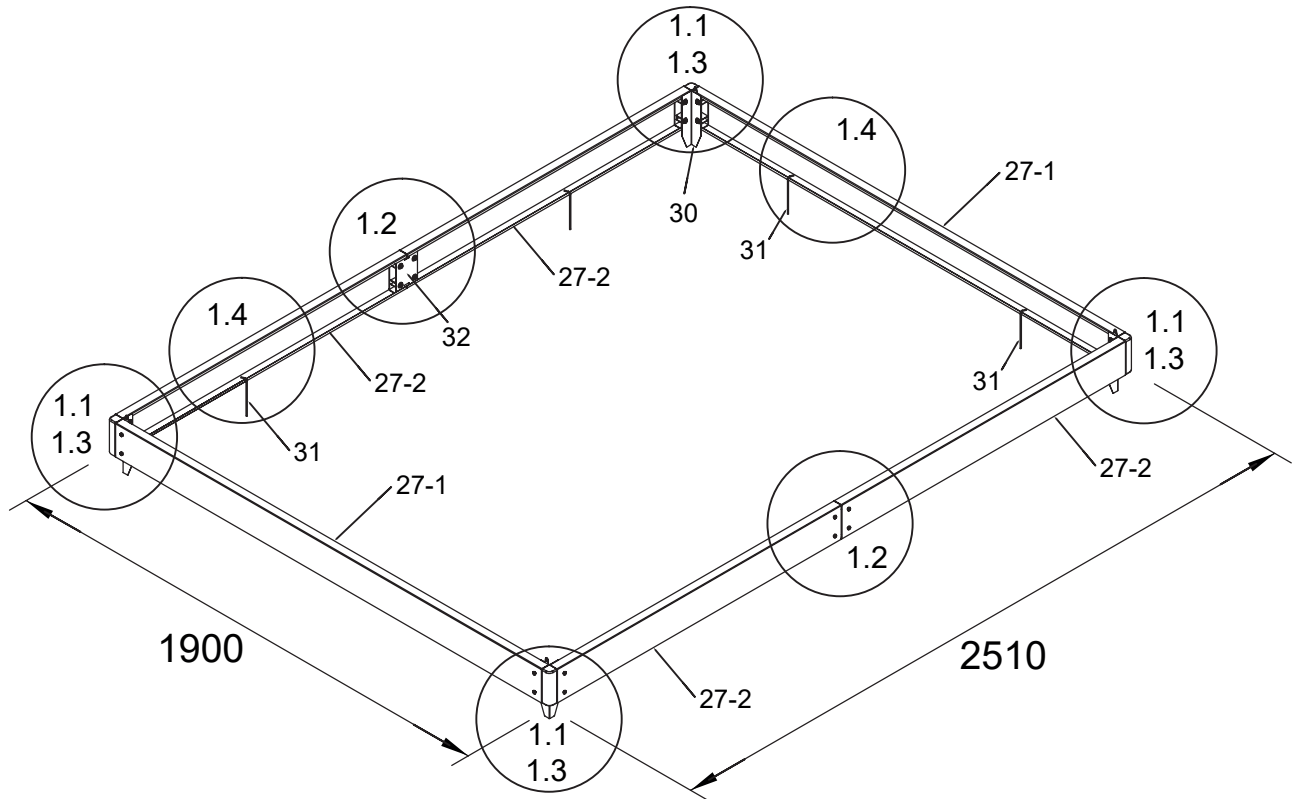
The greenhouse must necessarily be anchored in the ground. The large surface area of the greenhouse equates to a large area for wind impact, which can lead to serious injury and/or property damage.

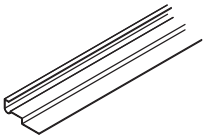
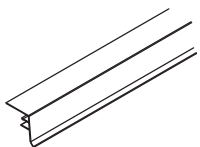
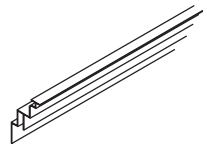
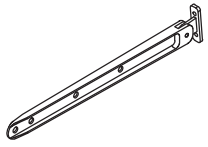
27-1		1830	2X	27-2		1220	4X
28			4X	30			4X
31			10X	32			2X
3		M6*40	24X	29			4X
4			2X				

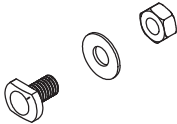

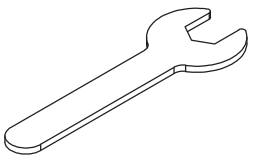
18B		595	2X	19B		520	4X
20B		595	2X	13			2X
E4		595*550	2X	5		M6*10	8X
7		M3*10	4X	4			2X

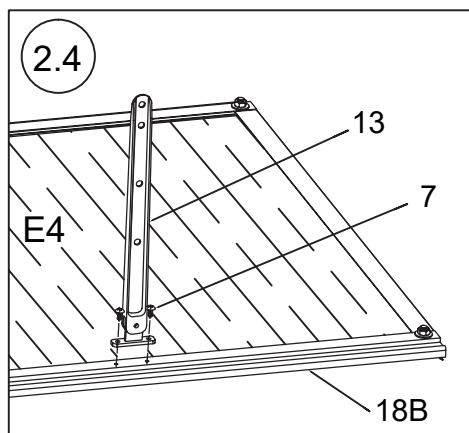
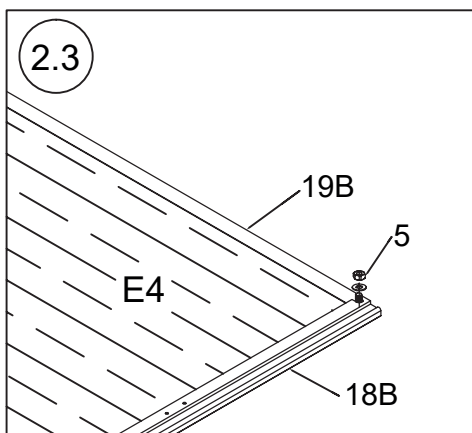
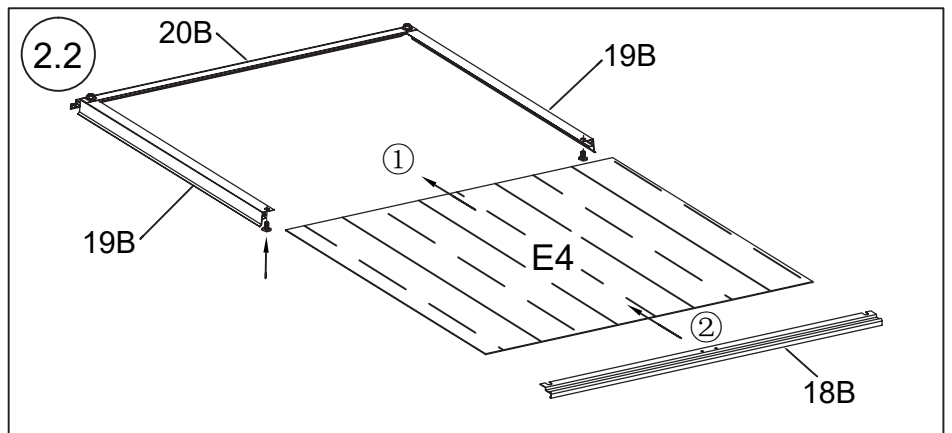
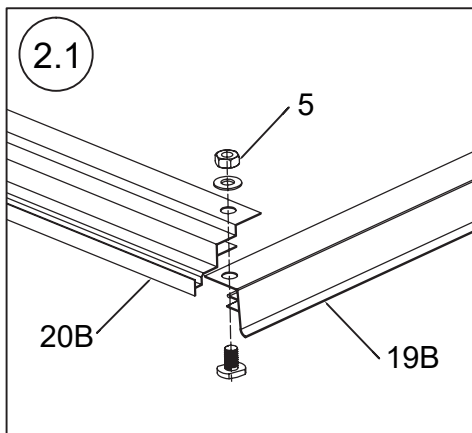
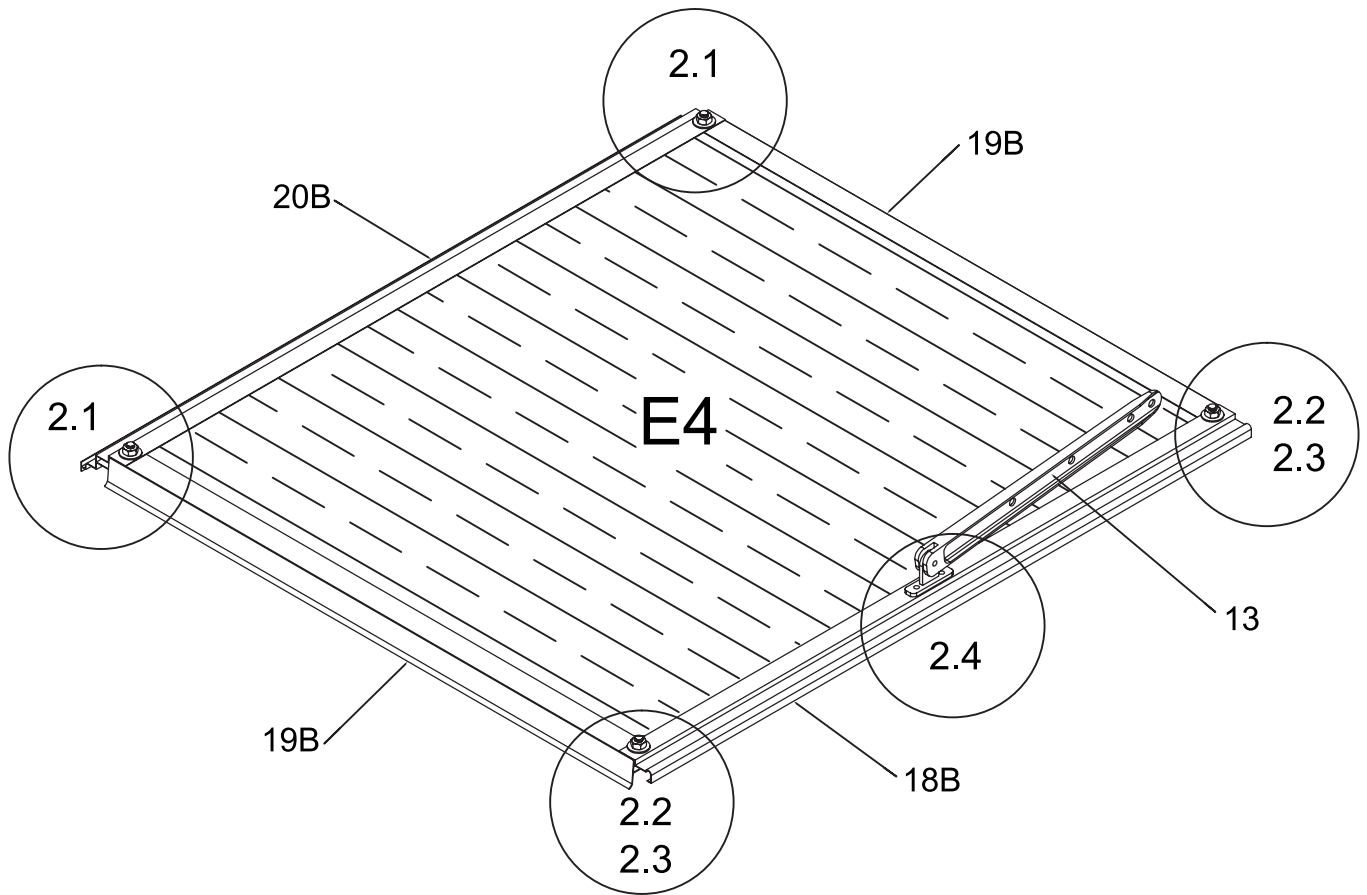

MONTAŻ DRZWI:

DOOR ASSEMBLY:

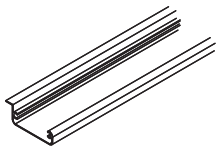
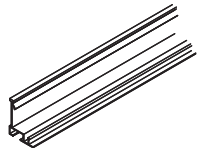
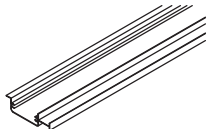
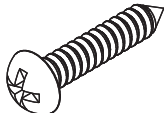
11A		625	1X
15A		1600	2X
17A		625	1X
6		M3*20	16X

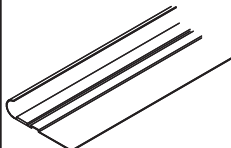
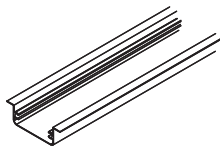
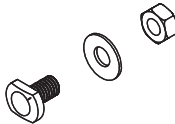
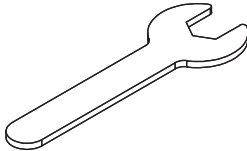
12A		610	1X
16A		625	2X
5		M6*10	2X
4			2X



Złożyć drzwi i odłożyć na bok do późniejszego wykorzystania.
Należy pamiętać, że na tym etapie nie trzeba montować poszczególnych płyt.

Assemble the door and put it aside for later use.
Note that the individual panels do not need to be assembled at this stage.

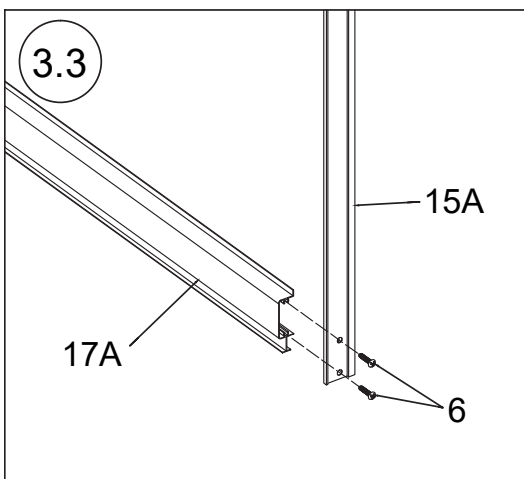
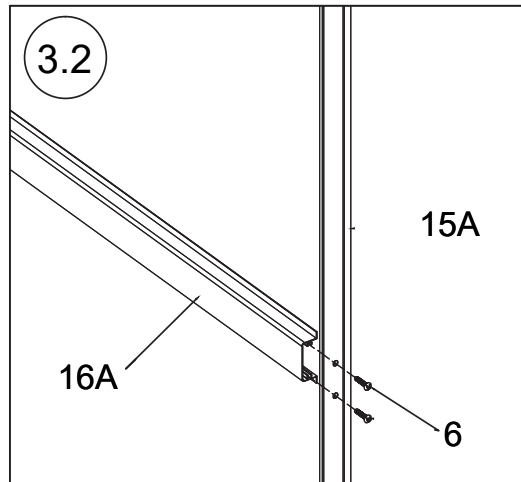
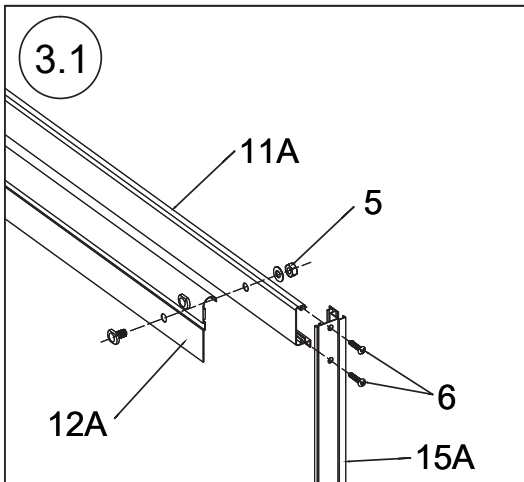
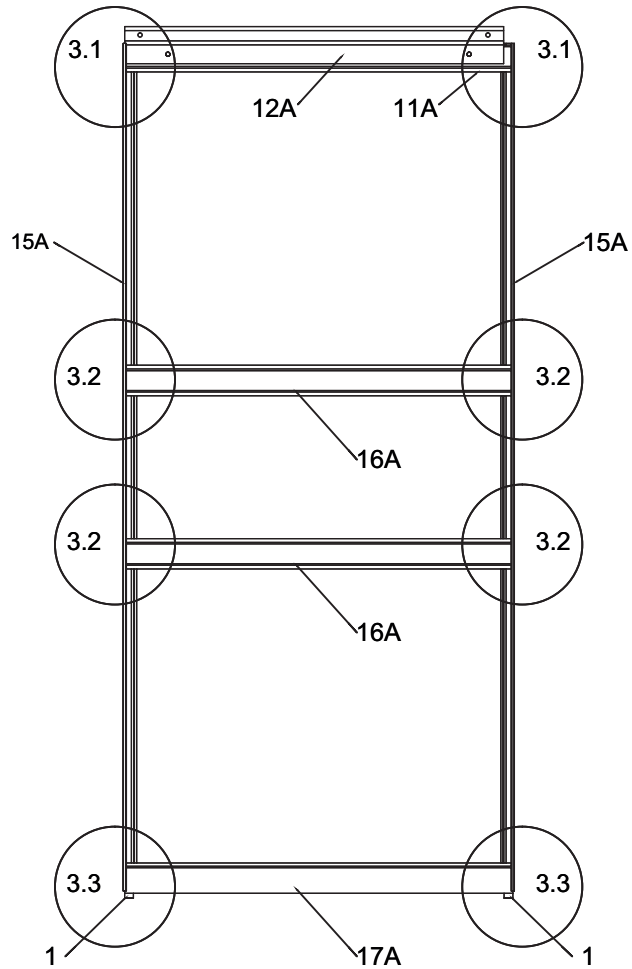

Połącz profile 12A i 11A z profilami bocznymi 15A. Użyj do tego śrub 6. Połącz profile 12A i 11A za pomocą śrub i nakrętek 5.
Przymocuj dwa profile 16A do bocznych profili 15A. W tym celu należy użyć śrub 6.
Przed przykręceniem dolnej listwy 17A do profili bocznych 15A za pomocą wkrętów 6 należy upewnić się, że prowadnica drzwi 1 została włożona.

Connect profiles 12A and 11A with side profiles 15A with screws 6. Connect profiles 12A and 11A with screws and nuts 5.
Attach two profiles 16A to the side profiles 15A with screws 6.
Before screwing the bottom moulding 17A to the side profiles 15A using screws 6, make sure that the door

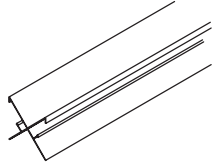
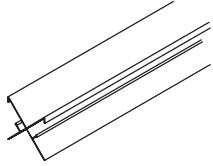
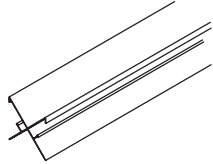
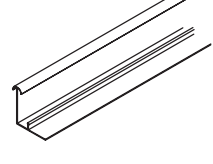
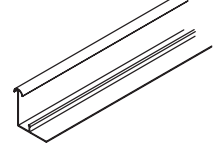
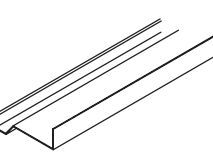
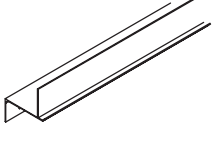
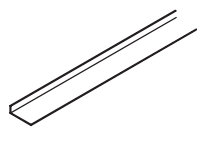
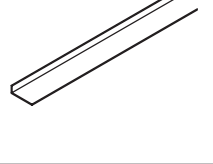
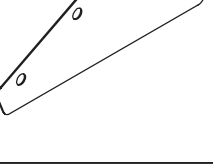
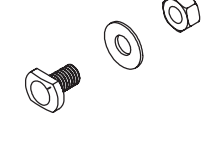
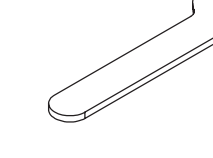
1A		1215	2X	1B		1130	1X
1C		1130	1X	2A		1640	1X
2B		1640	1X	5A		1830	1X
6A		619	1X	7C		594	2X
7D		1300	2X	26			2X
5		M6*10	18X	4			2X

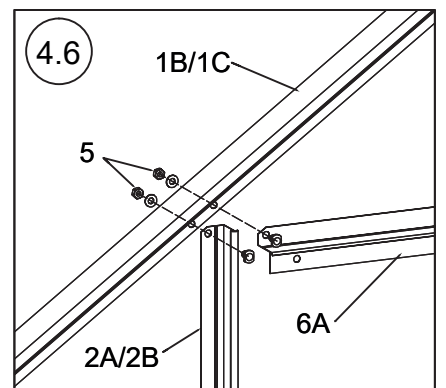
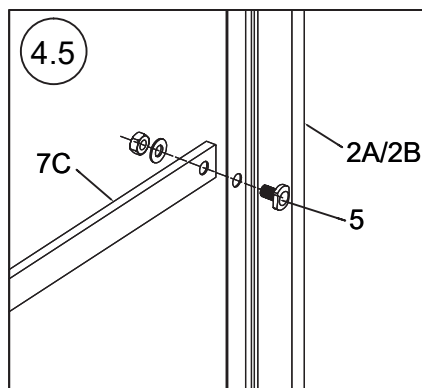
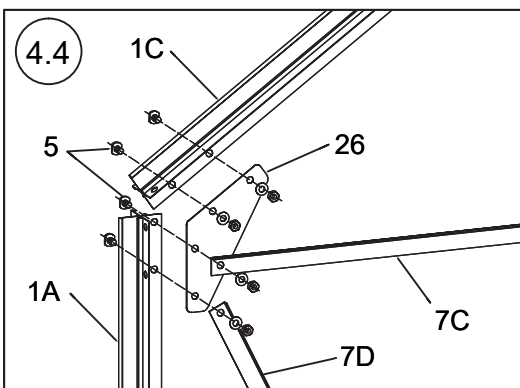
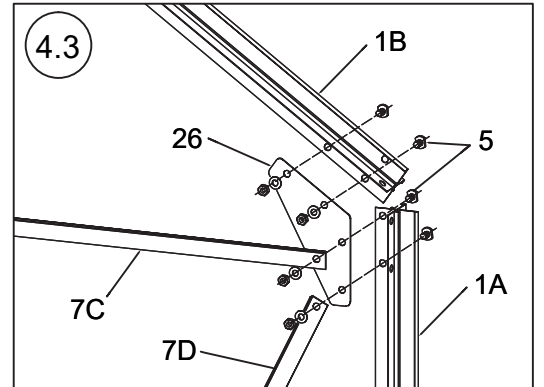
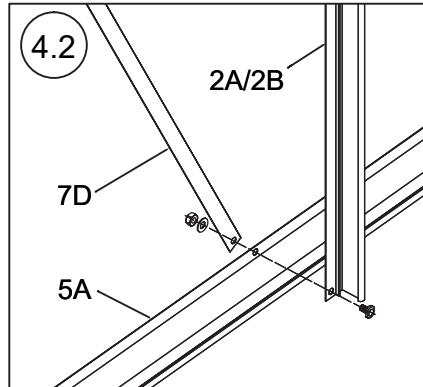
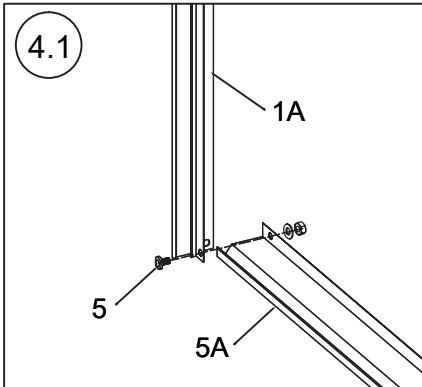
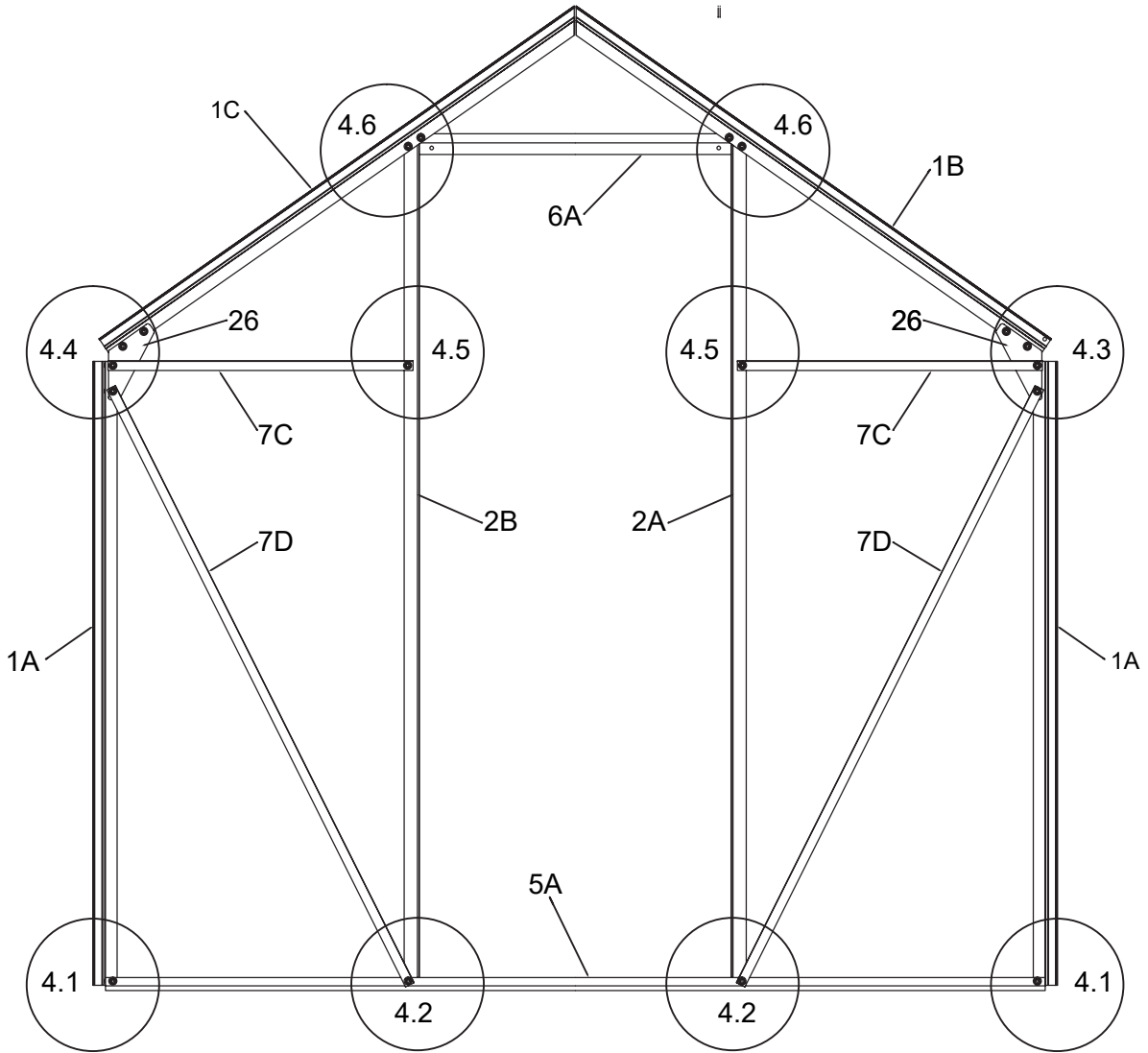

WSTAWIANIE DRZWI:

DOOR INSTALLATION:

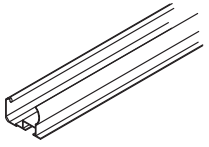
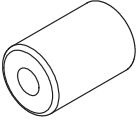
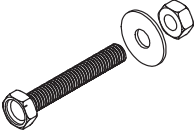
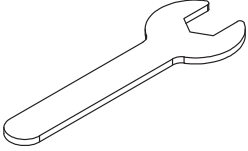
13A		1250	1X
2			1X
3		M6*40	1X
4			2X

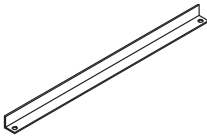
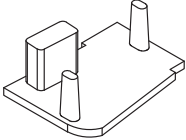
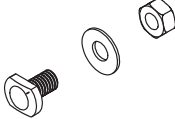
14A		380	1X
11			1X
5		M6*10	4X

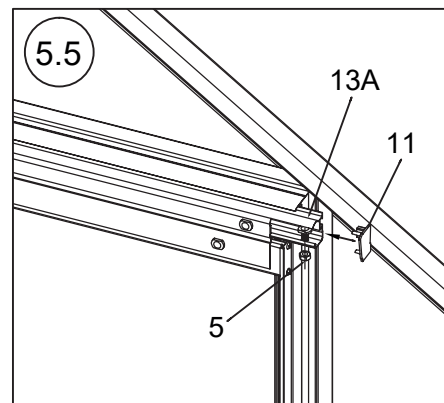
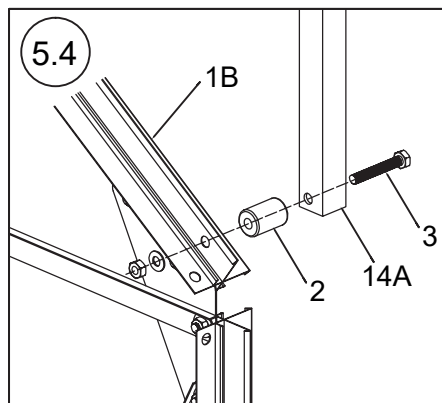
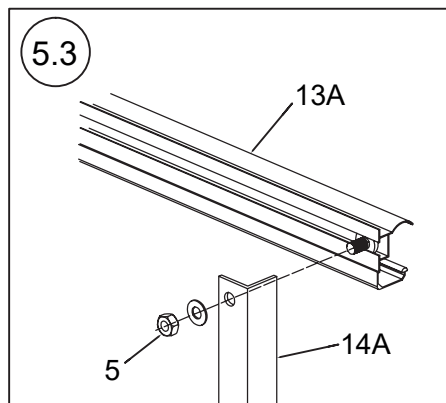
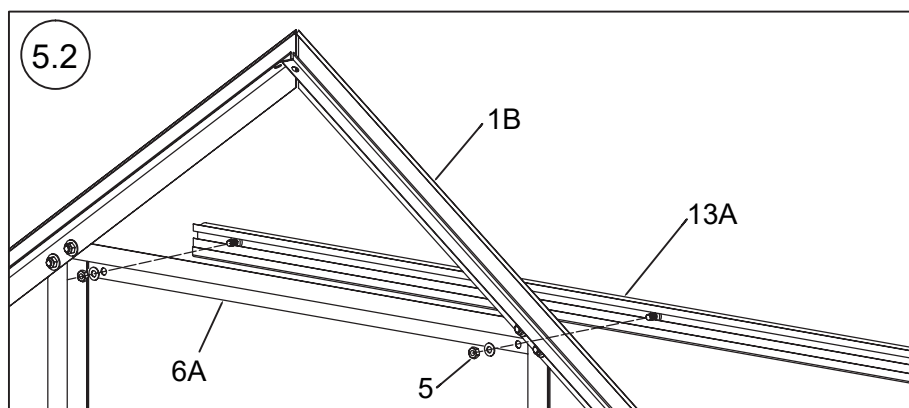
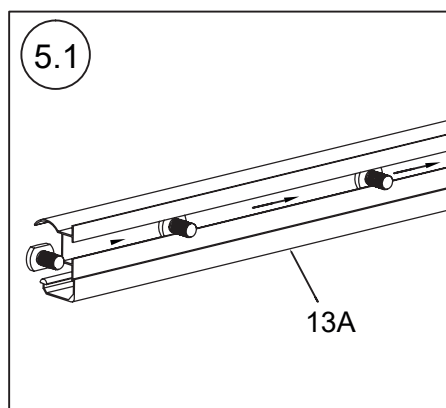
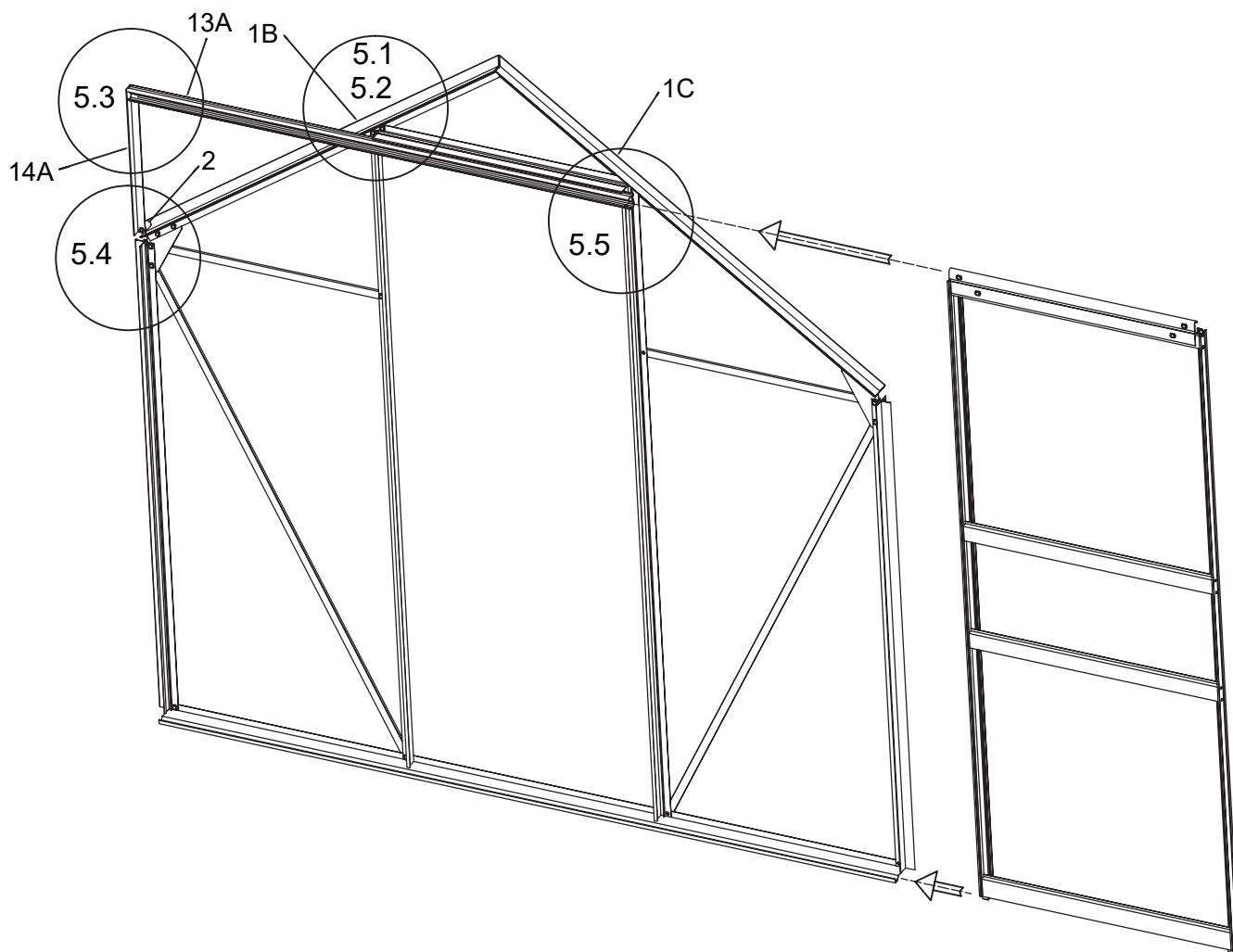
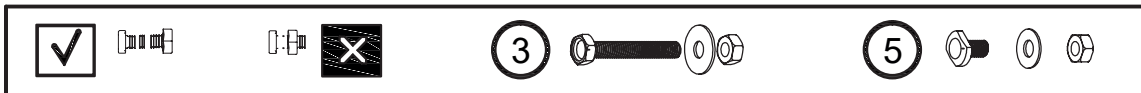

MONTAŻ ŚCIAN BOCZNYCH:

SIDE WALL ASSEMBLY:

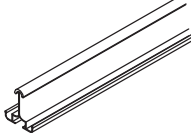
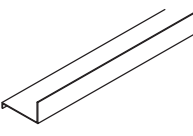
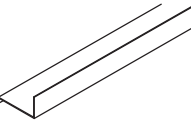
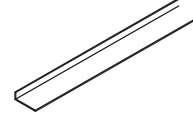
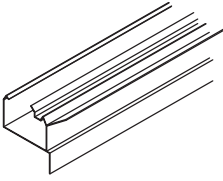
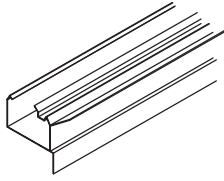
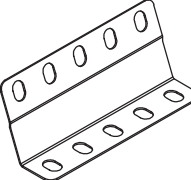
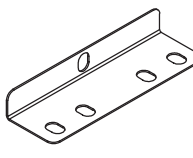
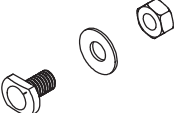
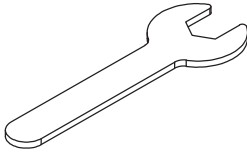
3C		1215	6X	4C		1220	2X
4D		1220	2X	7B		1300	4X
8B		1220	2X	8C		1220	2X
20			2X	22			2X
5		M6*10	62X	4			2X

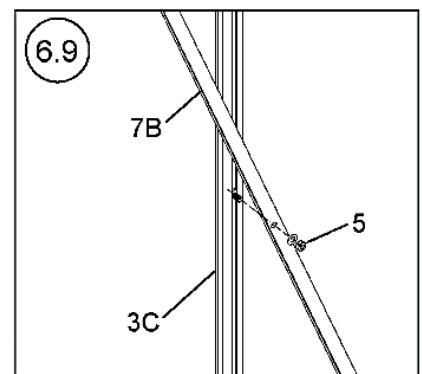
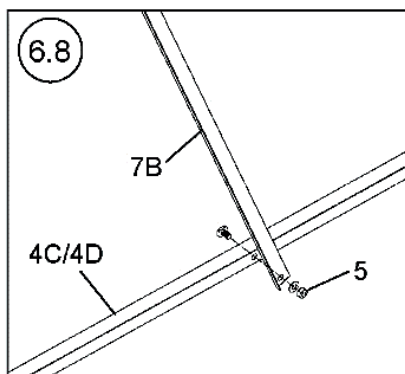
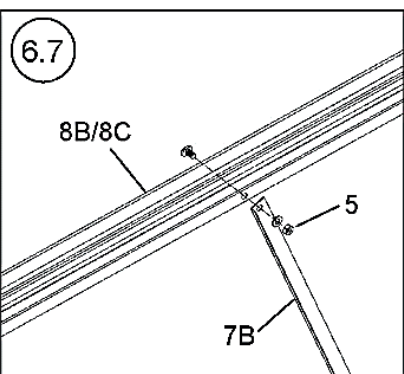
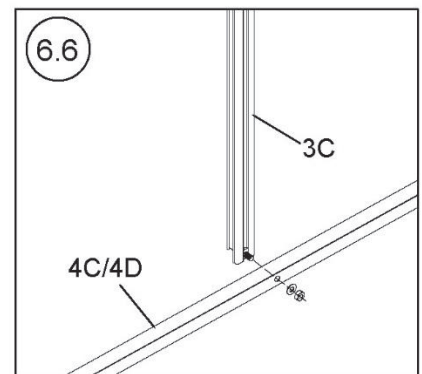
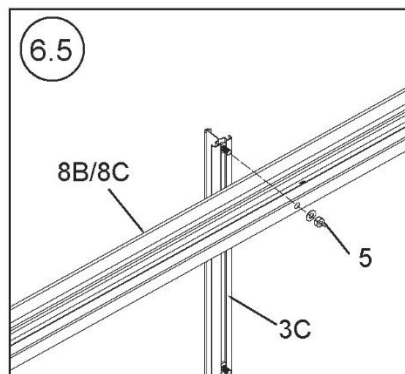
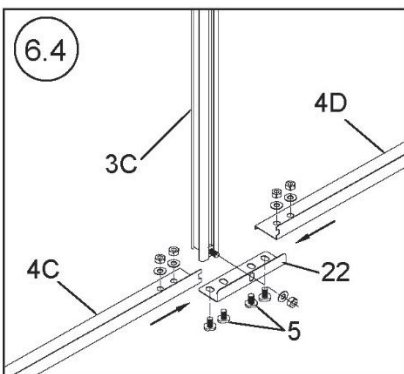
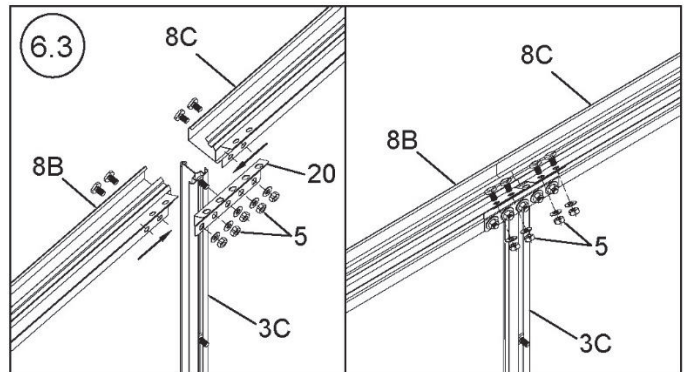
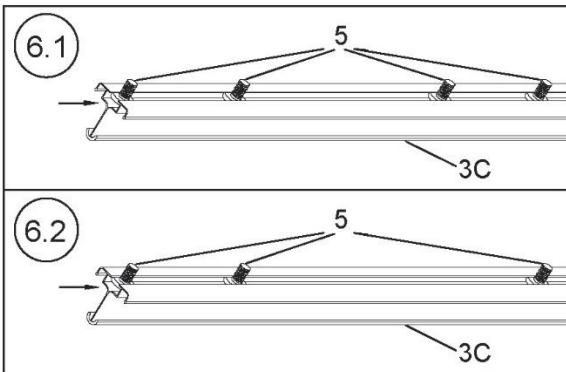
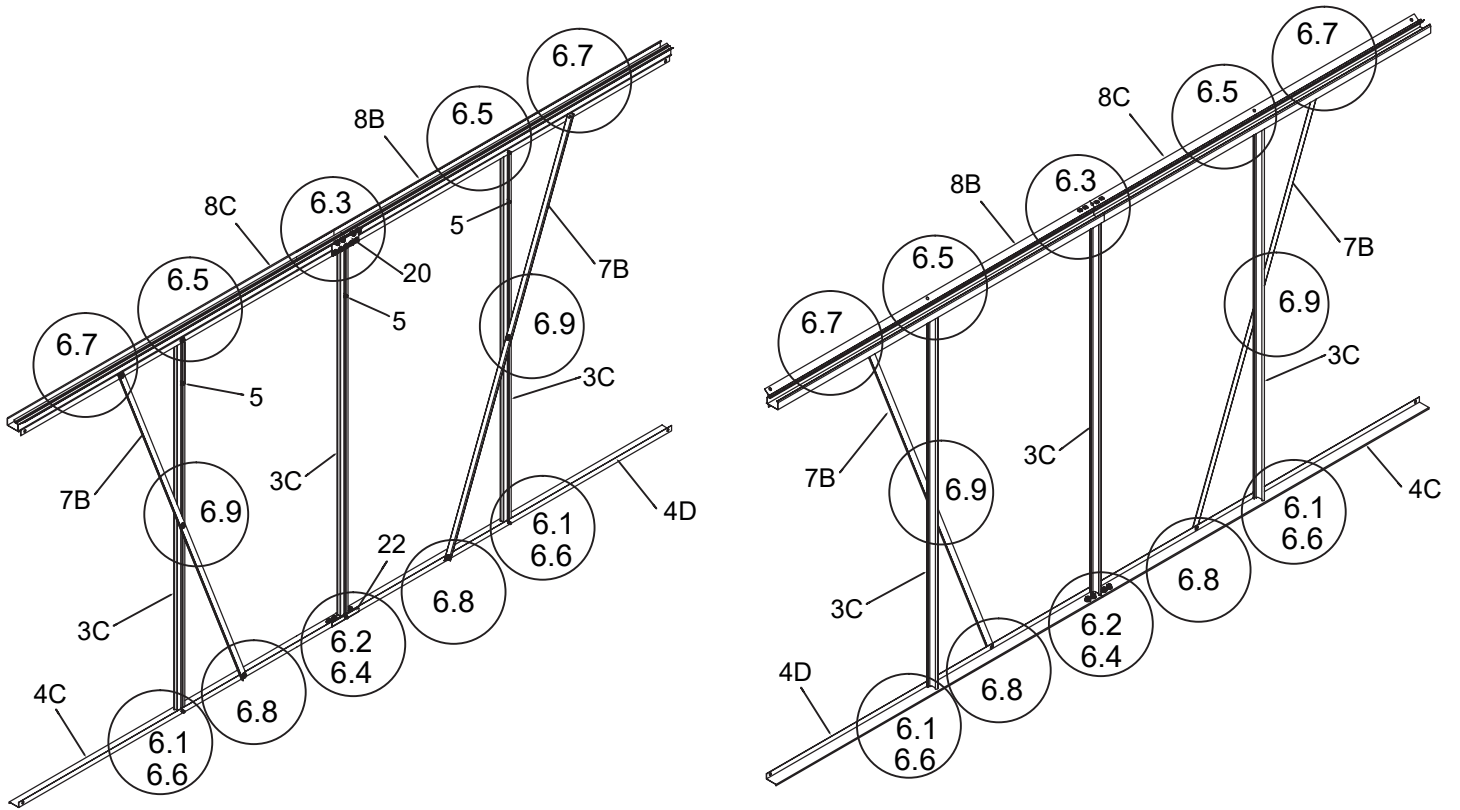

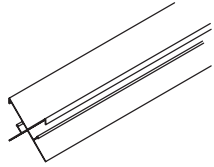
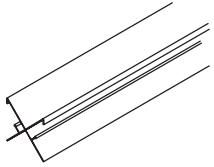
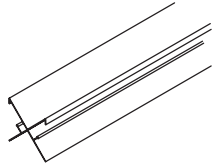
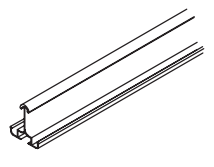
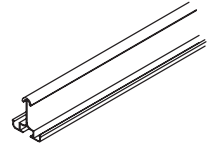
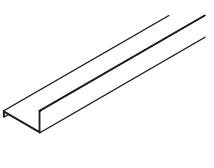
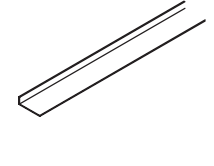
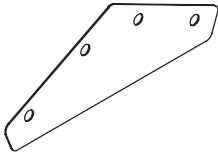
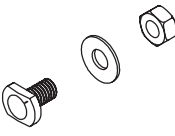
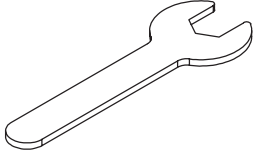
1A		1215	2X	1E		1130	1X
1D		1130	1X	3A		1665	1X
3B		1665	1X	4B		1830	1X
7A		1830	1X	26			2X
5		M6*10	16X	4			2X

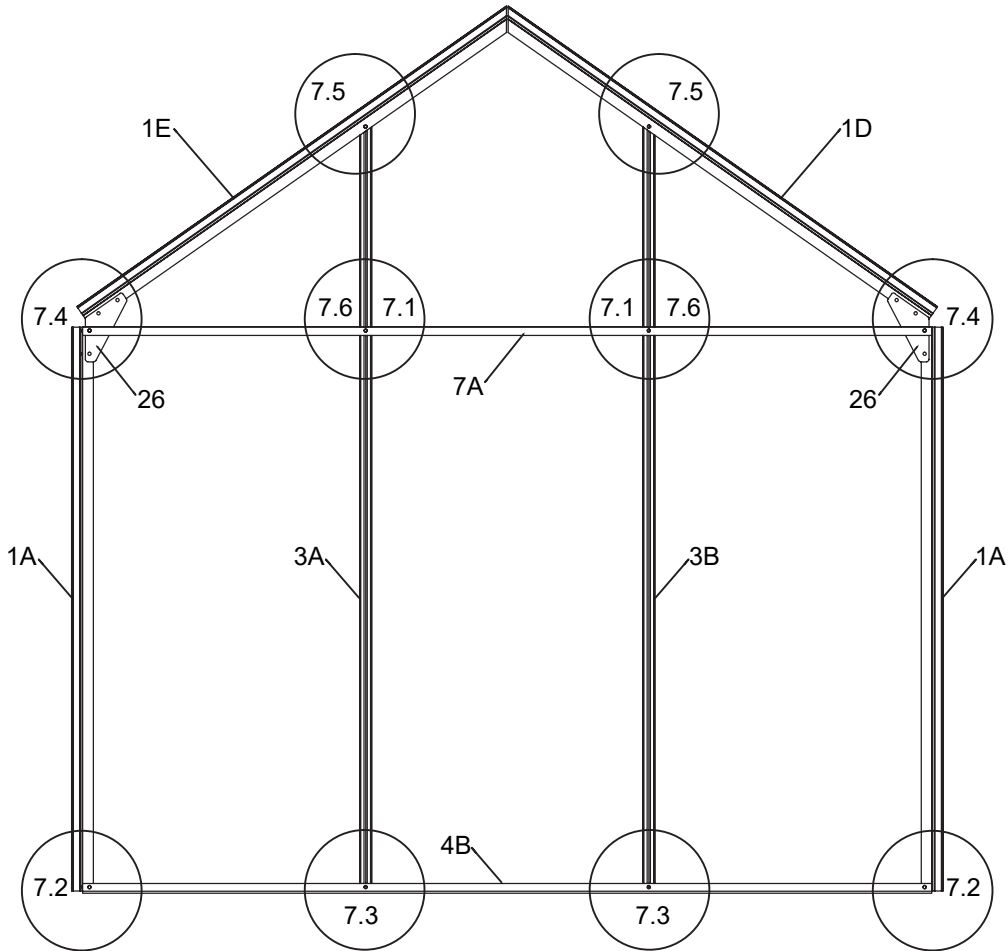

Zmontować ścianę tylną i odłożyć na bok do późniejszego wykorzystania.
Należy pamiętać, że na tym etapie nie trzeba montować poszczególnych płyt.

Assemble the back wall and put it aside for later use.
Note that the individual panels do not need to be assembled at this stage.

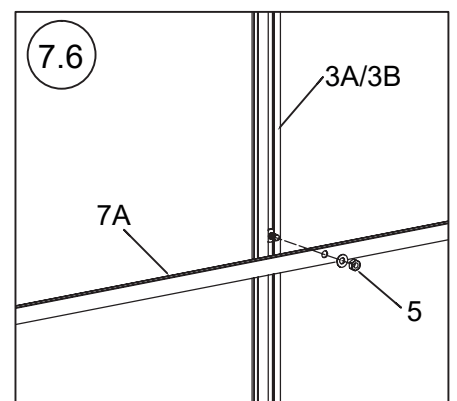
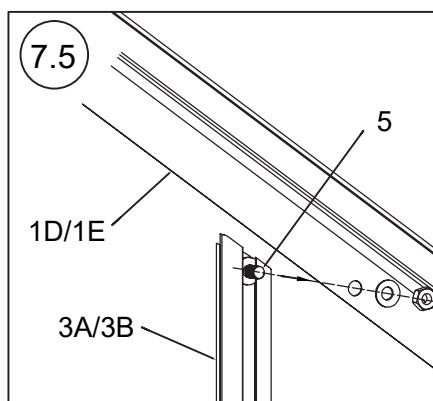
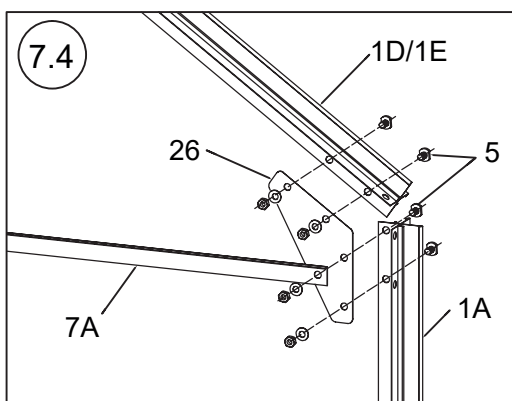
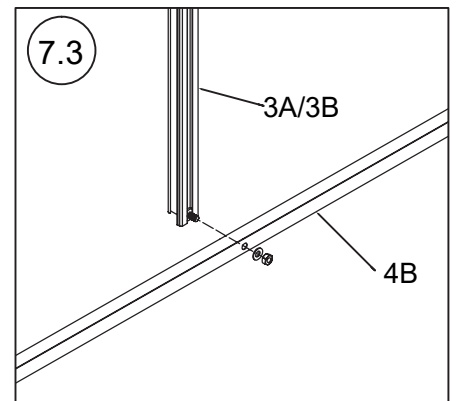
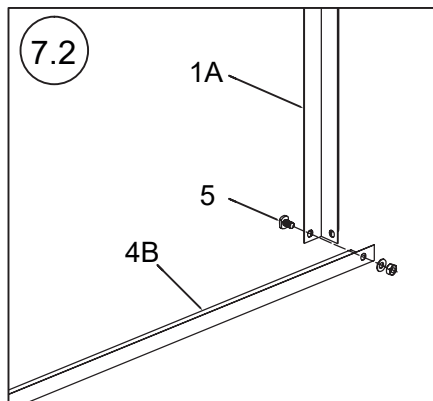
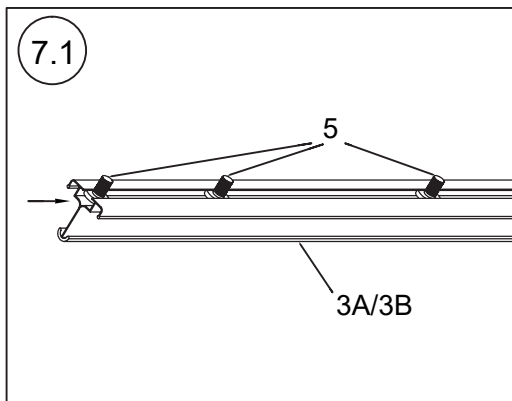

MONTAŻ KOŃCOWY STELAŻU - ETAP 1:

FINAL FRAME ASSEMBLY - STAGE 1:

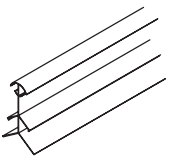
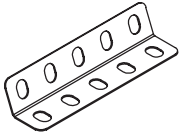
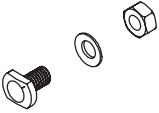
9B		1220	2X
21			1X
5		M6*10	12X

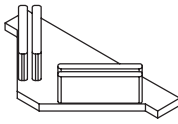
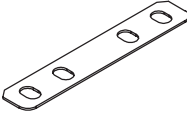
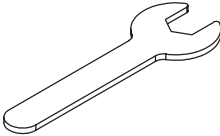
19			4X
23			2X
4			2X

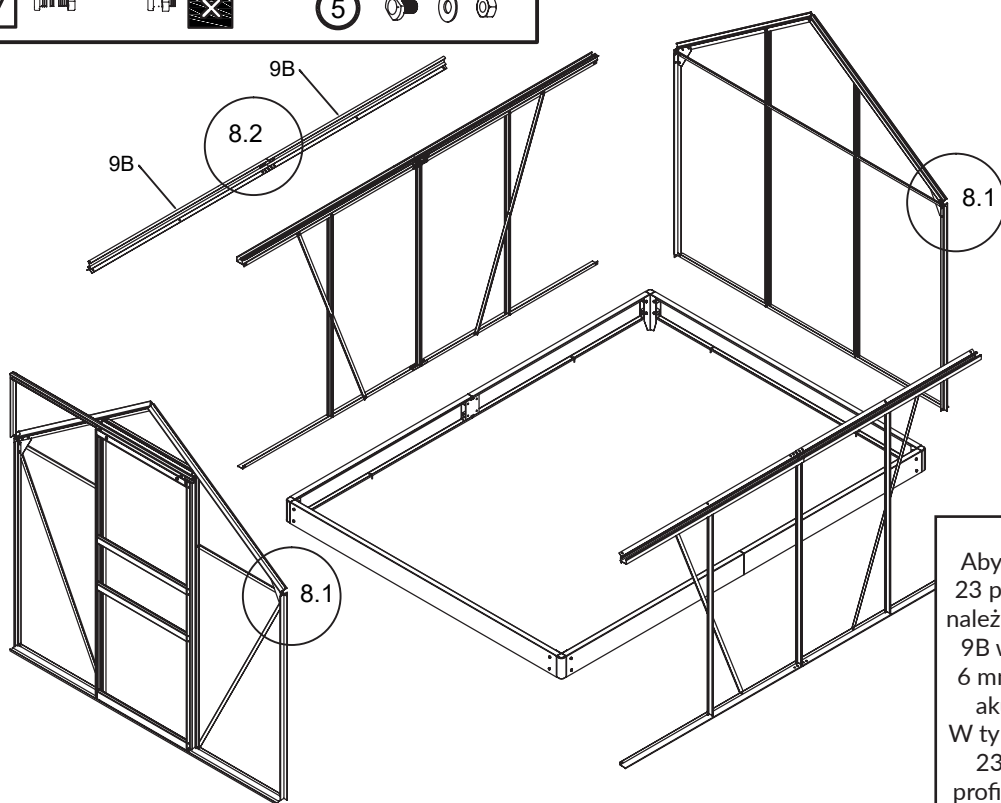
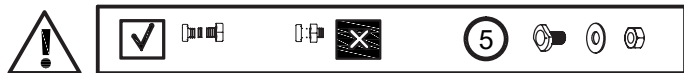

Aby zamocować płytki mocujące 23 przedstawione na rysunku 8.2, należy wcześniej w dwóch profilach 9B wykonać 4 otwory o średnicy 6 mm każdy za pomocą wkrętkarki akumulatorowej lub wiertarki. W tym celu ułożyć płytki mocujące 23 w przewidzianej pozycji na profilach 9B i zaznaczyć położenia otworów. Następnie wykonać otwory 6 mm. Zamocować płytki mocujące 23 na obydwu profilach 9B za pomocą śrub i nakrętek 5.

In order to fix the fixing plates 23 shown in Figure 8.2, 4 holes with a diameter of 6 mm each must first be drilled in the two profiles 9B using a cordless screwdriver or drill. To do this, place the fixing plates 23 in the intended position on the profiles 9B and mark the positions of the holes. Then make the 6 mm holes. Fasten the fixing plates 23 on both profiles 9B with screws and nuts 5.

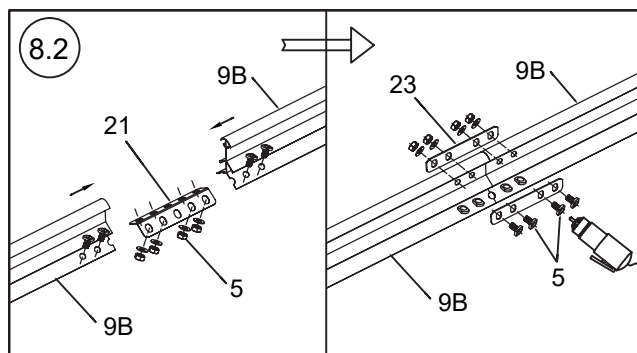
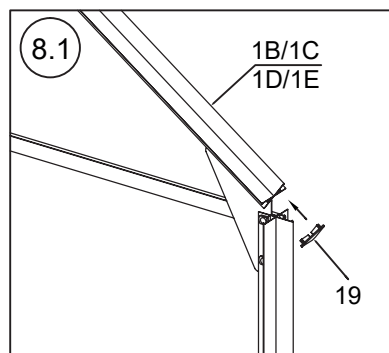

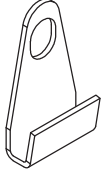
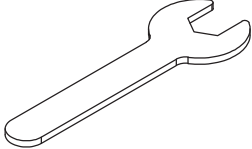
29		10X
4		2X

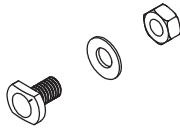
5		M6*10	16X
---	--	-------	-----

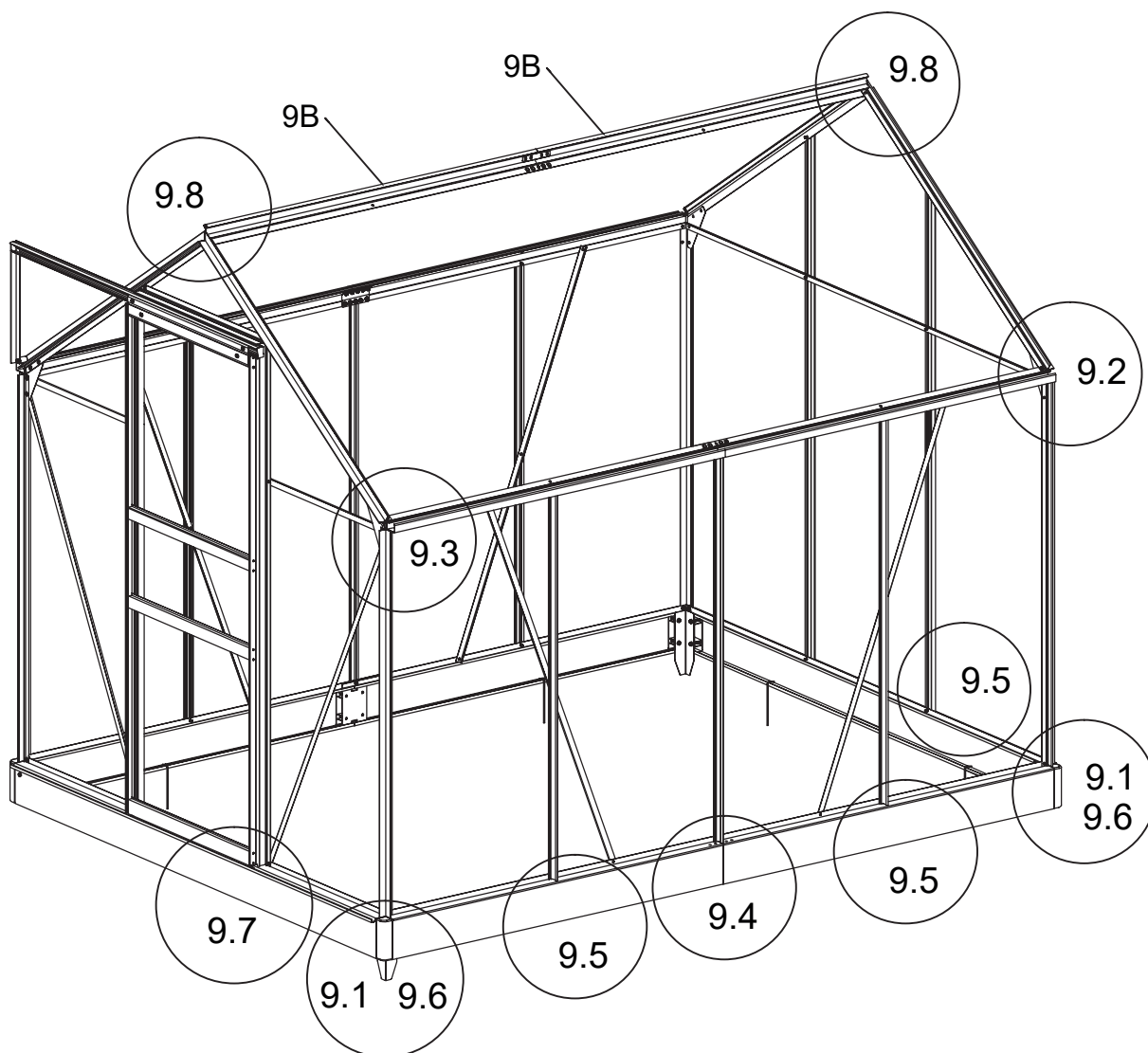
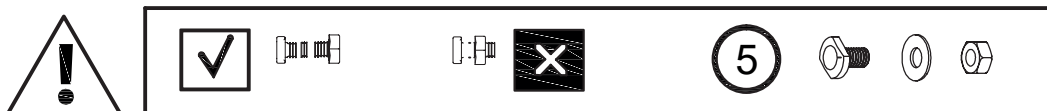

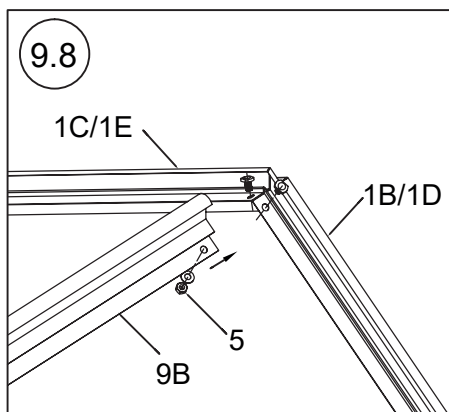
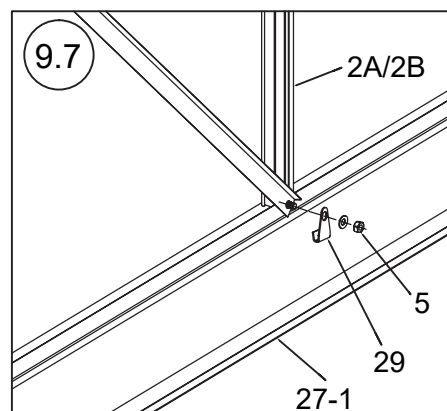
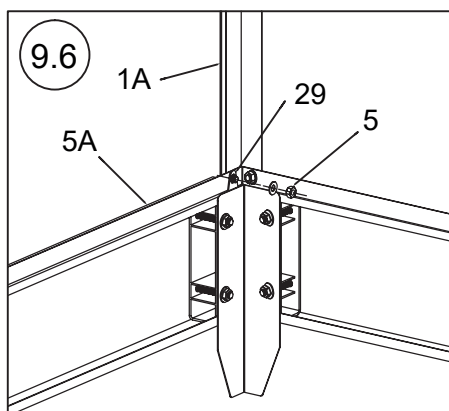
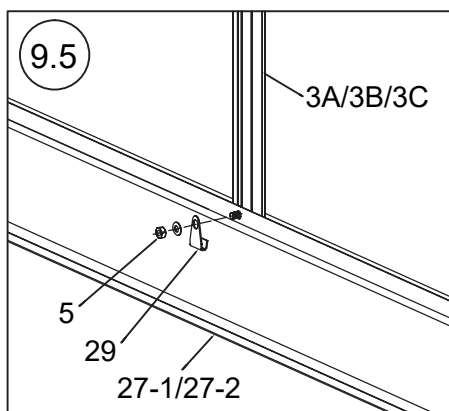
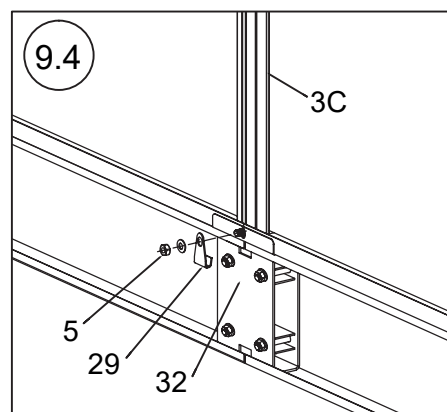
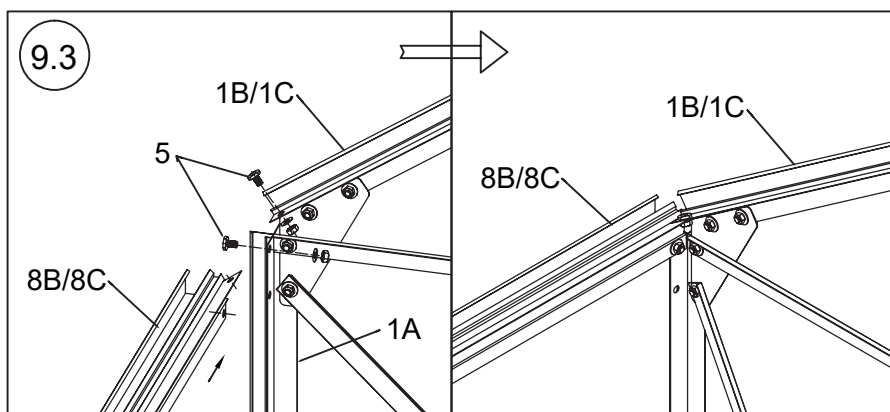
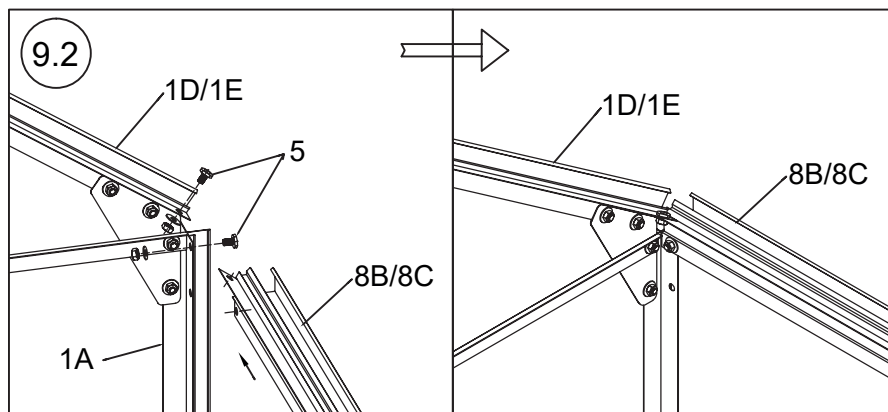
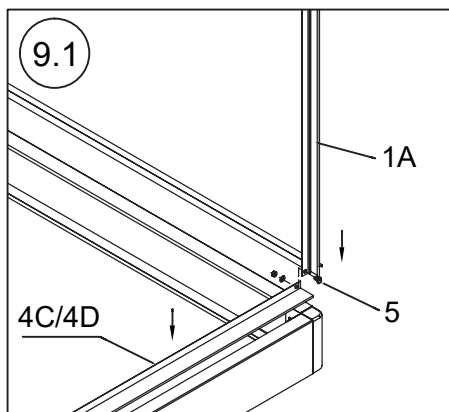

MONTAŻ PROFILI DACHOWYCH:

ROOF PROFILES ASSEMBLY:

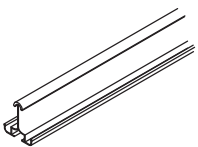
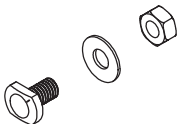

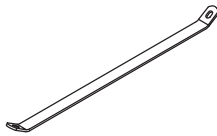
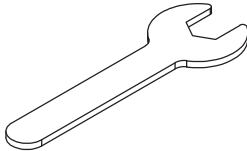
3D		1115	6X
5		M6*10	33X

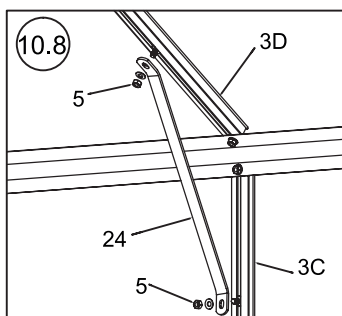
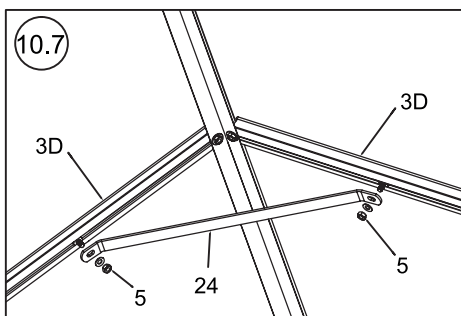
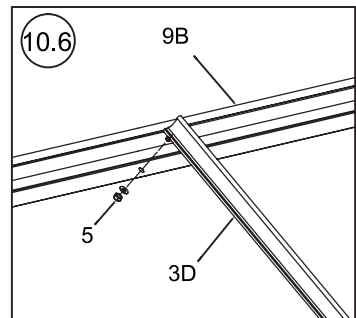
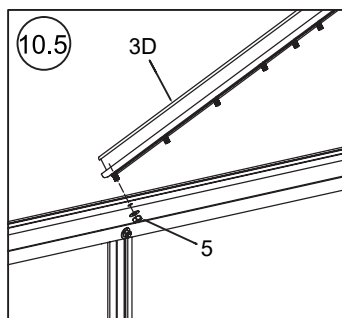
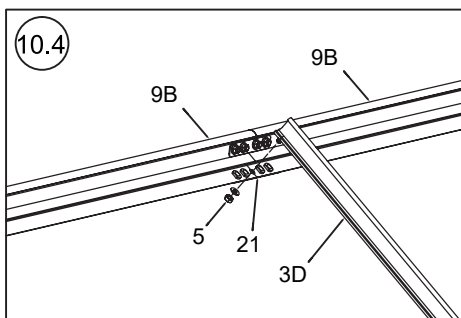
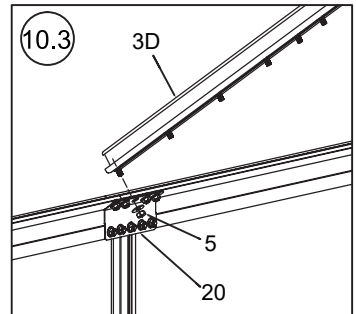
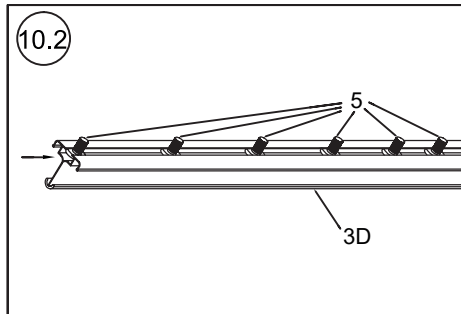
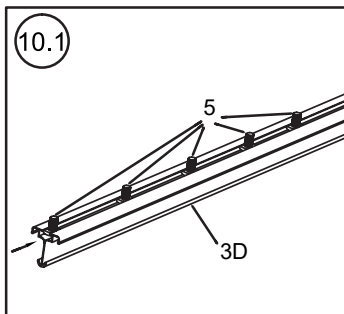
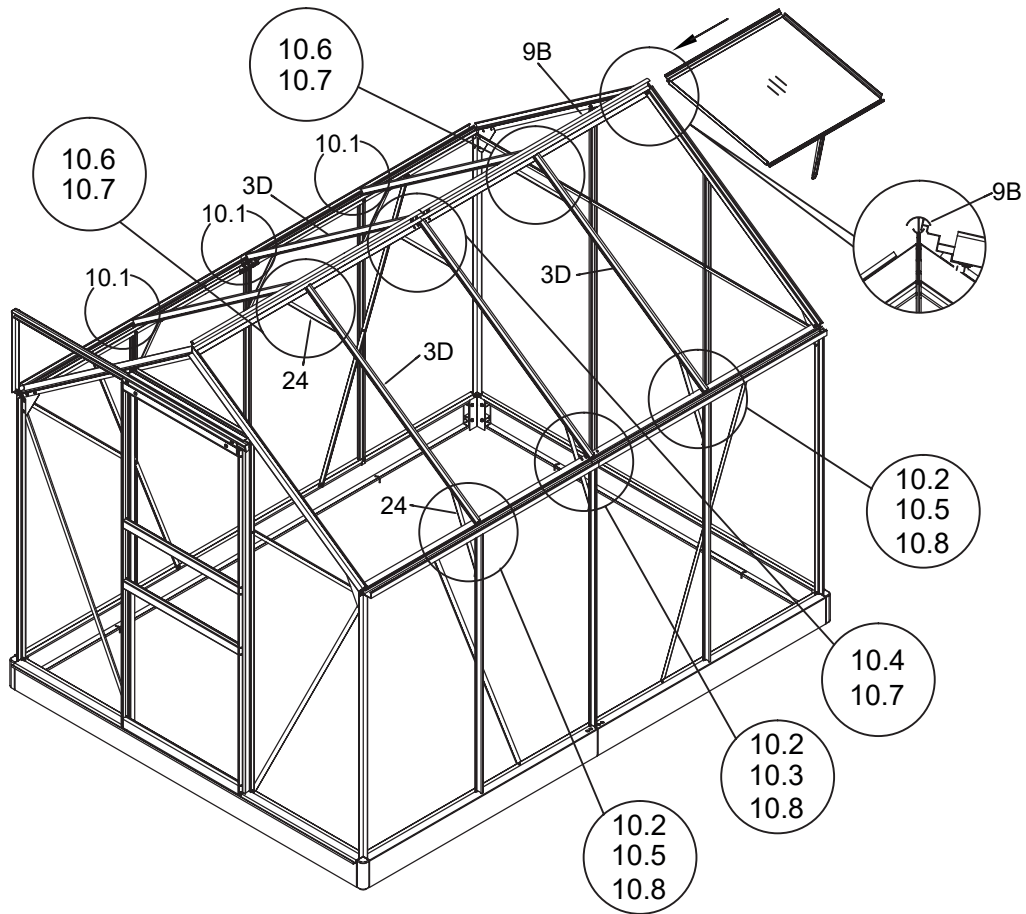
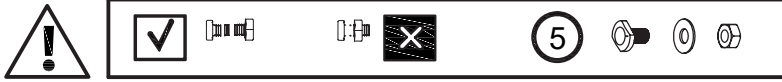
24			9X
4			1X



WSTAWIANIE OKIEN DACHOWYCH:

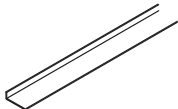

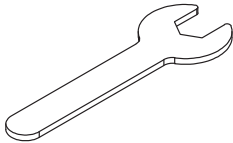

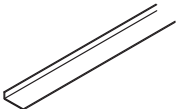
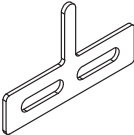
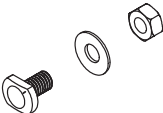
SKYLIGHT INSTALLATION:

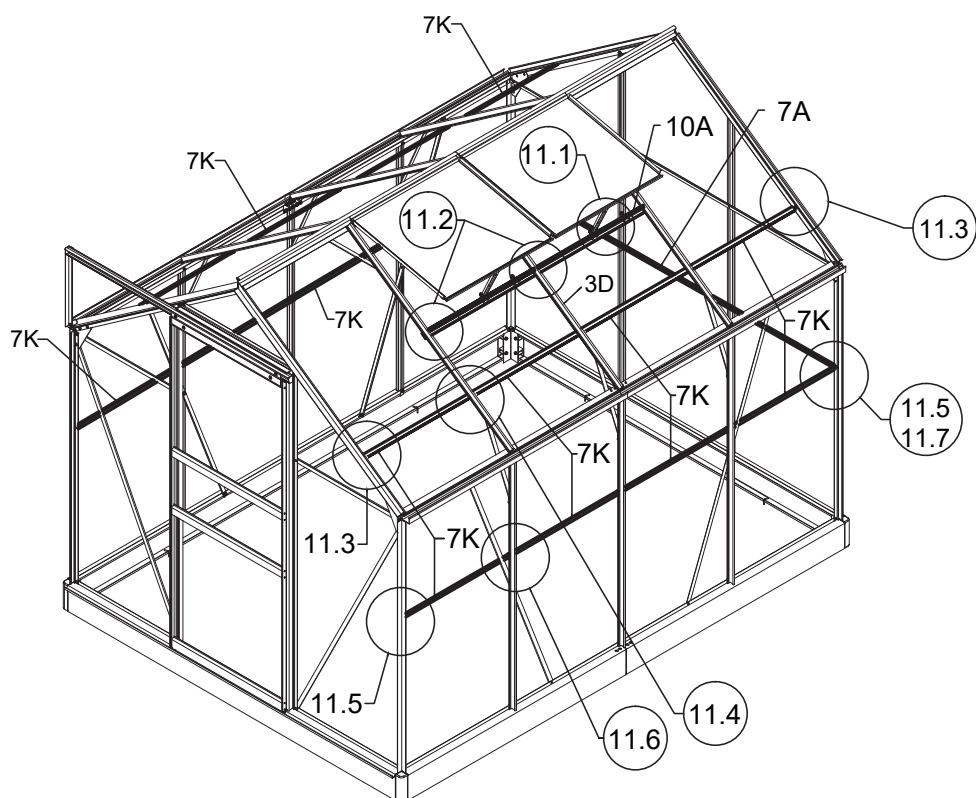
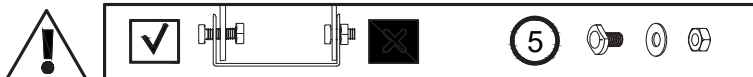

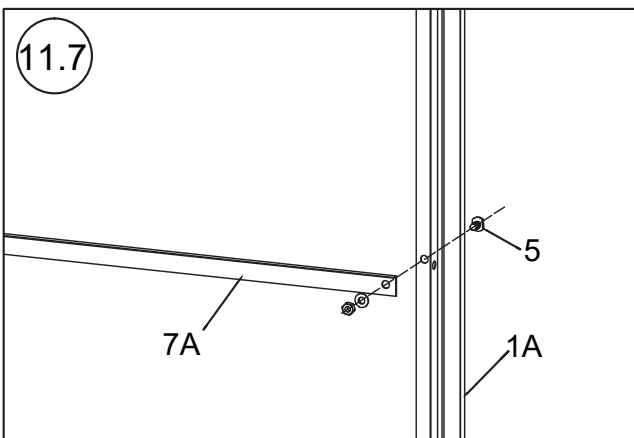
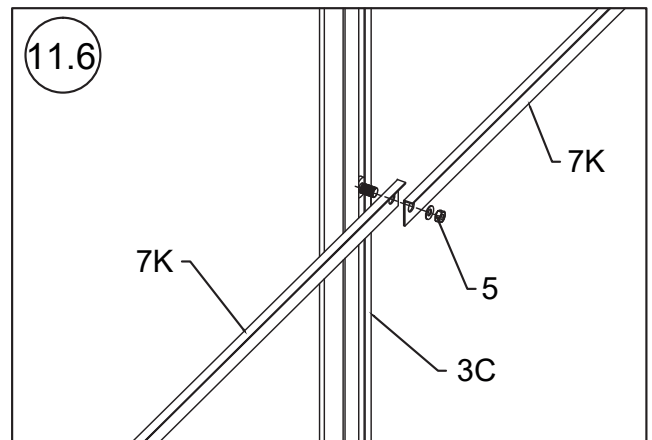
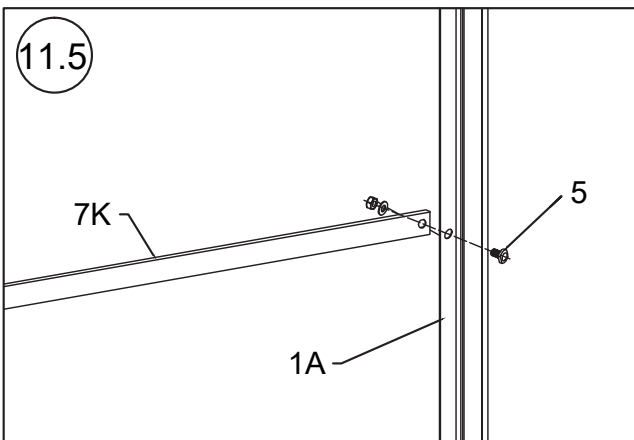
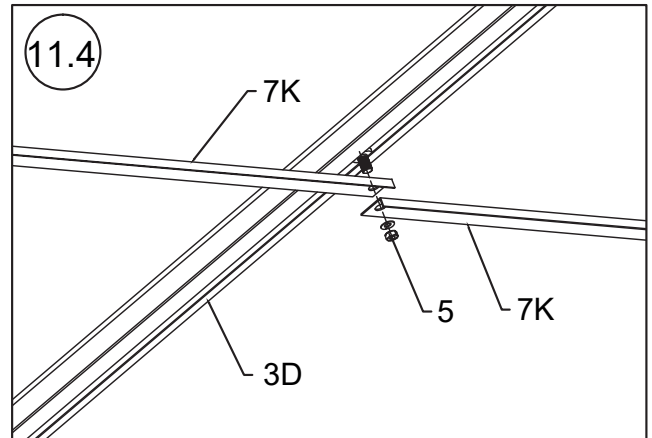
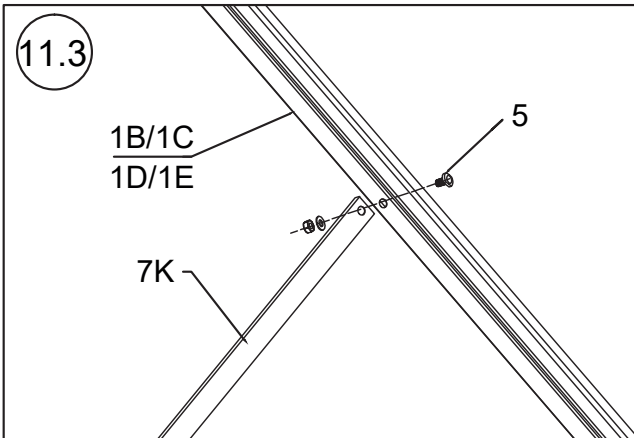
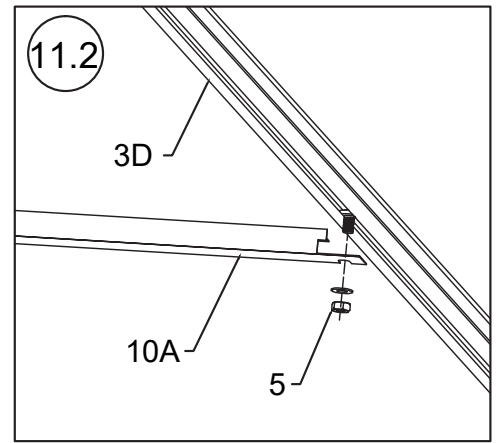
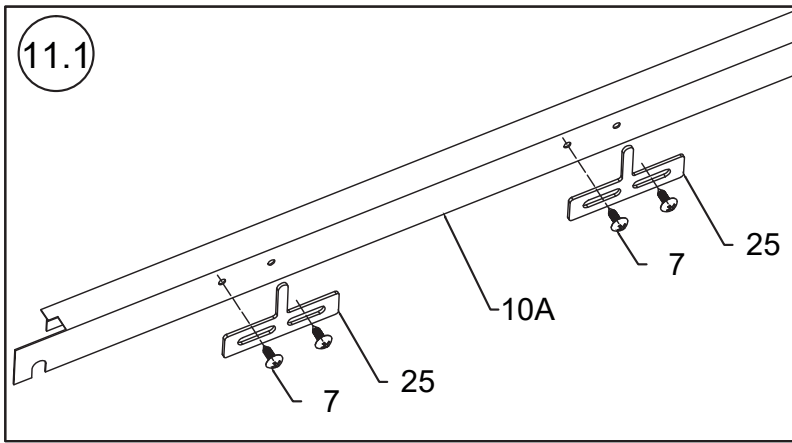
7A		1830	1X
10A		635	2X
7		M3*10	8X
4			1X

7K		625	16X
25			4X
5		M6*10	10X



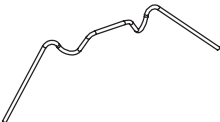
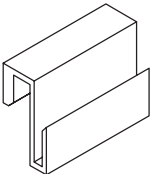

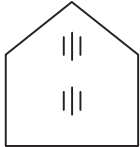
A4		603* 1210	13X
D4		603* 590	2X
G4		620* 240	1X
I4		620* 600	2X
14			200
17			64

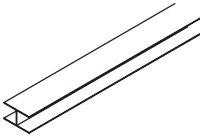
B4		603* 1120	6X
F4		603* 655	1X
H4		620* 230	1X
X4		603* 440	4X
21A		603	5X

⚠ Płyty ścienne mają obustronną ochronę UV! (Dotyczy to wszystkich płyt ściennych w przeciwieństwie do szkła). Oznacza to, że nie ma różnicy, po której stronie zostanie zamontowana płyta.

⚠ Przed montażem wystarczy zdjąć folię ochronną.

NA TYM ETAPIE NALEŻY SKORZYSTAĆ Z POMOCY DRABINY!

Zamocuj płyty ścienne za pomocą zacisków 14 i 17.

Mocowanie płyt ściennych za pomocą zacisków 14:

1. Umieść dwa końce zacisku w rowku ramy.
2. Umieść środkową część klipsa na płycie.

Dwie krawędzie klipsa znajdują się pod brzegiem płyty, a środkowa krawędź utrzymuje płytę w miejscu.

⚠ The wall panels have UV protection on both sides! (This applies to all wall panels in contrast to glass). It makes no difference on which side the plate is installed..

⚠ Simply remove the protective film before installation.

USE A LADDER AT THIS STAGE!

Fasten the wall plates with clamps 14 and 17

Fastening wall panels with clamps 14:

1. Place the two ends of the clamp in the groove of the frame.
2. Place the middle part of the clip on the plate.

The two edges of the clip are under the edge of the plate and the middle edge holds the plate in place.



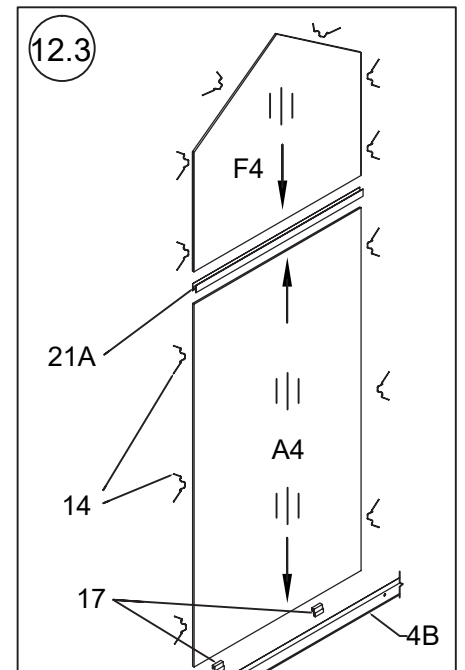
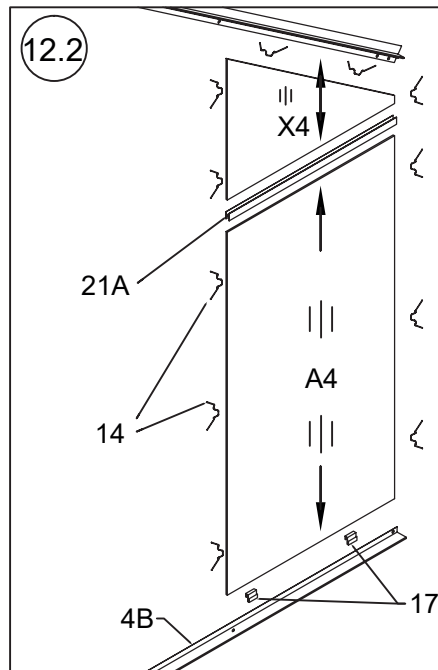
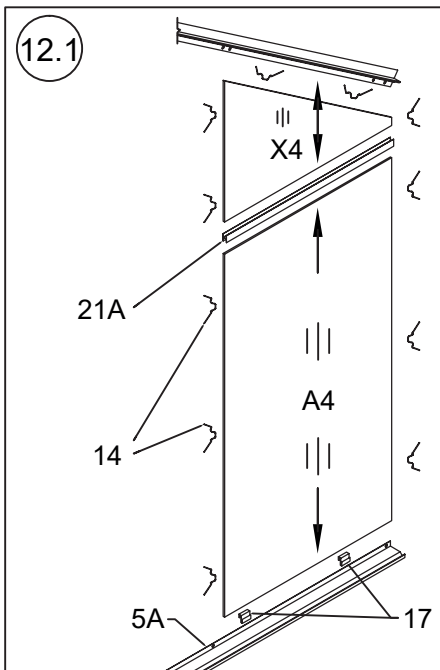
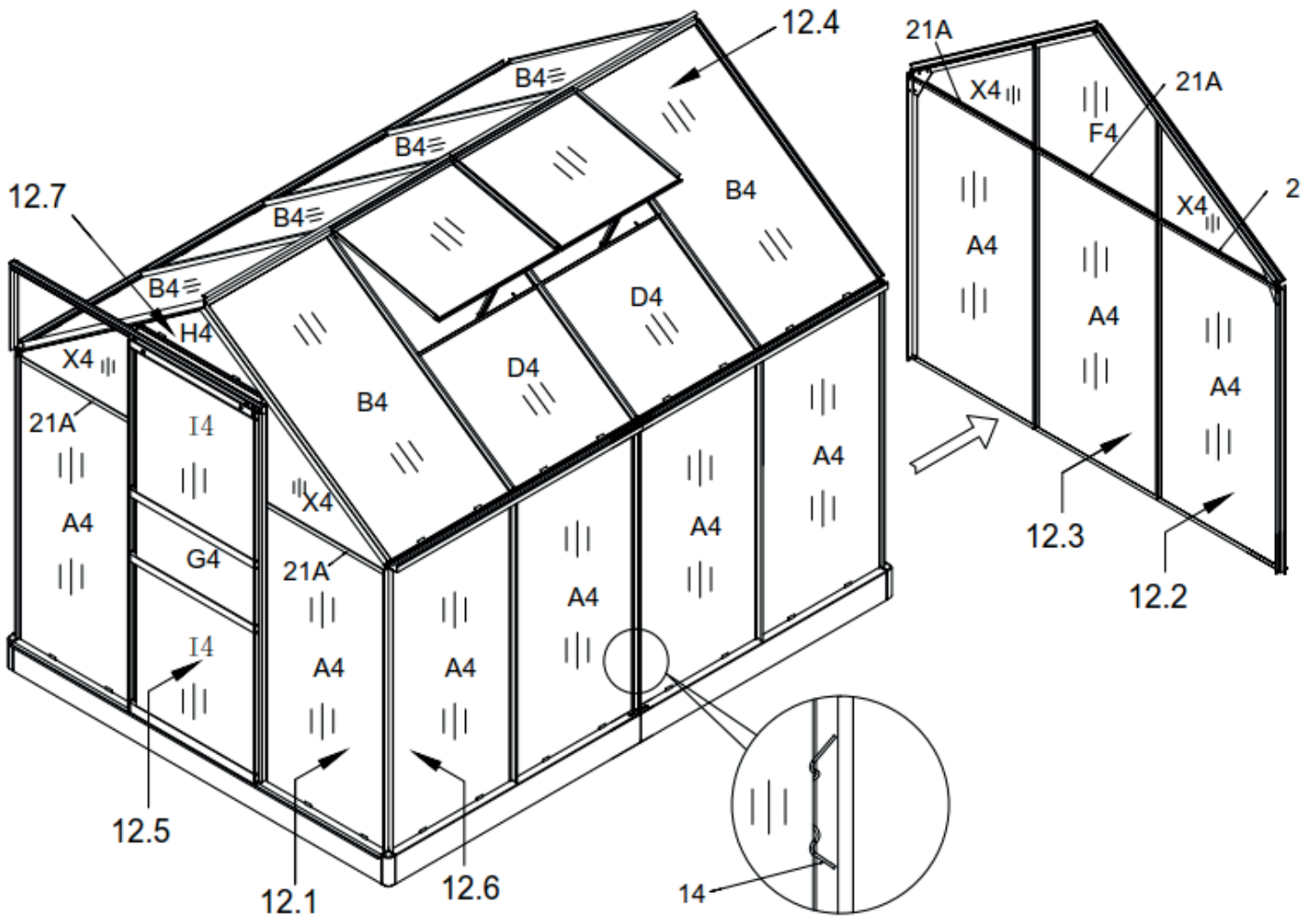

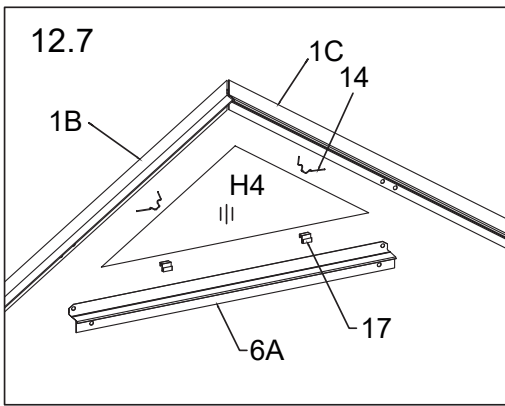
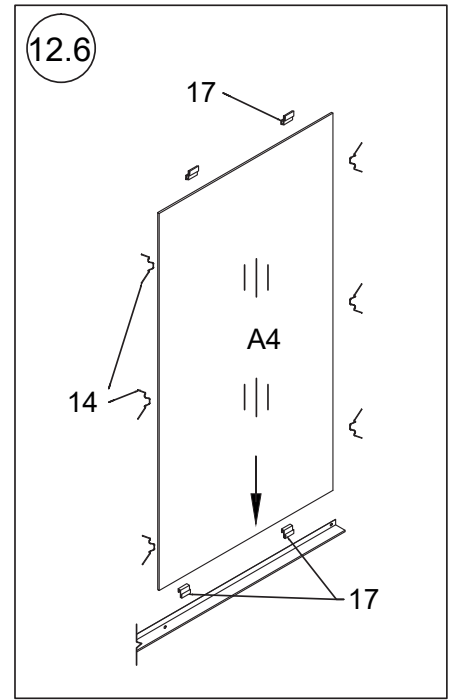
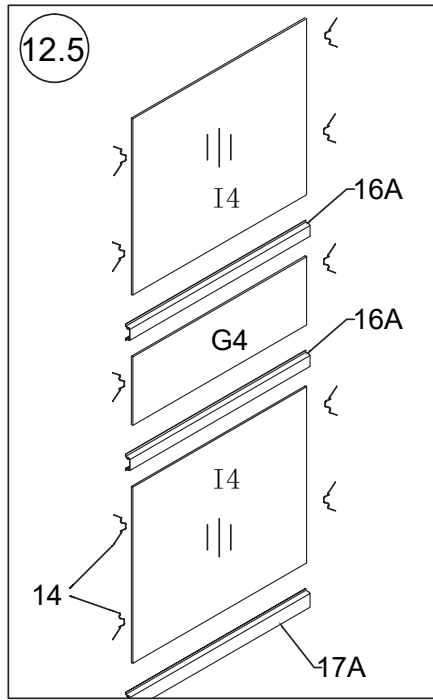
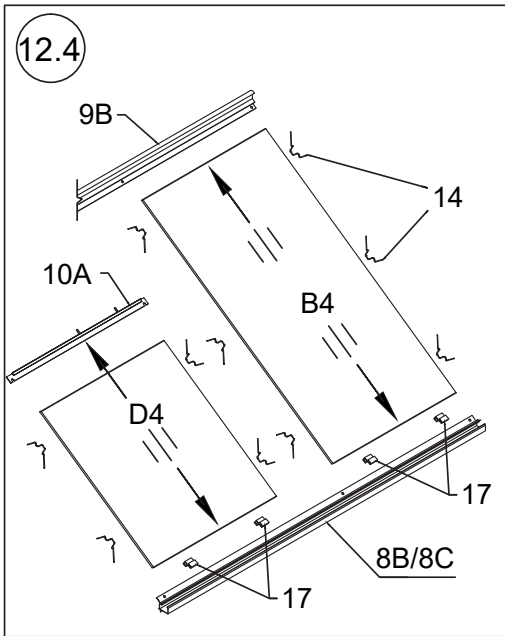

MOCOWANIE RYNNY:

GUTTER INSTALLATION:

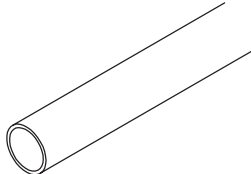
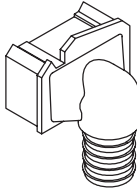
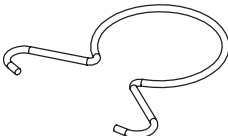
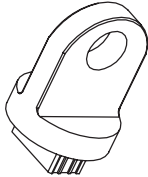
8		4X
10		2X
16		8X
33		6X

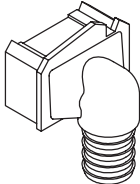
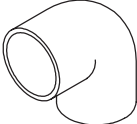
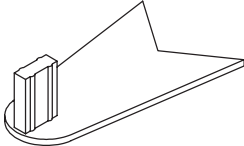
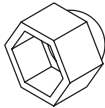
9		2X
15		4X
18		2X
35		202

