

PL EN

## DOMEK NARZĘDZIOWY

Instrukcja montażu i obsługi

## STEEL TOOL SHED

Instruction Manual

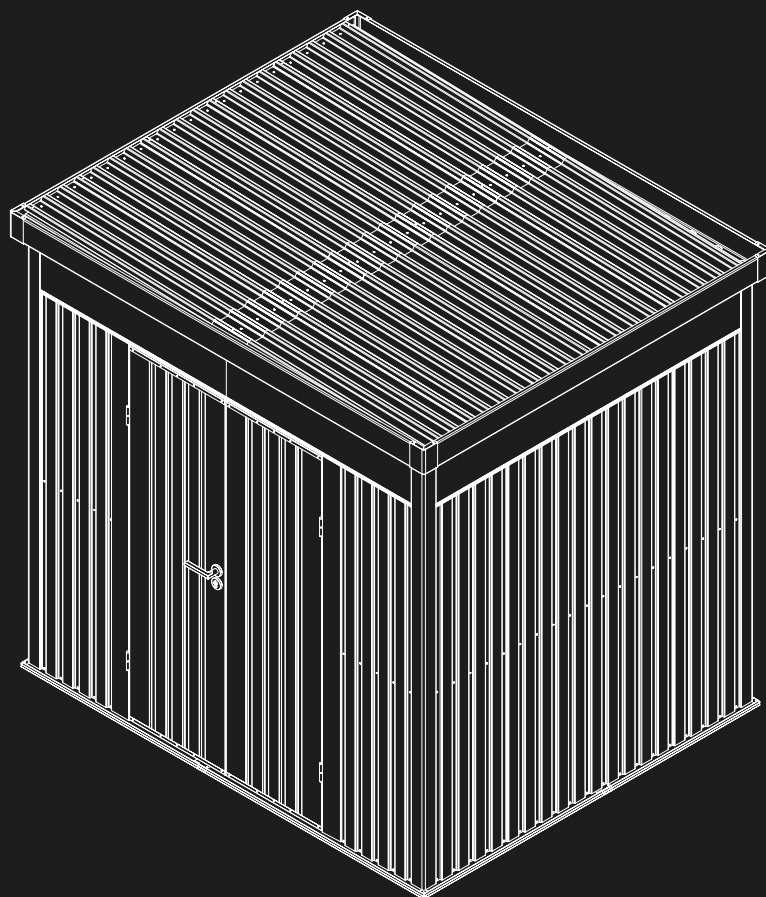

# MIR1008PC

## DOMEK NARZĘDZIOWY

**Producent**

Mirpol sp. z o.o.

ul. Ciasna 3, 35-232 Rzeszów

e-mail: [biuro@mirpol.rzeszow.pl](mailto:biuro@mirpol.rzeszow.pl)

[www.mirpol.rzeszow.pl](http://www.mirpol.rzeszow.pl)

**Made in China**

mirpol



**UWAGA!** Przeczytaj uważnie instrukcje obsługi przed montażem. Prosimy o ścisłe przestrzeganie instrukcji. Prosimy dokładnie sprawdzić, czy wszystkie części zawartości opakowania są nienaruszone. Aby uniknąć obrażeń rękawice robocze są zalecane podczas montażu.

## ZANIM ROZPOCZNIESZ MONTAŻ

### Instrukcja obsługi

Przed rozpoczęciem montażu, sprawdź lokalne przepisy budowlane dotyczące fundamentów, lokalizacji i innych wymagań. Przestuduj i zrozum ten podręcznik montażu. Ważne informacje i pomocne wskazówki sprawią, że twoja praca stanie się łatwiejsza i przyjemniejsza.

### Instrukcje składania

Wskazówki zawarte w tej instrukcji zawierają wszystkie odpowiednie informacje dla twojego modelu. Przeczytaj całą instrukcję przed rozpoczęciem, a podczas montażu dokładnie wykonaj sekwencje kroków, aby uzyskać właściwy wynik.

### Lista części

Sprawdź, czy masz wszystkie niezbędne części do budowy. Rozdziel zawartość kartonu po numerach części podczas przeglądania listy części. Pierwsze kilka kroków pokazuje, jak połączyć powiązane części, aby utworzyć większe podzespoły, które będą później używane. Zapoznaj się ze sprzętem i łącznikami, aby ułatwić korzystanie z nich podczas montażu. Są one pakowane w karton. Zwróć uwagę, że dodatkowe elementy zostały dostarczone dla Twojej wygody.

## PLANUJ NAPRZÓD

### Obserwuj pogodę

Upewnij się, że w dzień, w którym chcesz zainstalować swój domek, jest sucho. Nie próbuj montować domku w wietrzny dzień.

### Praca zespołowa













Gdy tylko jest to możliwe, dwie lub więcej osób powinno współpracować, aby złożyć domek. Jedna osoba może pozycjonować części lub panele, podczas gdy druga jest w stanie poradzić sobie z zapięciami i narzędziami.



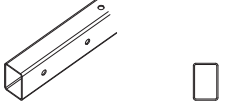
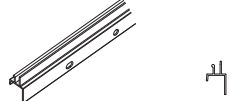
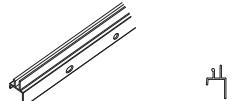

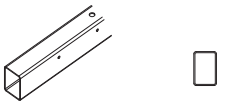

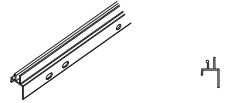
### Narzędzia i materiały

Tylko podstawowe narzędzia i materiały są potrzebne do budowy twojego domku. Wybierz metodę kotwiczenia i rodzaj podłoża, którego chcesz użyć w celu utworzenia pełnej listy potrzebnych materiałów.

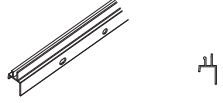
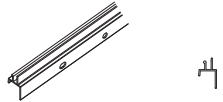



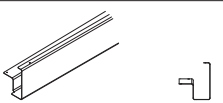
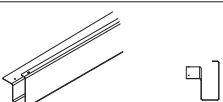
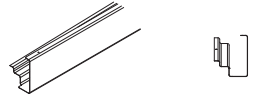

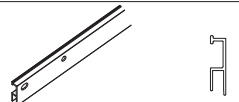
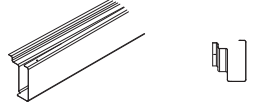
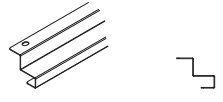
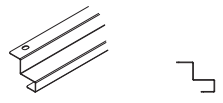
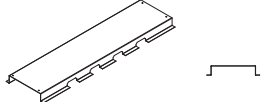



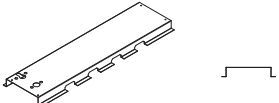

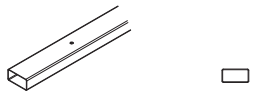
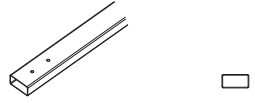
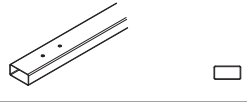
# LISTA CZĘŚCI

| NUMER | RYSUNEK   | ILOŚĆ |
|-------|---|-------|
| 1     |    | 2     |
| 2     |    | 2     |
| 3L    |    | 1     |
| 3R    |    | 1     |
| 4A    |    | 4     |
| 4L    |    | 1     |
| 4R    |   | 1     |
| 7     |  | 1     |
| 7A    |  | 1     |
| 7B    |  | 1     |
| 8     |  | 1     |
| 9     |  | 2     |
| 10    |  | 4     |
| 10A   |  | 1     |
| 10B   |  | 1     |

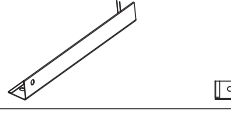
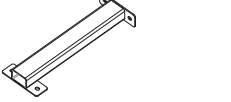
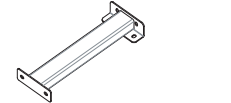
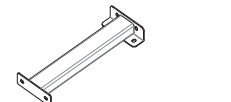
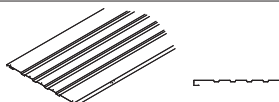
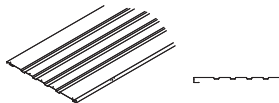
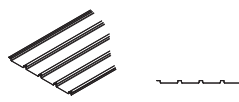

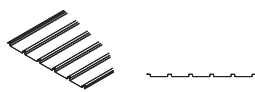
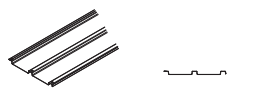

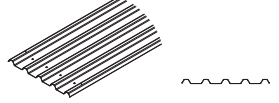
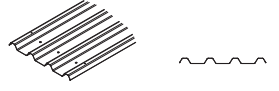
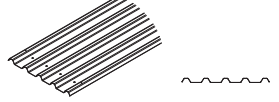
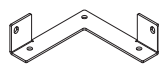
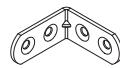
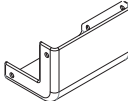
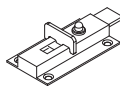
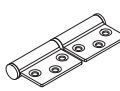

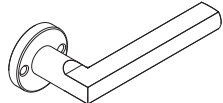
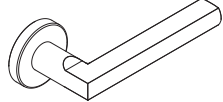

| NUMER | RYSUNEK   | ILOŚĆ |
|-------|---|-------|
| 11A   |    | 2     |
| 11B   |    | 2     |
| 12    |    | 2     |
| 13    |    | 1     |
| 15A   |    | 2     |
| 15B   |    | 2     |
| 15L   |   | 1     |
| 15R   |  | 1     |
| 17    |  | 1     |
| 17A   |  | 2     |
| 17B   |  | 2     |
| 18    |  | 1     |
| 20    |  | 2     |
| 20D   |  | 1     |
| 20L   |  | 1     |

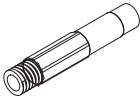
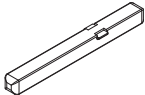
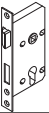
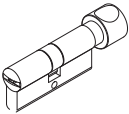
# LISTA CZĘŚCI

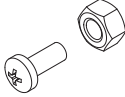

| NUMER | RYSUNEK   | ILOŚĆ |
|-------|---|-------|
| 20R   |    | 1     |
| 20U   |    | 1     |
| 21L   |    | 1     |
| 21R   |    | 1     |
| 22    |    | 2     |
| 24    |    | 1     |
| 25L   |  | 1     |
| 25R   |  | 1     |
| B1    |  | 4     |
| B2    |  | 8     |
| B3    |  | 1     |
| B4    |  | 1     |
| DLA   |  | 1     |
| DRA   |  | 1     |
| P2A   |  | 6     |

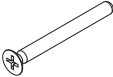
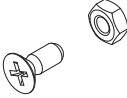
| NUMER | RYSUNEK   | ILOŚĆ |
|-------|---|-------|
| P3    |    | 8     |
| P4A   |    | 1     |
| P5    |    | 1     |
| P6    |    | 4     |
| P7    |    | 1     |
| P8    |    | 4     |
| JM5   |  | 4     |
| JM6   |  | 8     |
| GC    |  | 4     |
| DC    |  | 2     |
| DH    |  | 4     |
| S04   |  | 1     |
| S05   |  | 1     |
| S06   |  | 1     |
| S07   |  | 1     |



# LISTA CZĘŚCI

| NUMER | RYSUNEK   | ILOŚĆ |
|-------|---|-------|
| S13   |    | 1     |
| S14   |    | 1     |
| ST    |    | 1     |
| SX    |    | 1     |
| F1    |    | 471   |
| S1    |    | 300   |
| S2    |  | 266   |
| F2    |  | 8     |
| F3    |  | 12    |
| M4X30 |  | 4     |
| M4X40 |  | 1     |
| M4X10 |  | 2     |
| F6    |  | 32    |
| 6*80  |  | 8     |

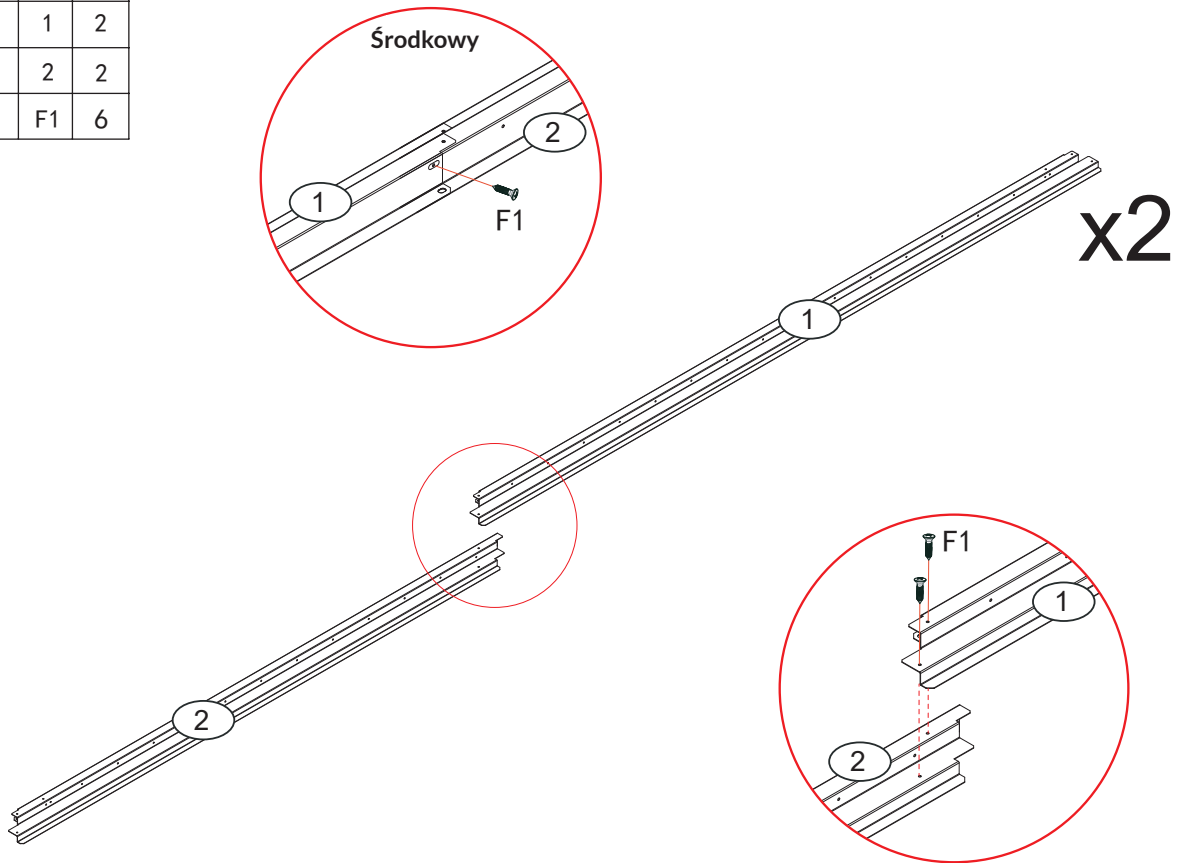

# MONTAŻ

| Części  | Nr | Ilość |
|---|----|-------|
|  | 1  | 2     |
|  | 2  | 2     |
|  | F1 | 6     |

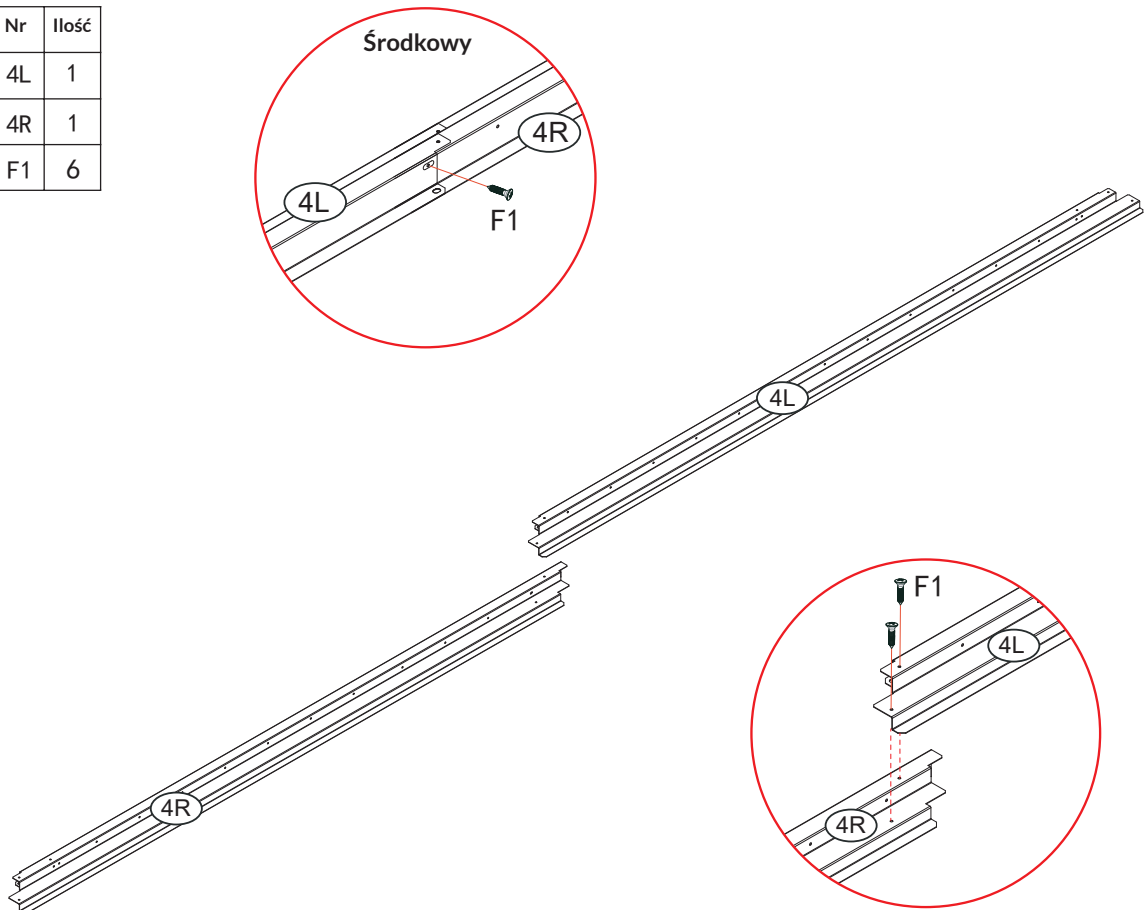

| Części  | Nr | Ilość |
|---|----|-------|
|  | 4L | 1     |
|  | 4R | 1     |
|  | F1 | 6     |



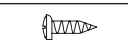

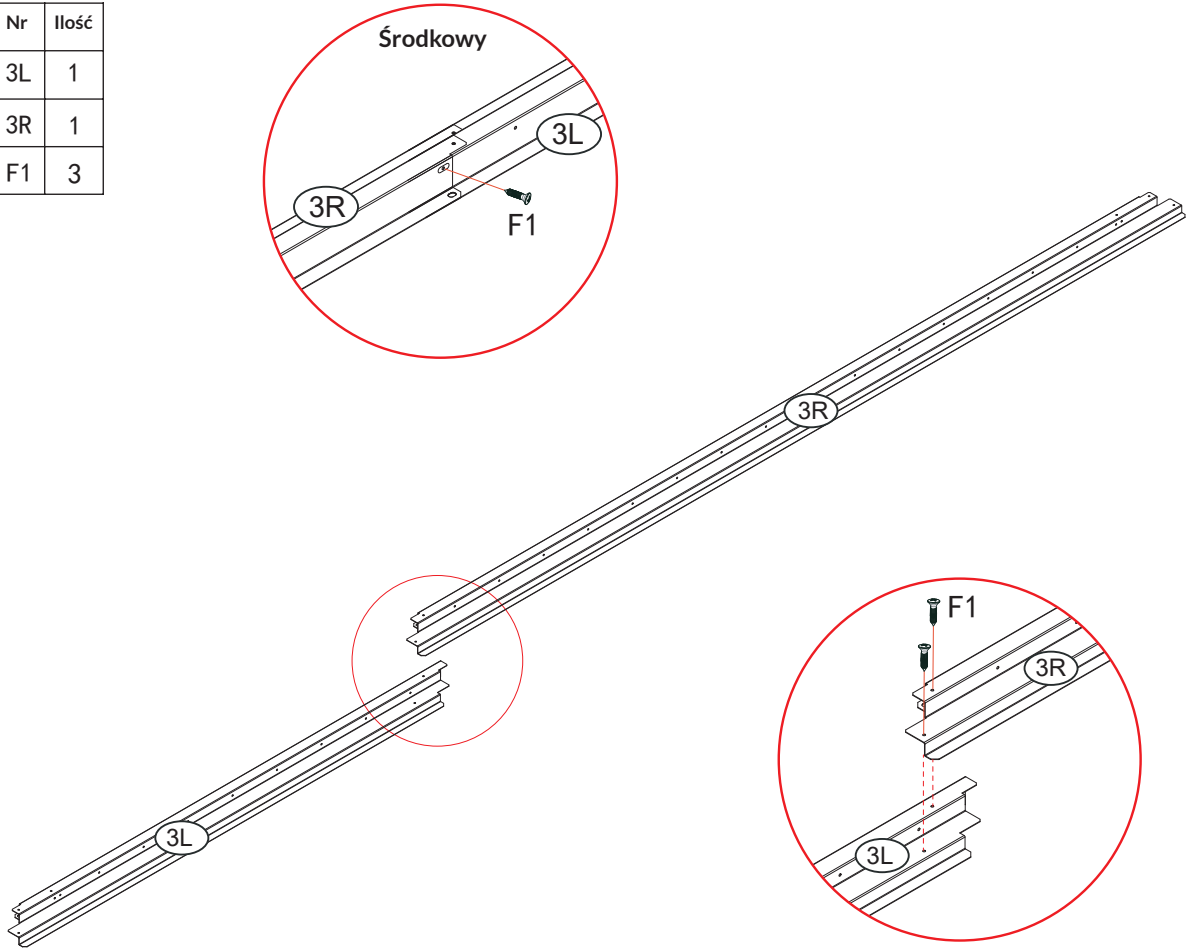

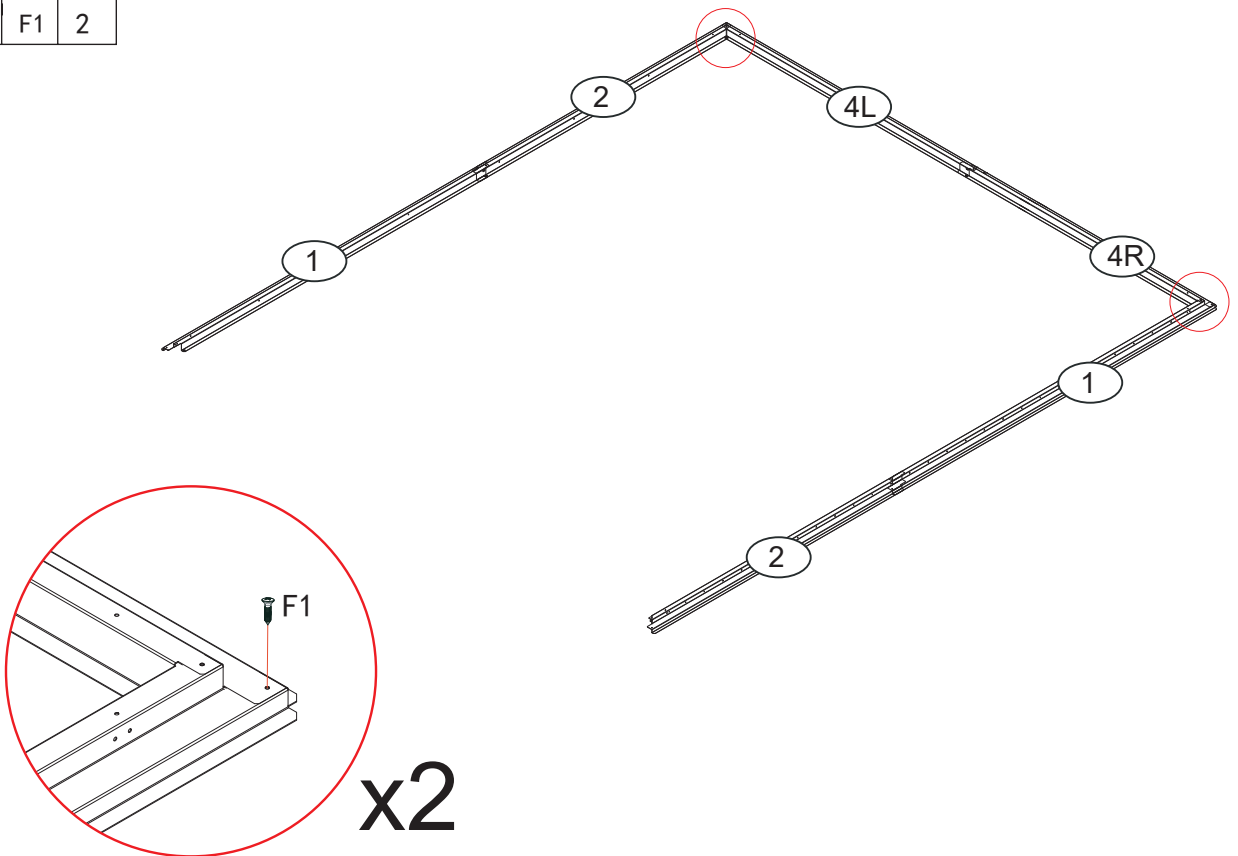

| Części  | Nr | Ilość |
|---|----|-------|
|  | 3L | 1     |
|  | 3R | 1     |
|  | F1 | 3     |







| Części  | Nr | Ilość |
|---|----|-------|
|  | F1 | 2     |



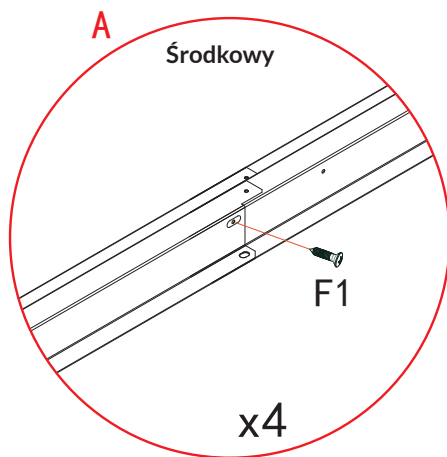
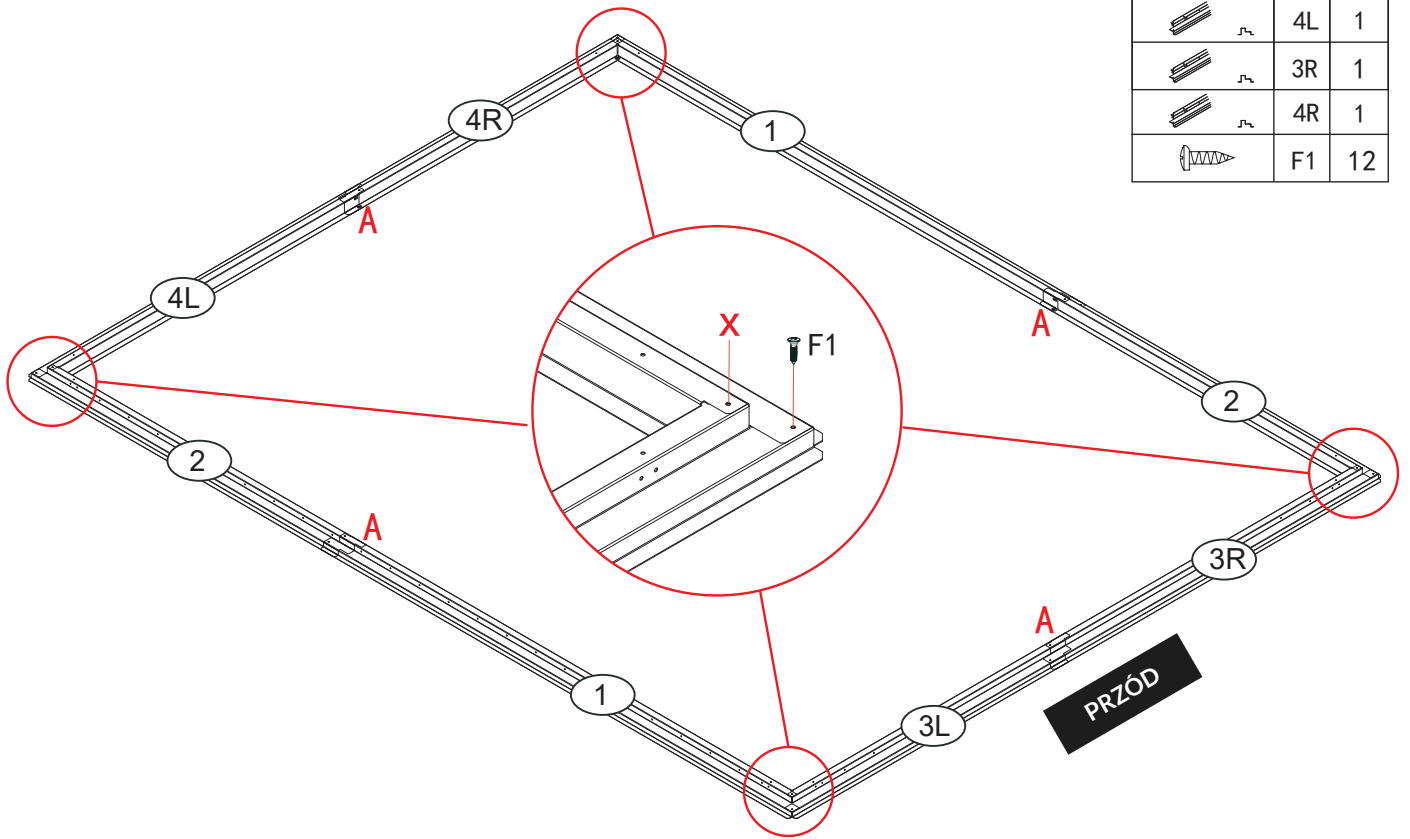

| Części  | Nr | Ilość |
|---|----|-------|
|  | 1  | 1     |
|  | 2  | 1     |
|  | 3L | 1     |
|  | 4L | 1     |
|  | 3R | 1     |
|  | 4R | 1     |
|  | F1 | 12    |





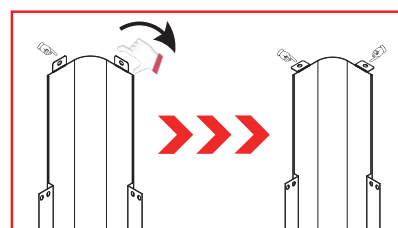
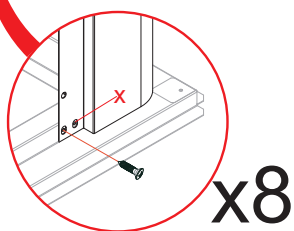
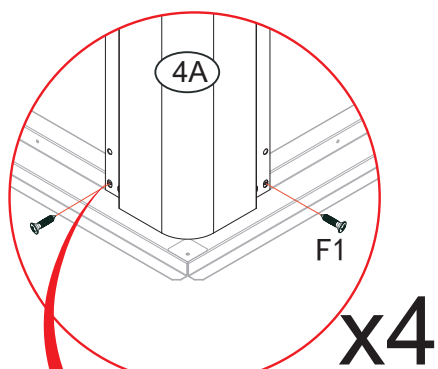
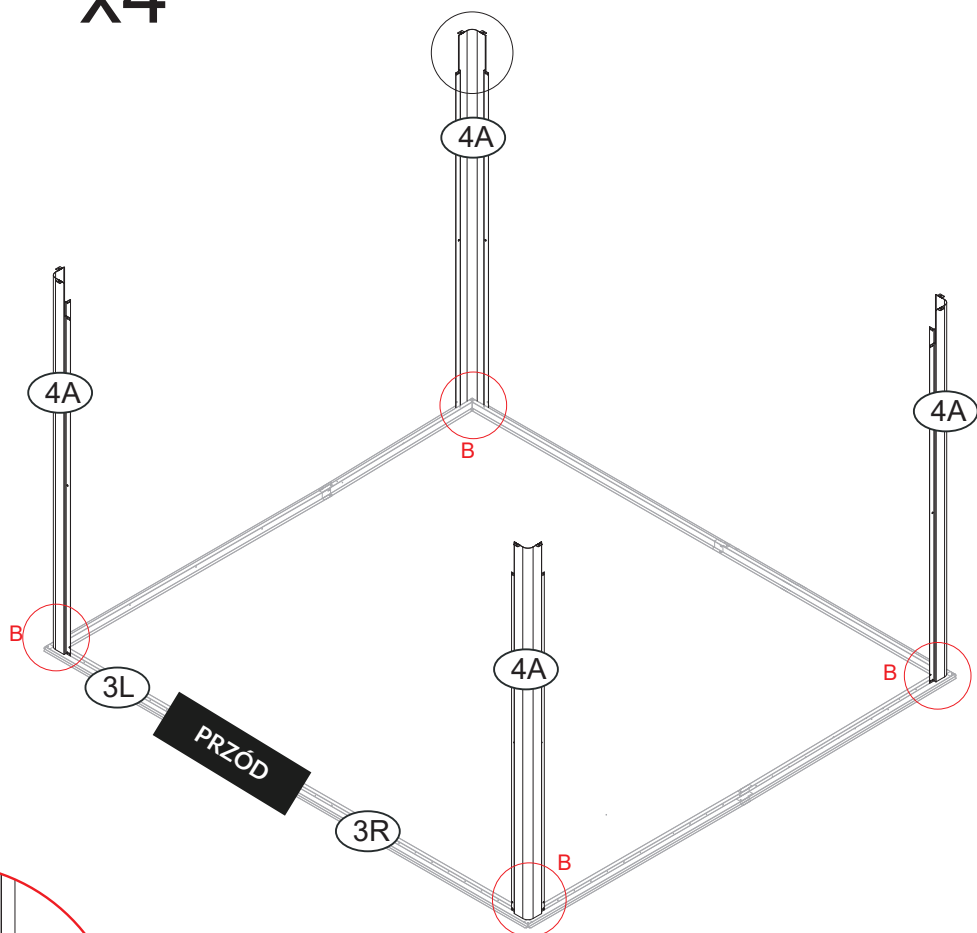
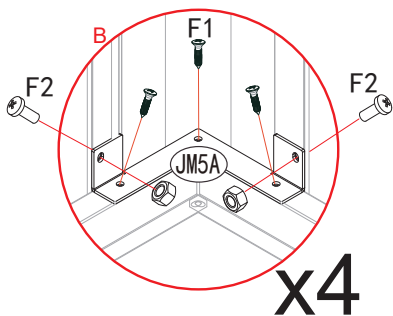

| Części  | Nr   | Ilość |
|---|------|-------|
|  | JM5A | 4     |
|  | 4A   | 4     |
|  | F1   | 20    |
|  | F2   | 8     |



Zegnij ręcznie pod kątem 90°



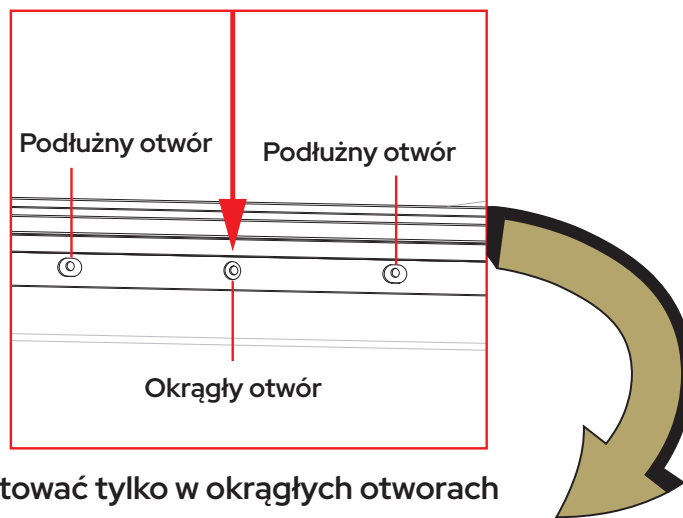
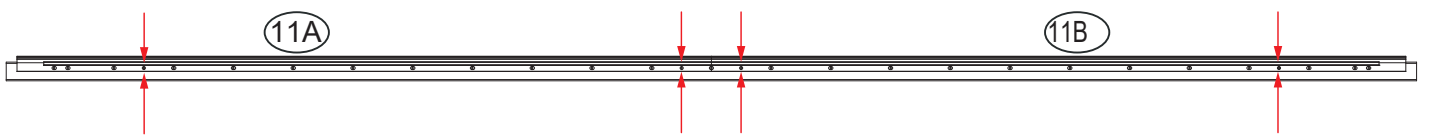
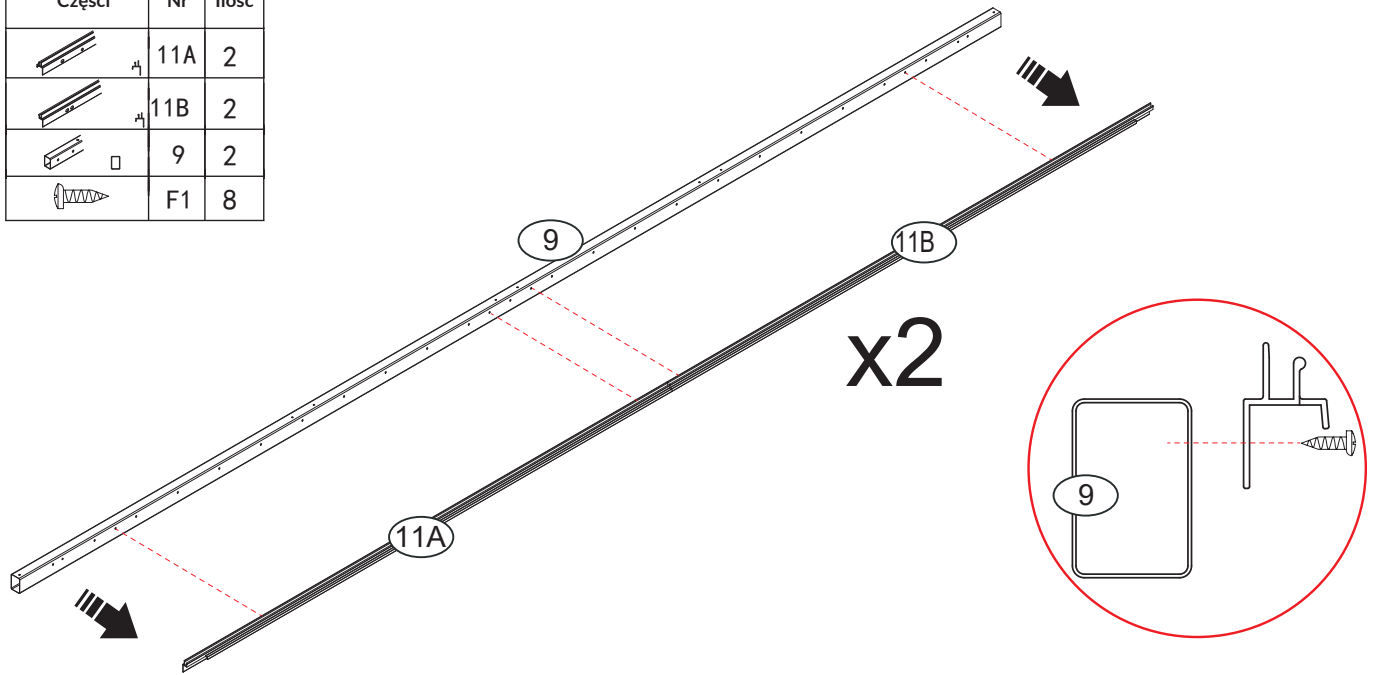

**Uwaga: Śruby należy zamontować tylko w pokazanych pozycjach – pozostałe otwory nie są do montażu.**

| Części  | Nr  | Ilość |
|---|-----|-------|
|  | 11A | 2     |
|  | 11B | 2     |
|  | 9   | 2     |
|  | F1  | 8     |

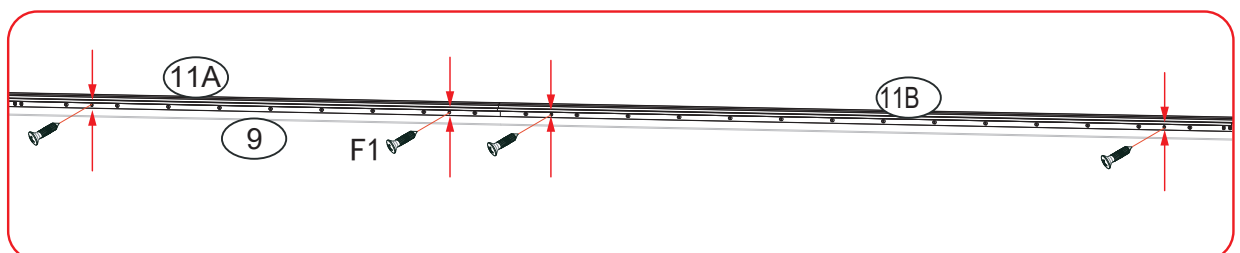

Montować tylko w okrągłych otworach





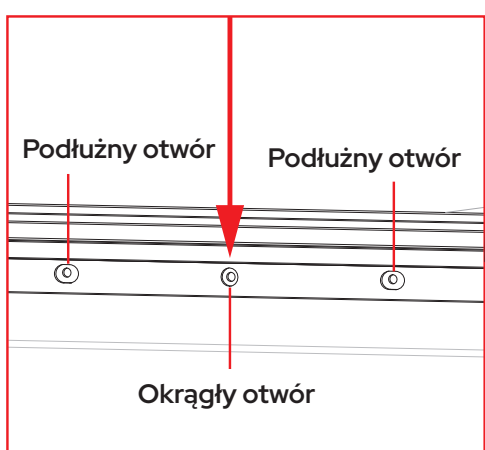
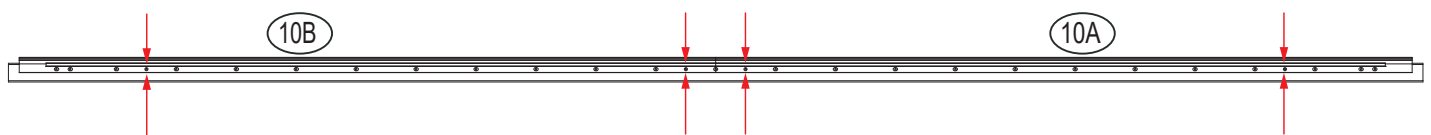
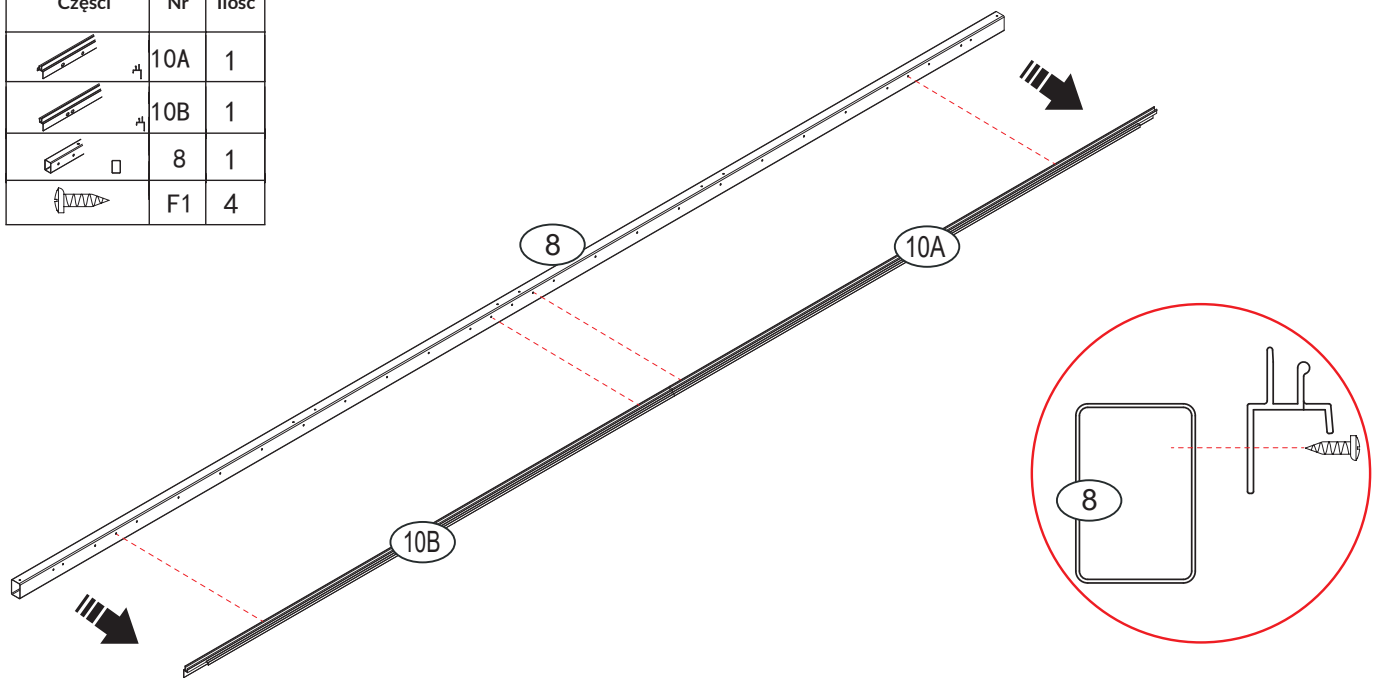

| Części  | Nr  | Ilość |
|---|-----|-------|
|  | 10A | 1     |
|  | 10B | 1     |
|  | 8   | 1     |
|  | F1  | 4     |

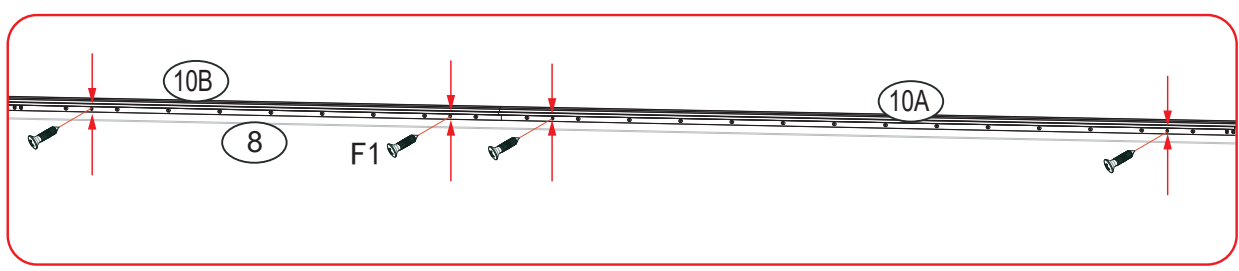

Montować tylko w okrągłych otworach



| Części  | Nr | Ilość |
|---|----|-------|
|  | 7A | 1     |
|  | 7B | 1     |
|  | 7  | 1     |
|  | F1 | 4     |

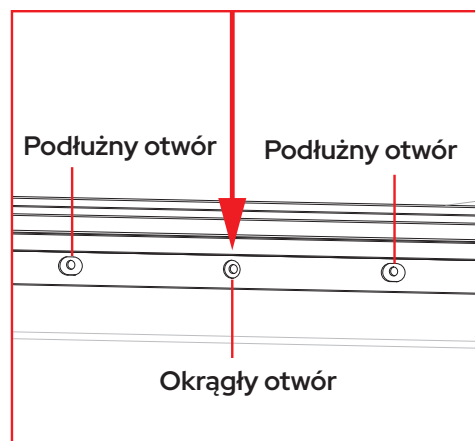
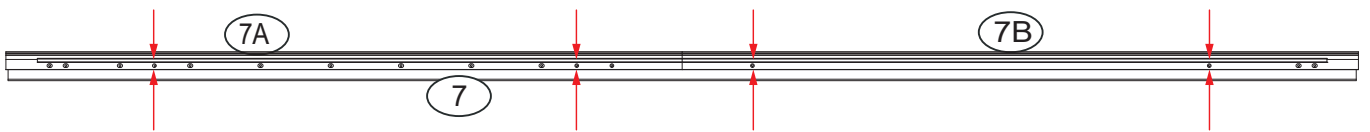
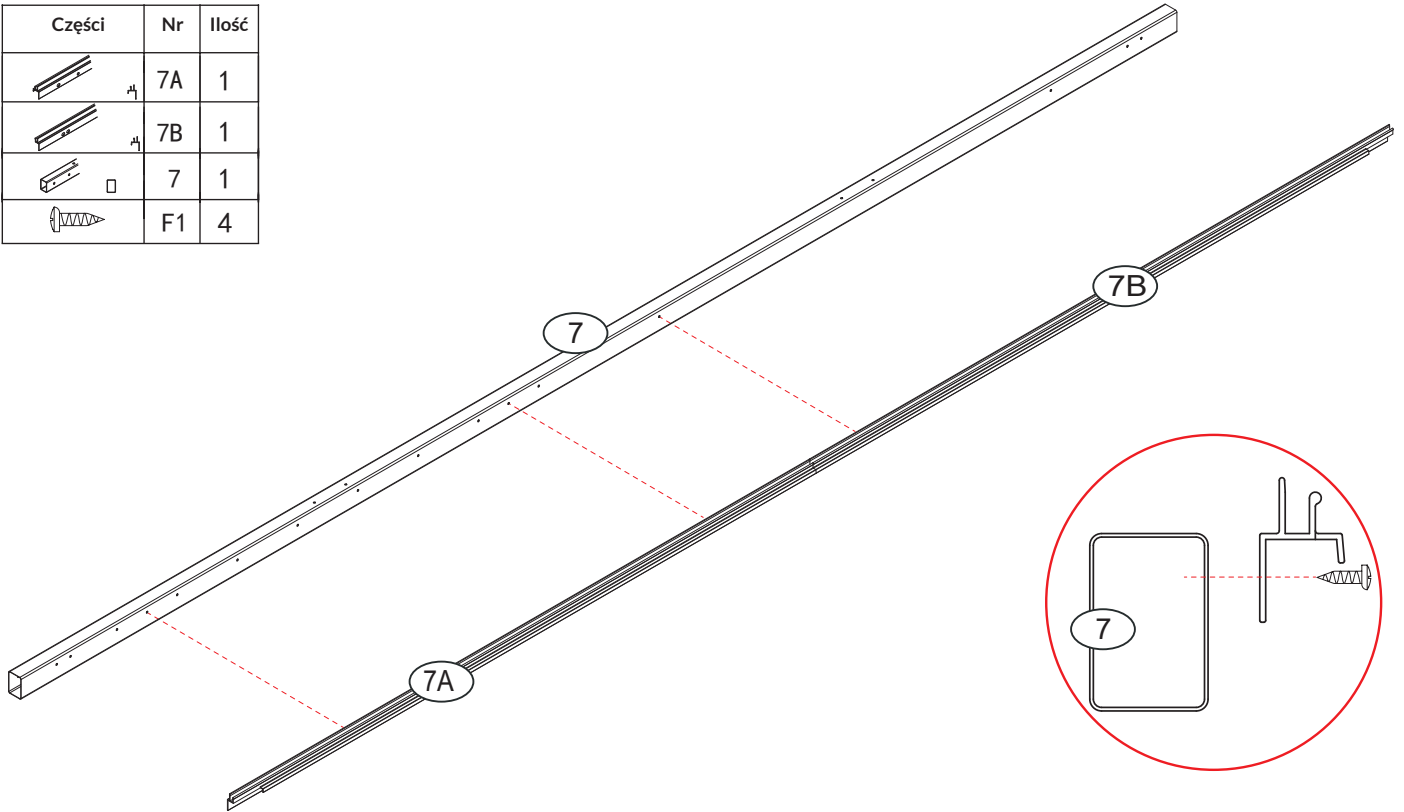

Montować tylko w okrągłych otworach

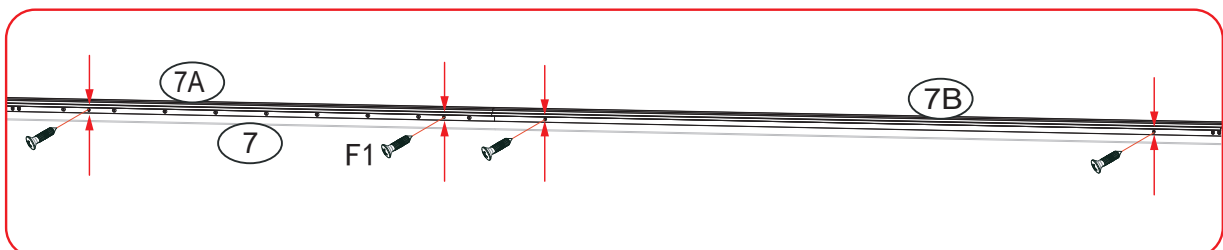

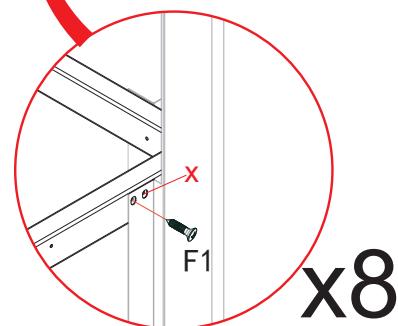
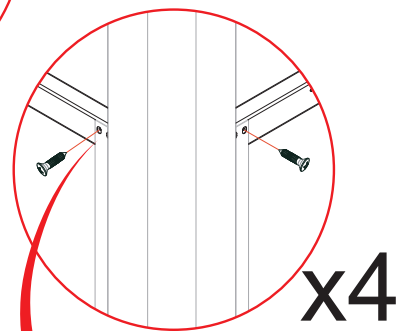
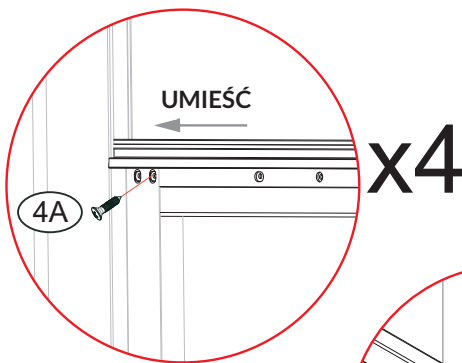
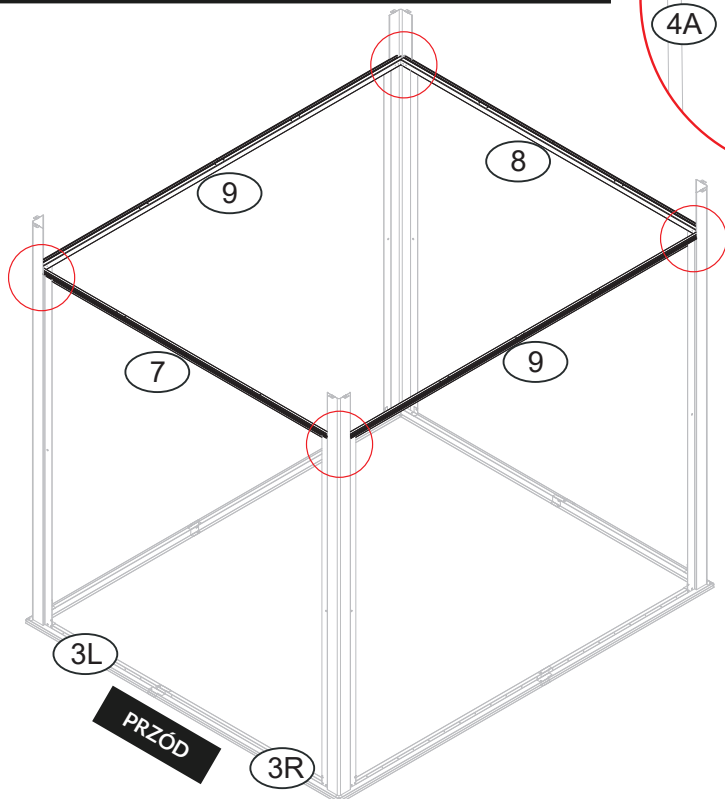

| Części  | Nr | Ilość |
|---|----|-------|
|  | F1 | 8     |

7, 8, 9, Jedna ze stron konstrukcji powinna być skierowana na zewnątrz.

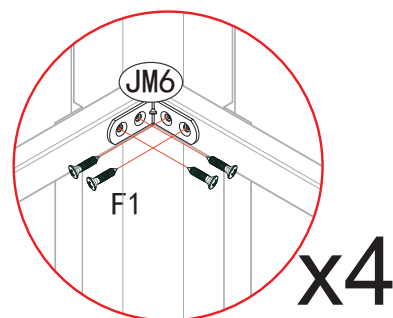
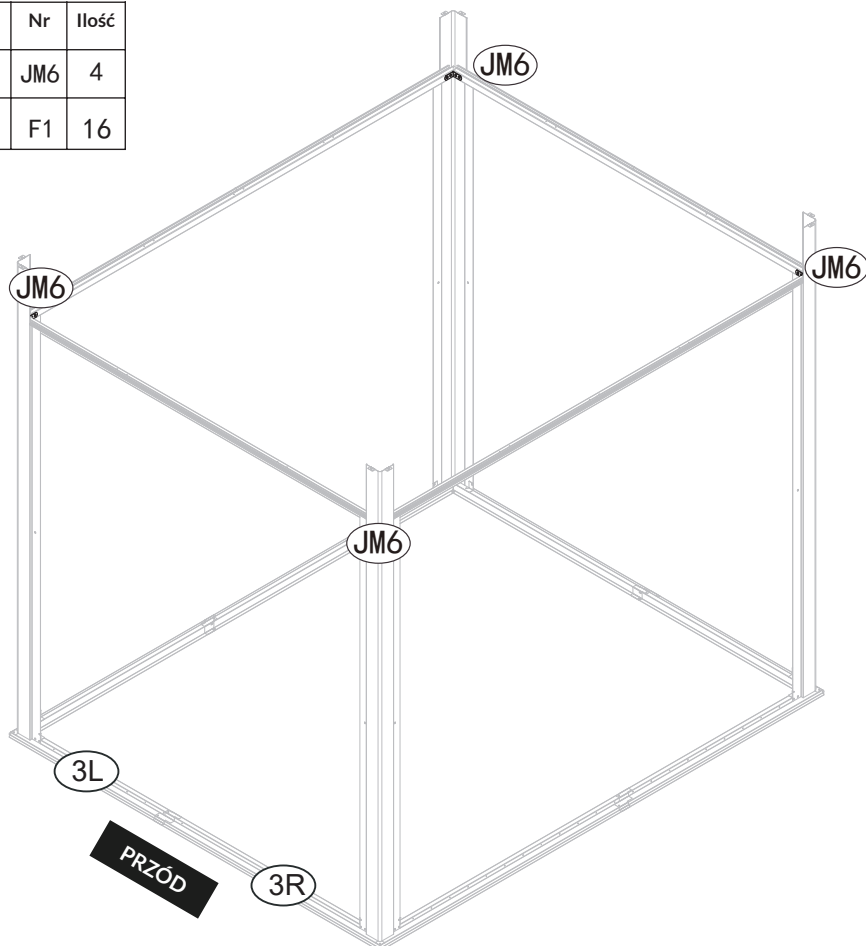

| Części  | Nr  | Ilość |
|---|-----|-------|
|  | JM6 | 4     |
|  | F1  | 16    |



| Części  | Nr | Ilość |
|---|----|-------|
|  | B1 | 4     |
|  | F1 | 4     |

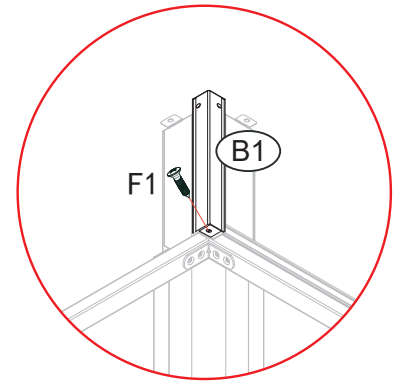
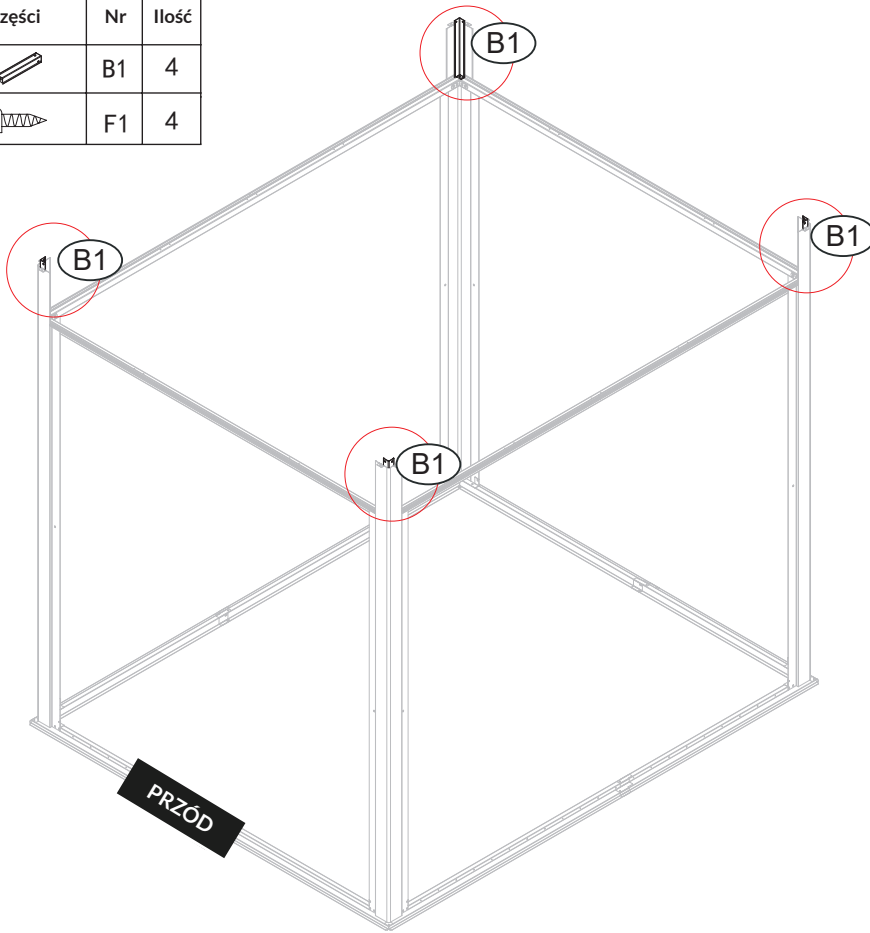



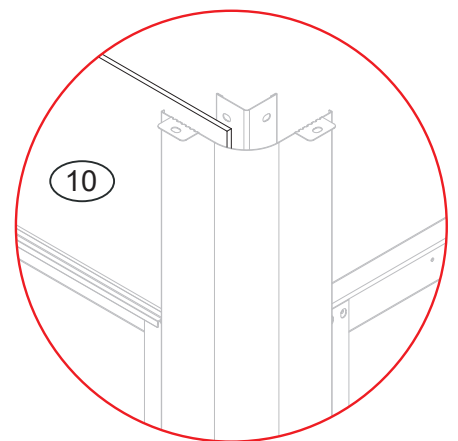
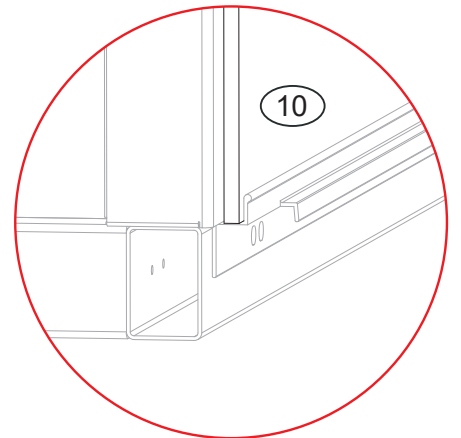
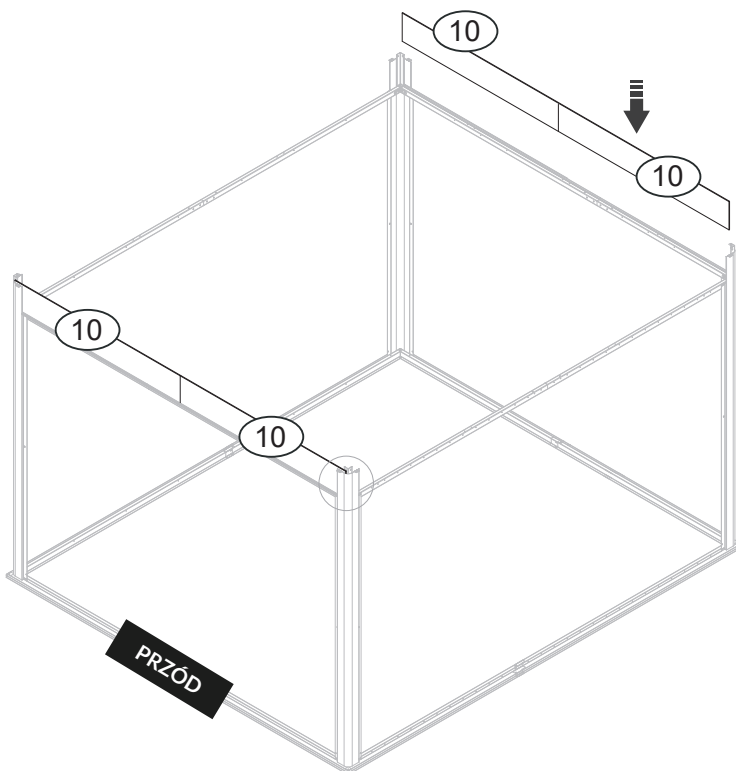

| Części  | Nr | Ilość |
|---|----|-------|
|  | 10 | 4     |

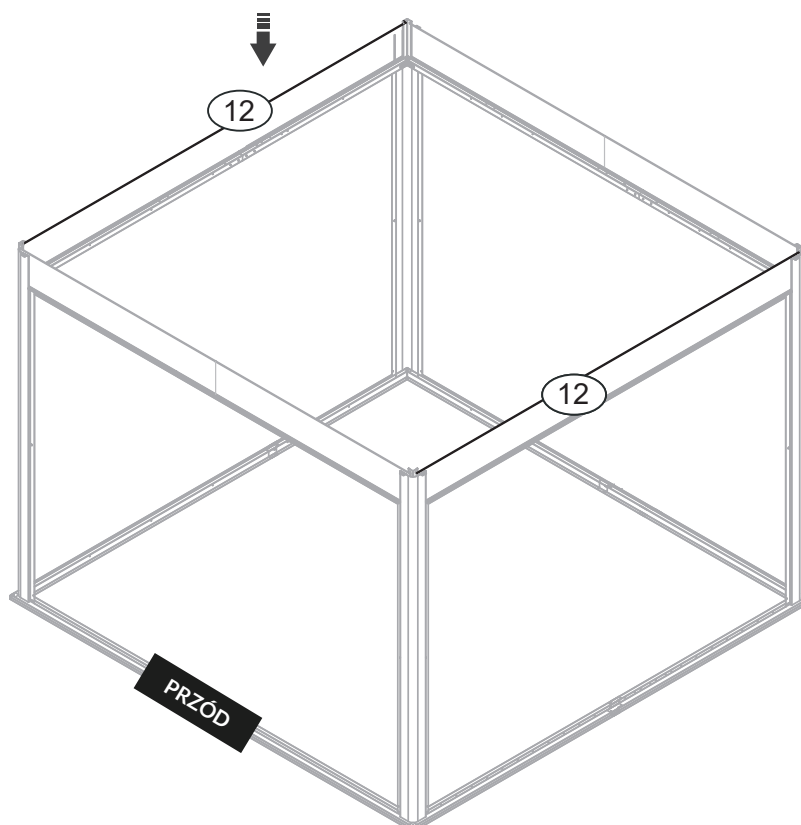
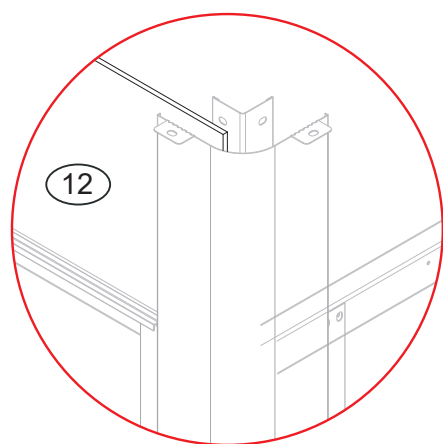
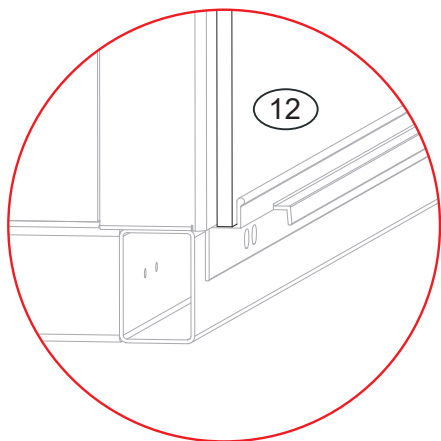

| Części  | Nr | Ilość |
|---|----|-------|
|  | 12 | 2     |



| Części  | Nr  | Ilość |
|---|-----|-------|
|  | 15A | 2     |
|  | 15B | 2     |
|  | 17A | 2     |
|  | 17B | 2     |

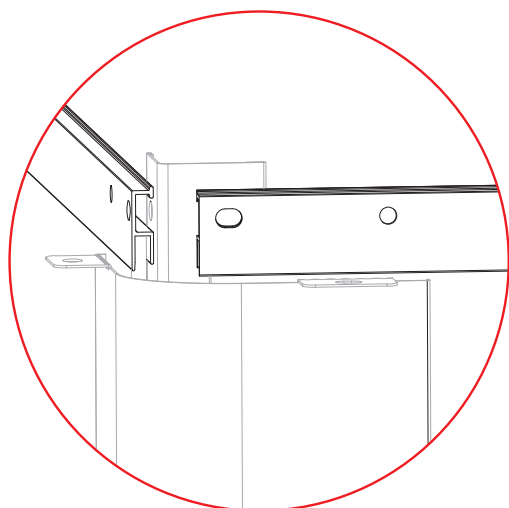
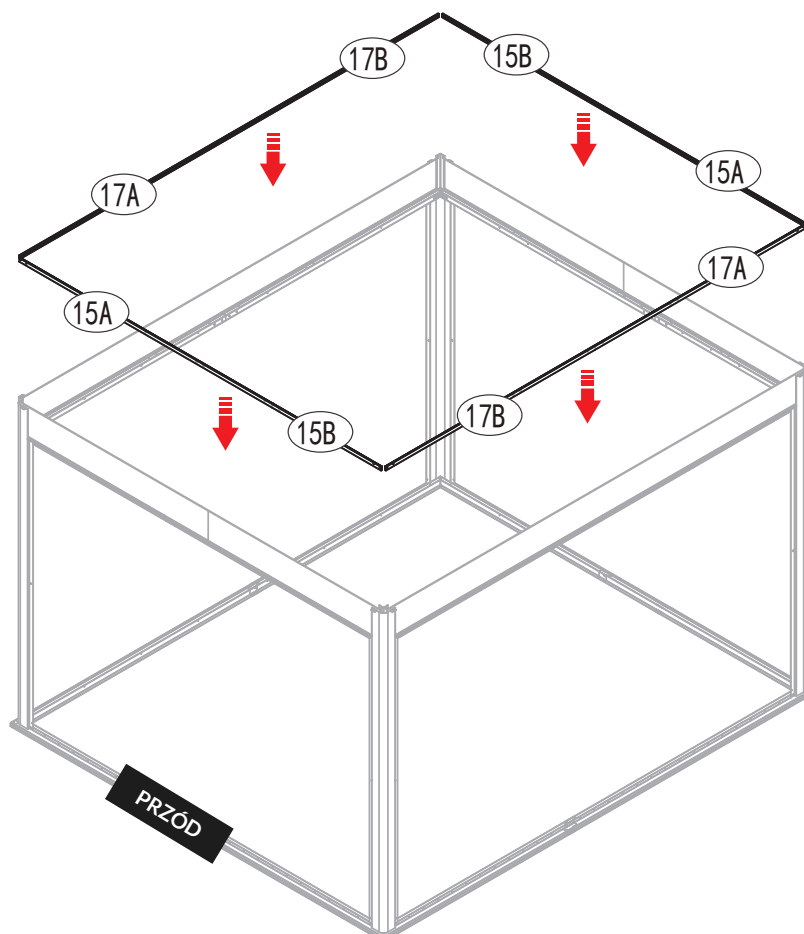



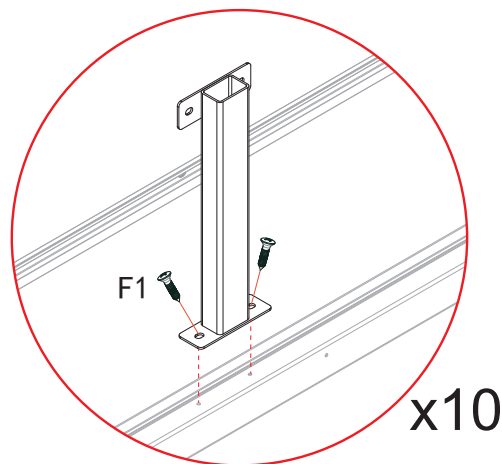
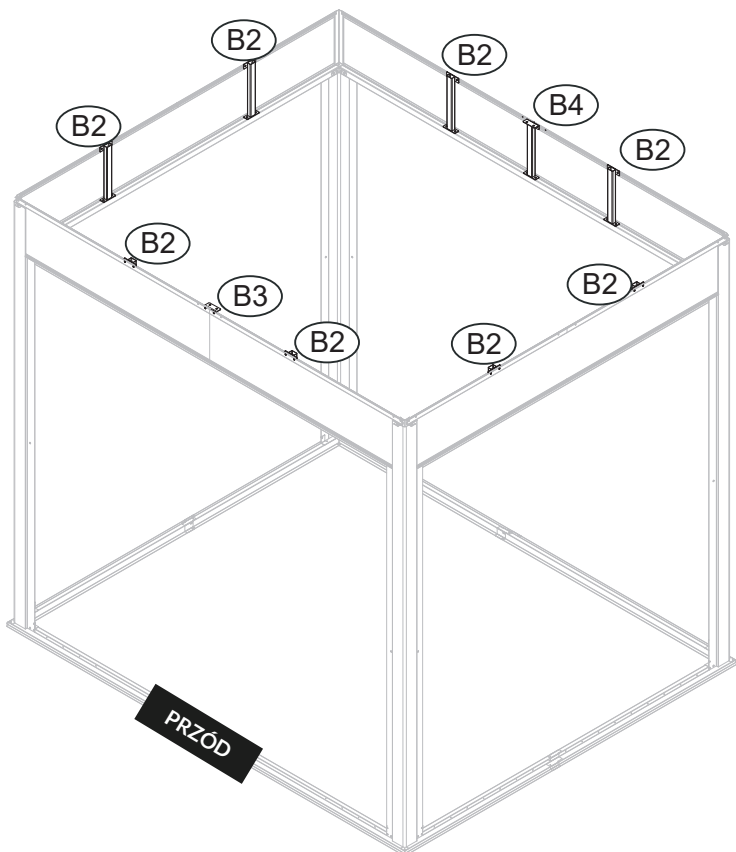





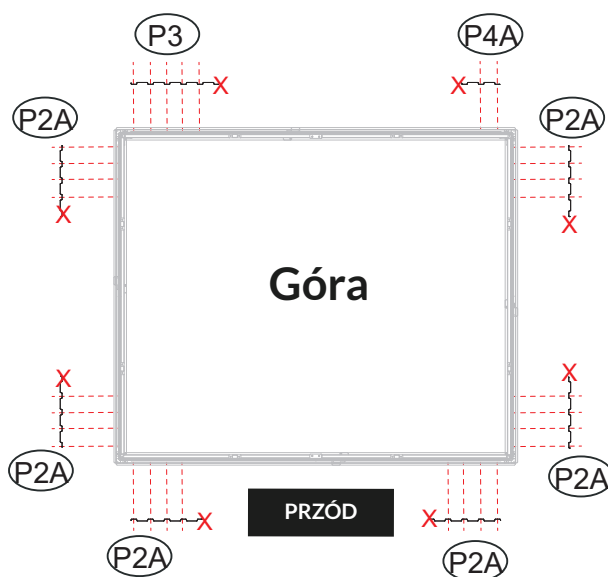
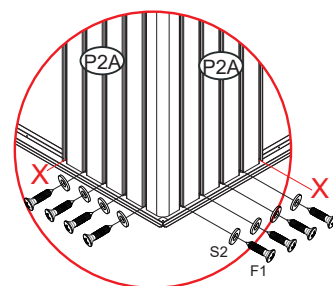
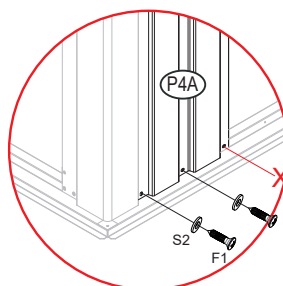
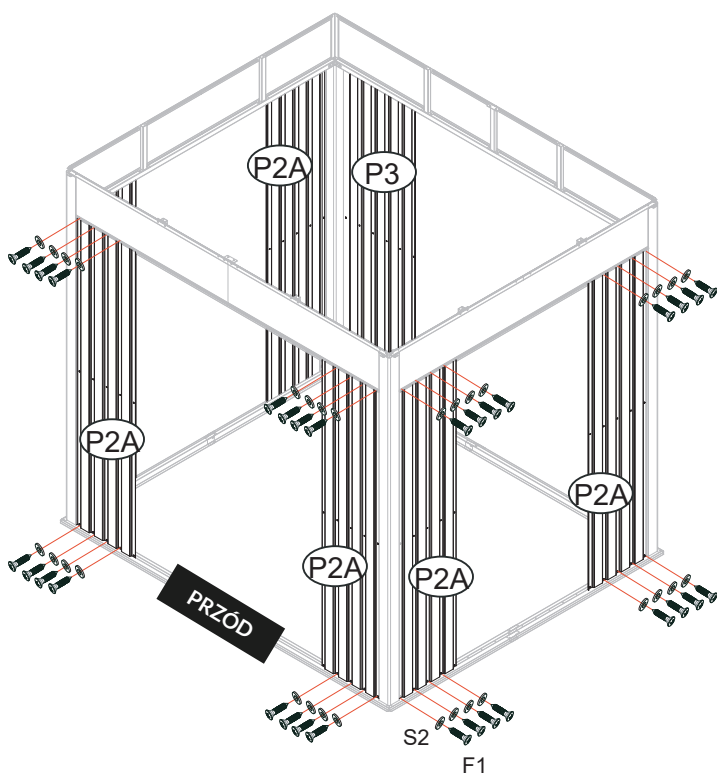



x10

| Części | Nr | Ilość |
|--------|----|-------|
|        | B2 | 8     |
|        | B3 | 1     |
|        | B4 | 1     |
|        | F1 | 20    |



| Części | Nr | Ilość |
|--------|----|-------|
|        | F1 | 60    |
|        | S2 | 60    |

| Części  | Nr  | Ilość |
|---|-----|-------|
|  | JM6 | 4     |
|  | 21L | 1     |
|  | 22  | 2     |
|  | 21R | 1     |
|  | 24  | 1     |
|  | F1  | 47    |
|  | S2  | 31    |

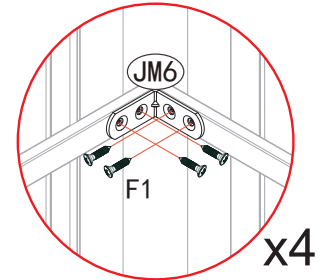
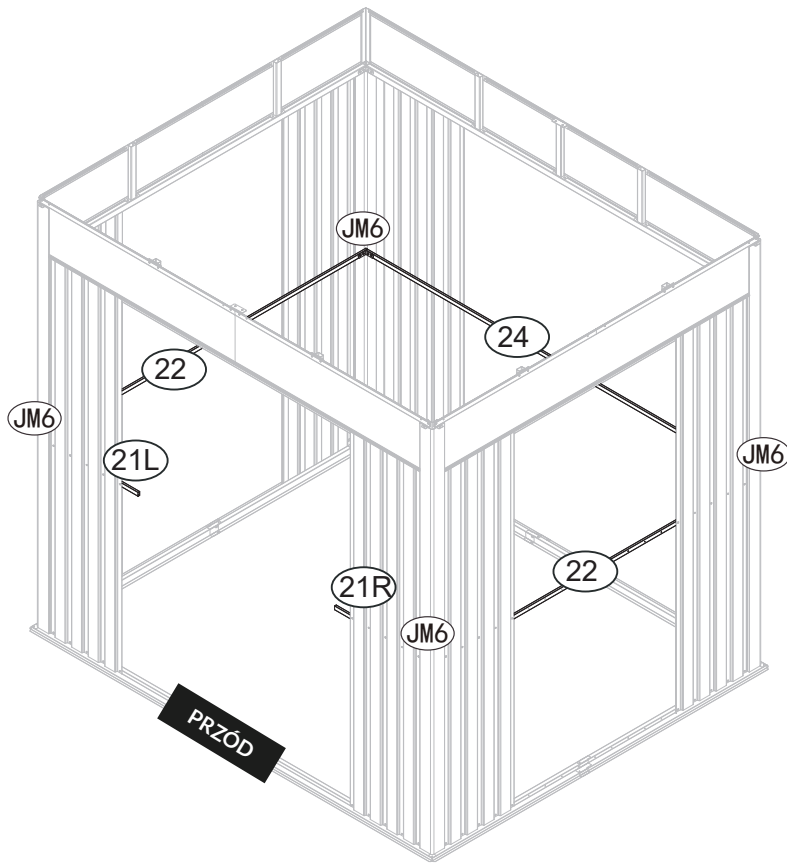



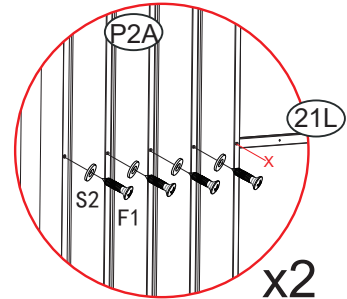

x4

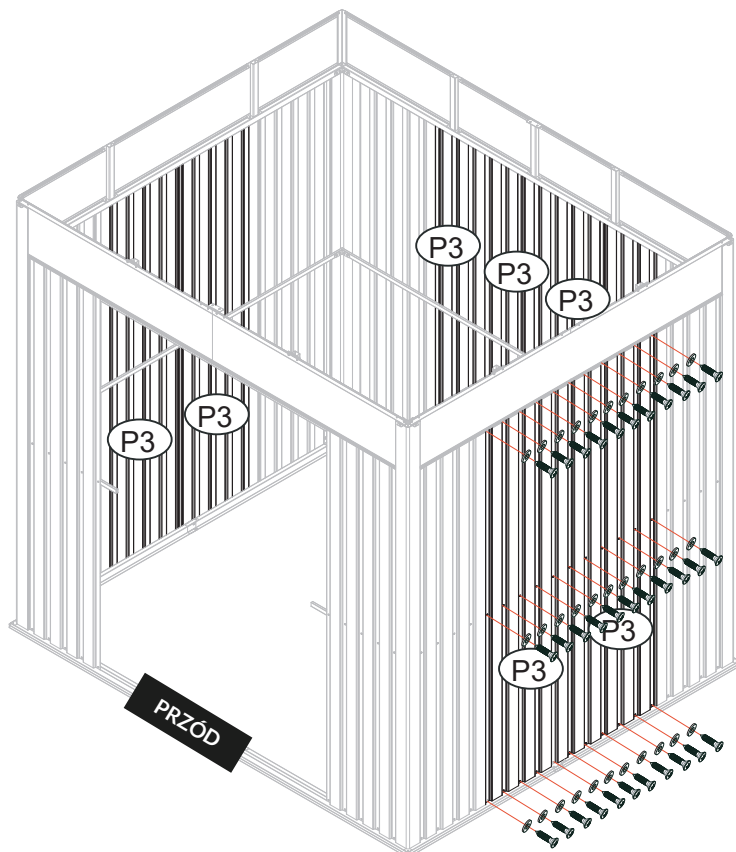

x2

| Części  | Nr | Ilość |
|---|----|-------|
|  | P3 | 7     |
|  | F1 | 100   |
|  | S2 | 100   |



| Części  | Nr  | Ilość |
|---|-----|-------|
|  | 25L | 1     |
|  | 25R | 1     |
|  | F1  | 10    |
|  | S2  | 10    |

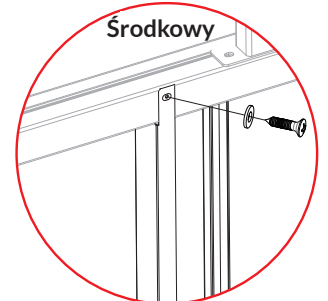
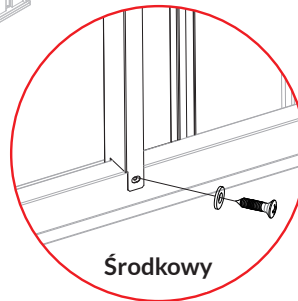
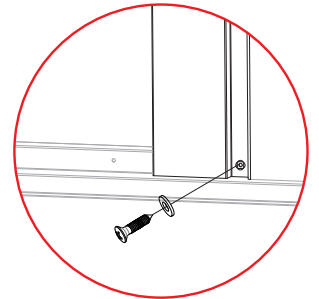
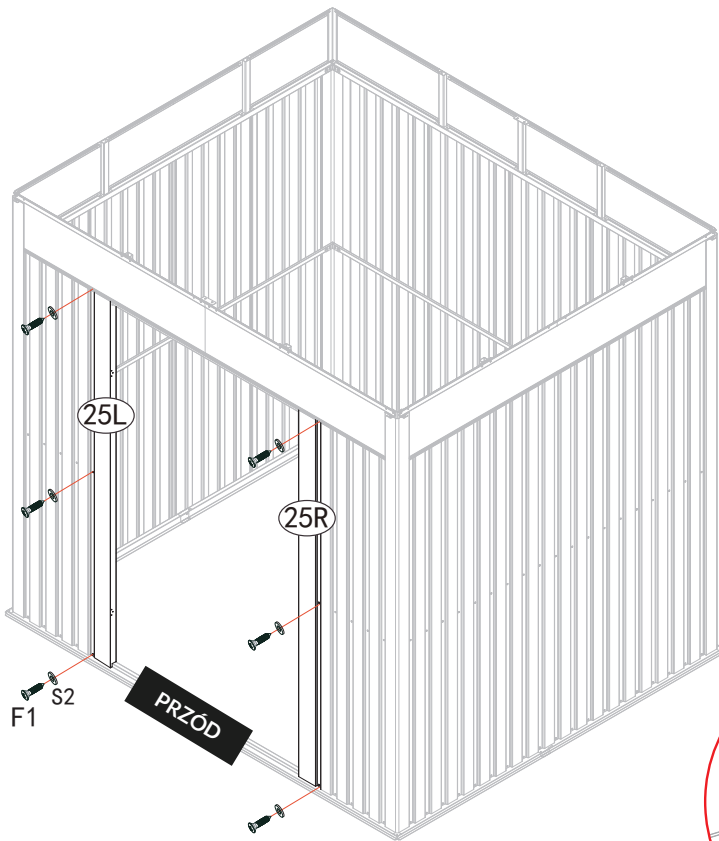

| Części  | Nr | Ilość |
|---|----|-------|
|  | 13 | 1     |
|  | F1 | 4     |

**Uwaga: Sprawdź pozycję otworów w części Nr. 13**

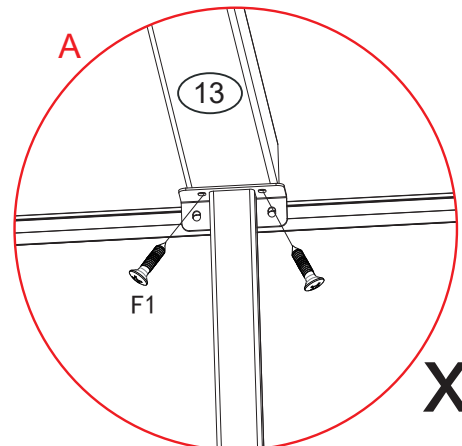
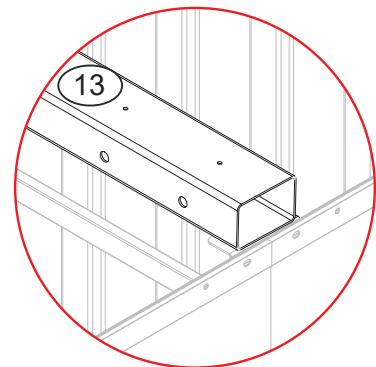
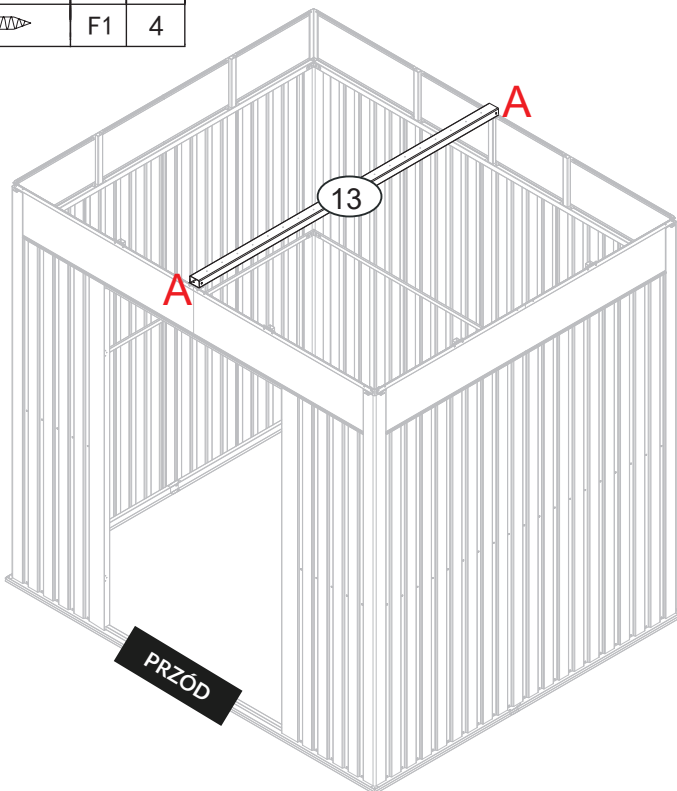

**x2**

Montaż 15L i 15R odbywa się w ten sam sposób

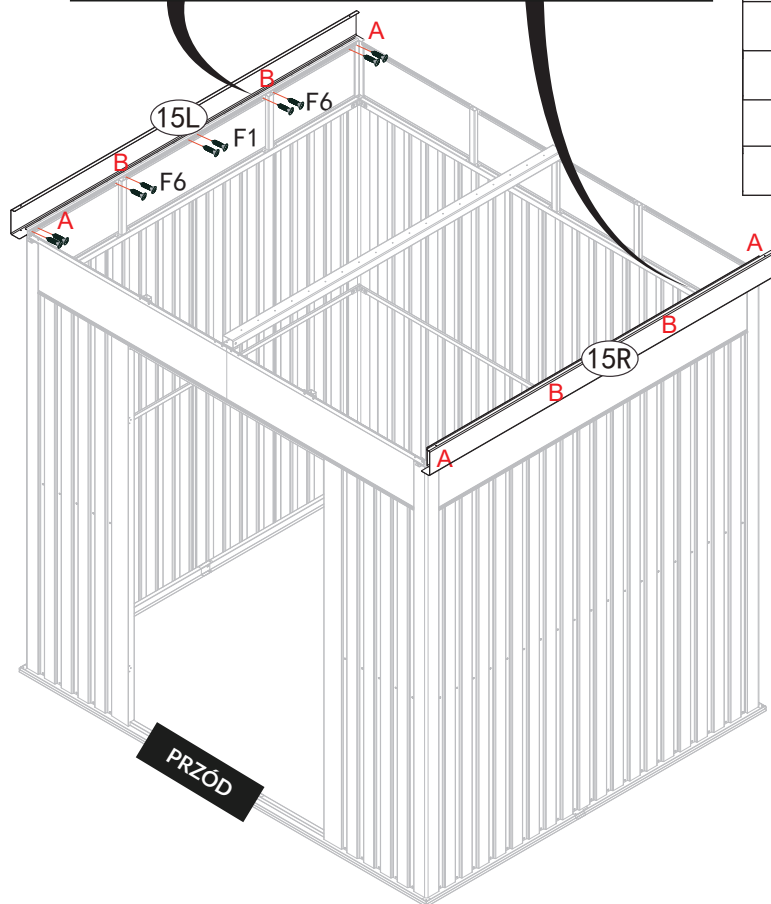

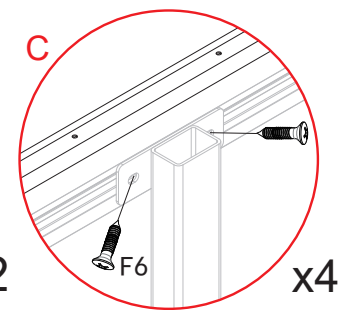
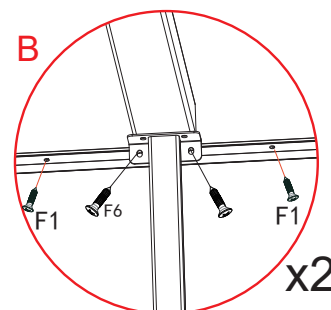
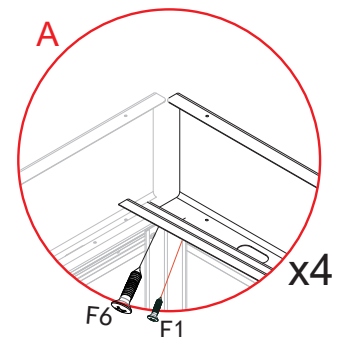
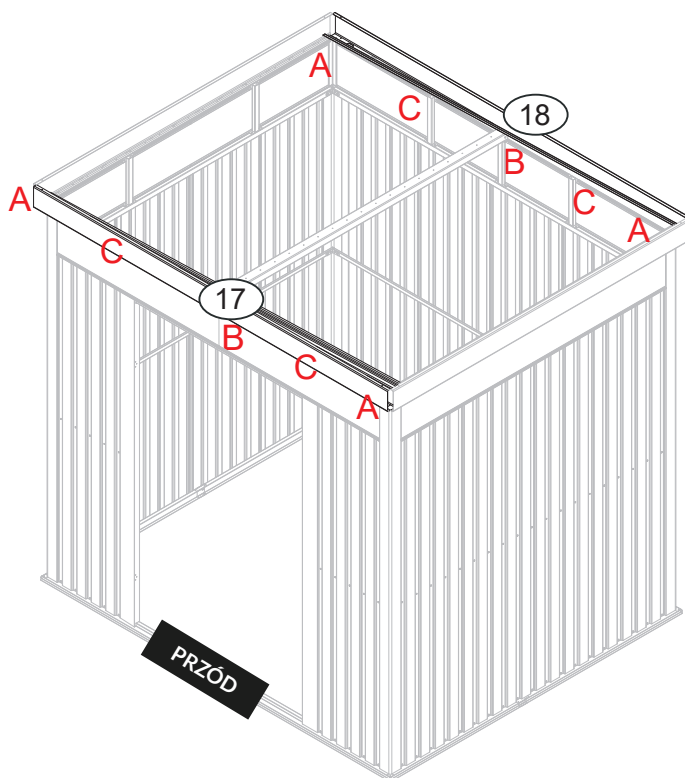
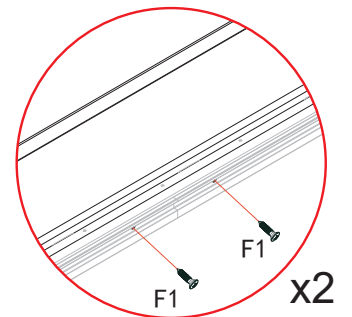
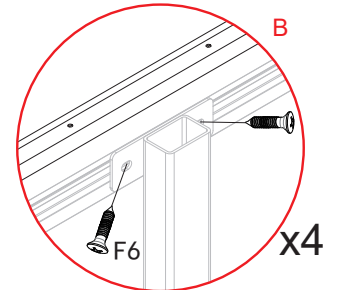
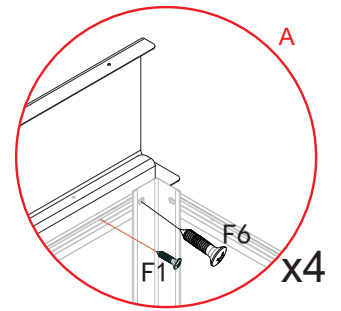

| Części | Nr  | Ilość |
|--------|-----|-------|
|        | 15L | 1     |
|        | 16R | 1     |
|        | F6  | 16    |
|        | F1  | 8     |



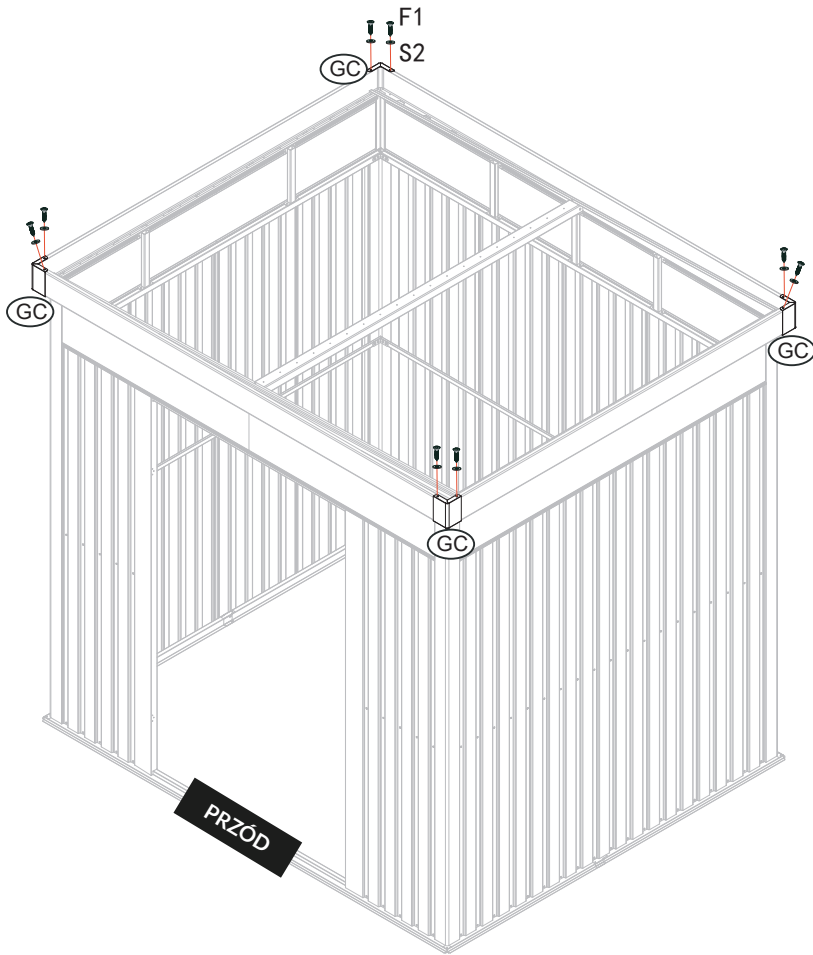



| Części | Nr | Ilość |
|--------|----|-------|
|        | 17 | 1     |
|        | 18 | 1     |
|        | F6 | 16    |
|        | F1 | 8     |

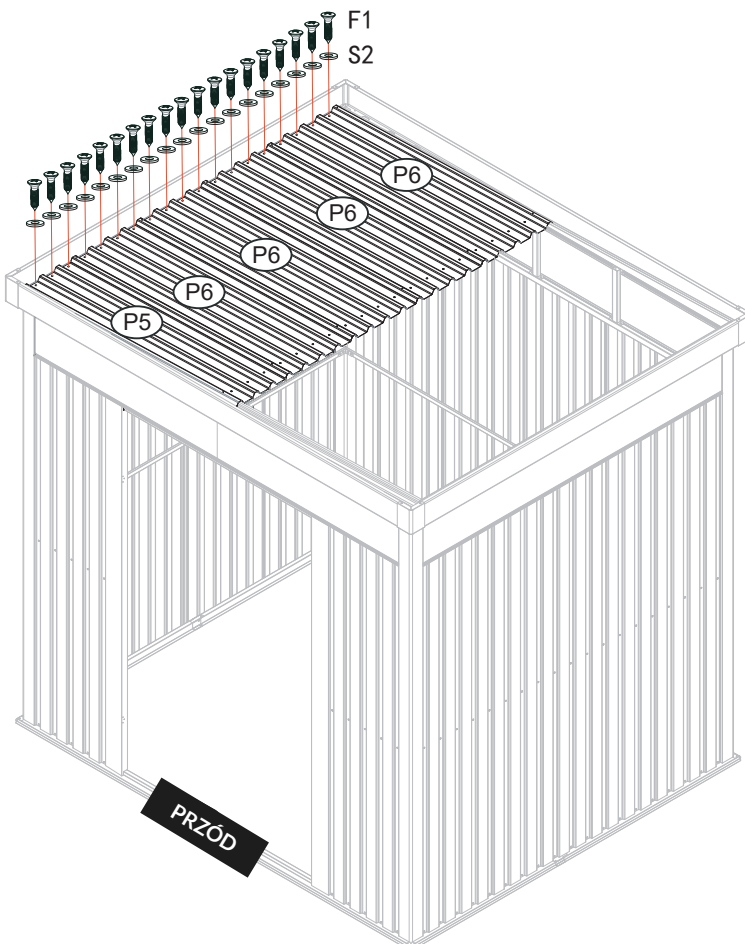
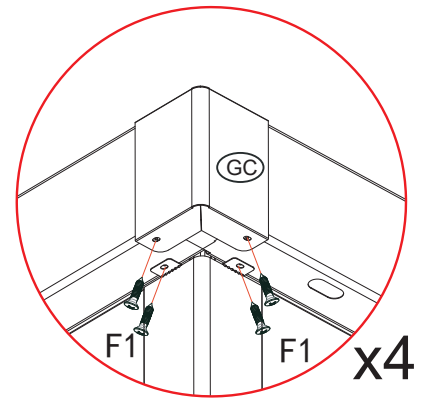





| Części  | Nr | Ilość |
|---|----|-------|
|  | GC | 4     |
|  | F1 | 24    |
|  | S2 | 8     |

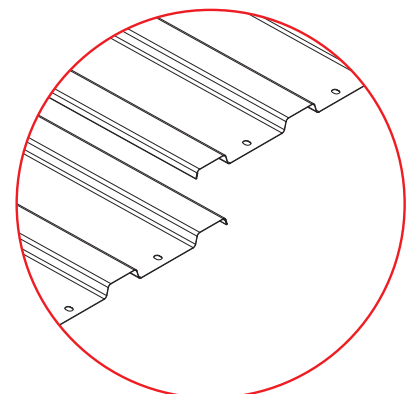

| Części  | Nr | Ilość |
|---|----|-------|
|  | P5 | 1     |
|  | P6 | 4     |
|  | F1 | 19    |
|  | S2 | 19    |

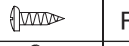

| Części  | Nr | Ilość |
|---|----|-------|
|  | P7 | 1     |
|  | P8 | 4     |
|  | F1 | 38    |
|  | S2 | 38    |

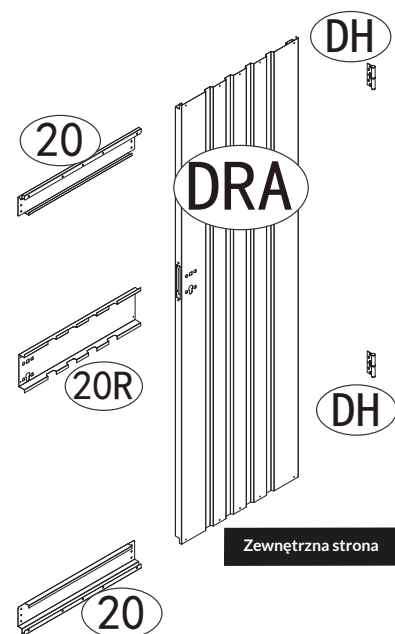
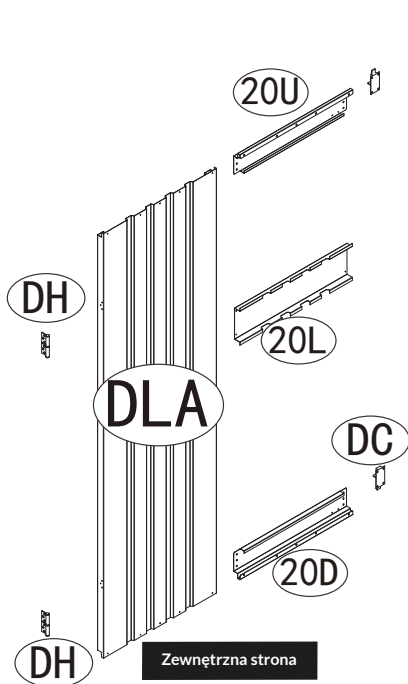
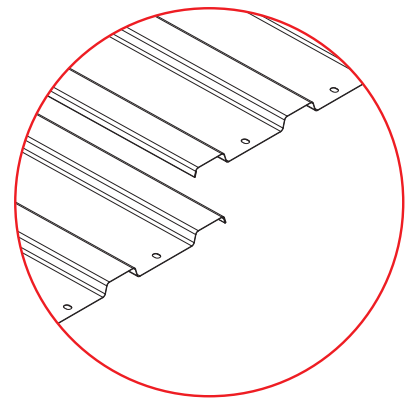
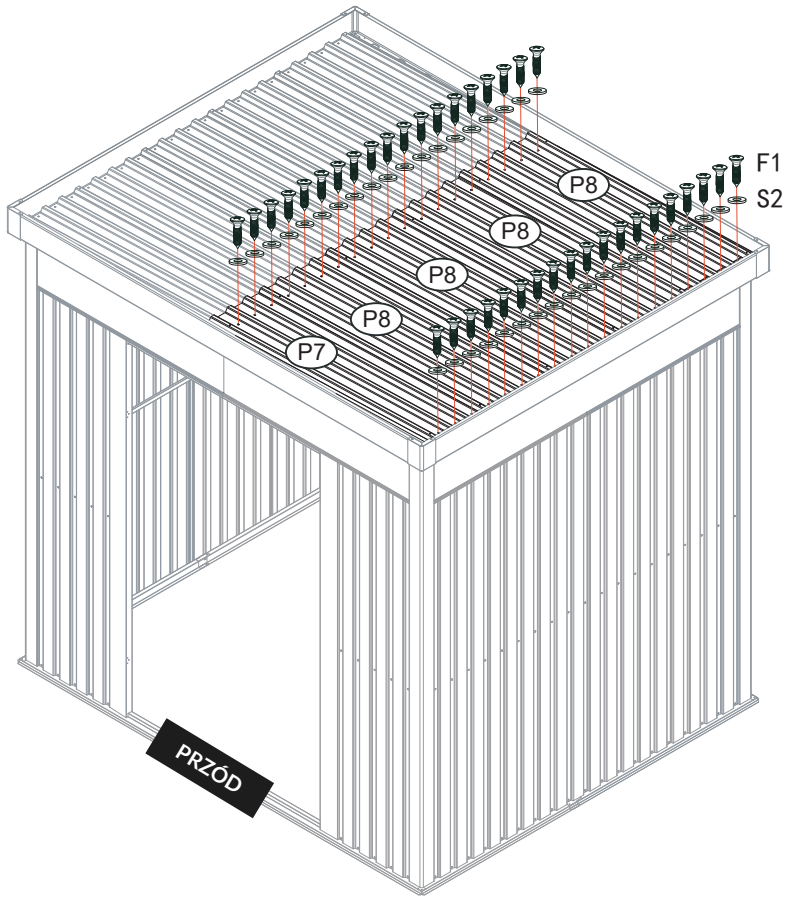

Przed montażem drzwi przygotuj i uporządkuj pokazane elementy.

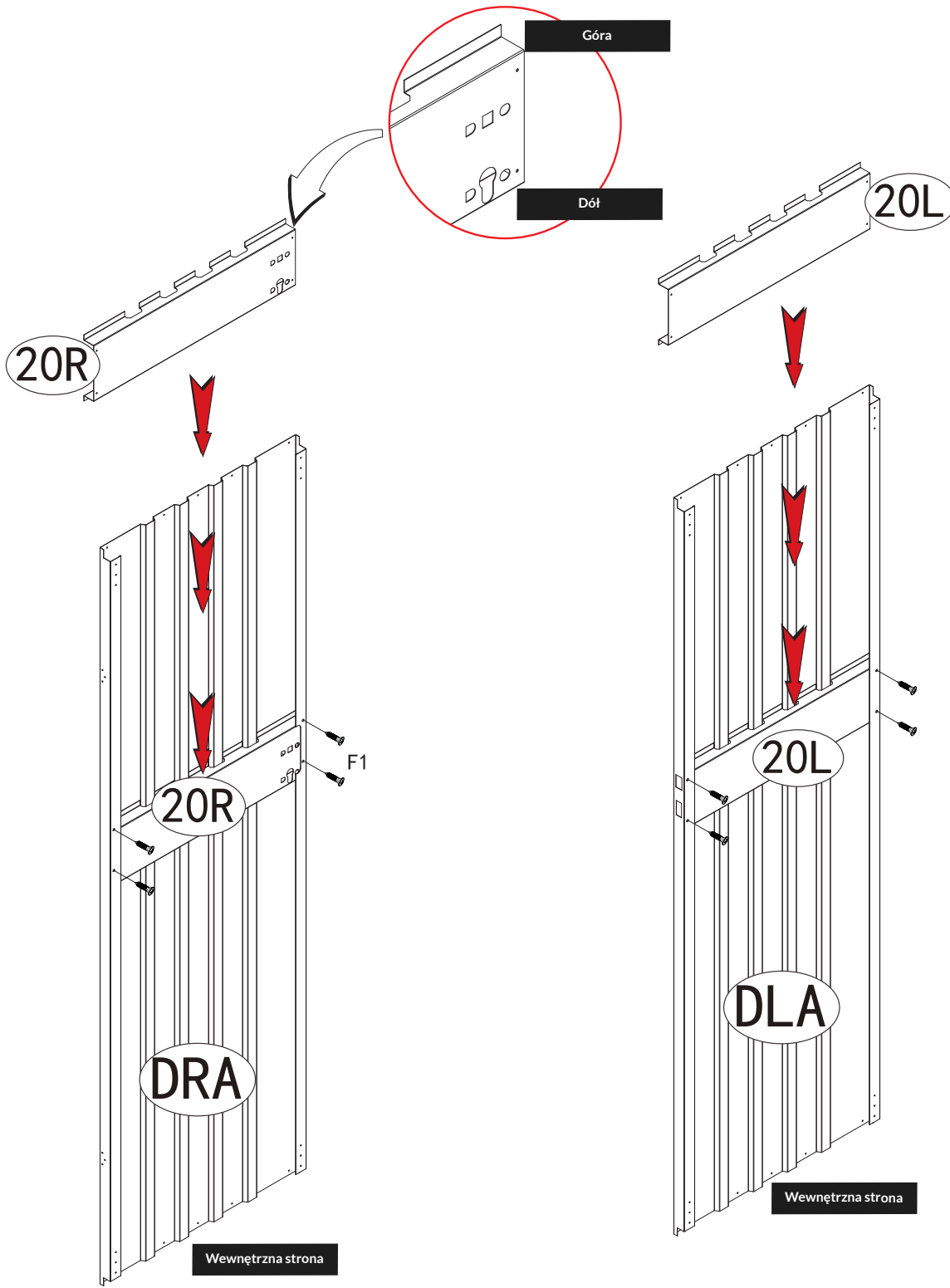

| Części  | Nr | Ilość |
|---|----|-------|
|  | F1 | 8     |

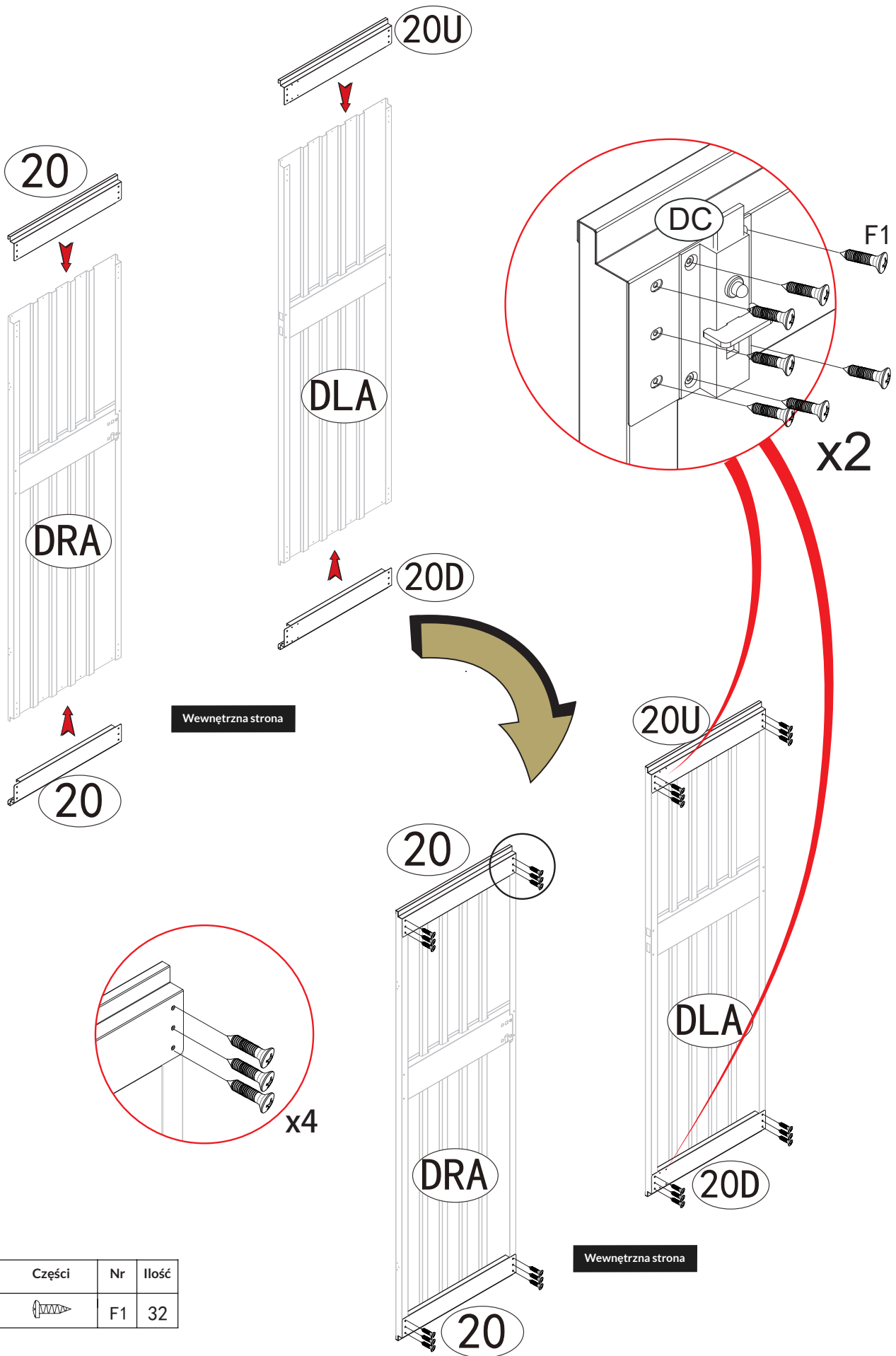

| Części  | Nr | Ilość |
|---|----|-------|
|  | F1 | 32    |



Przed ponowną instalacją zamka należy przygotować następujące części

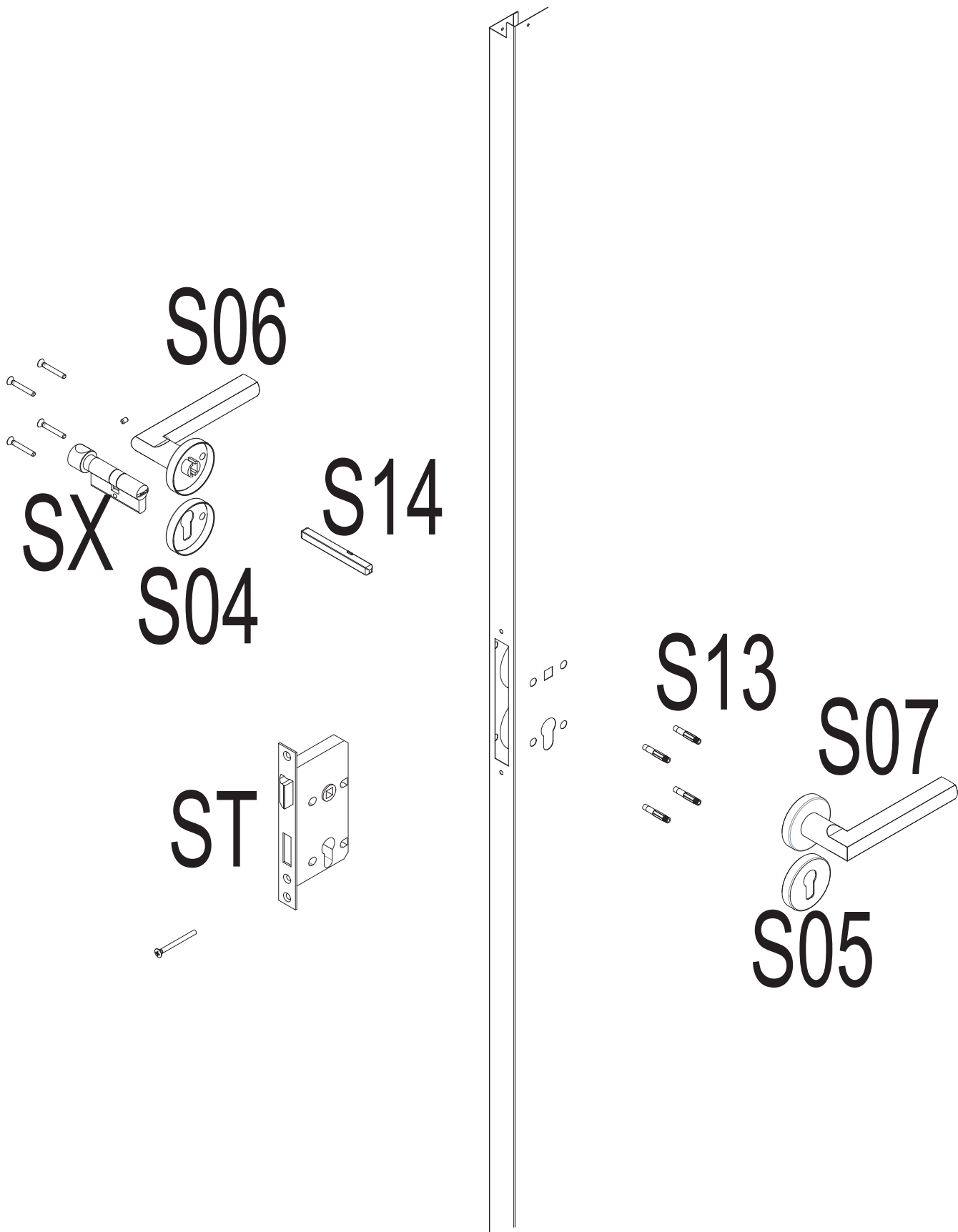

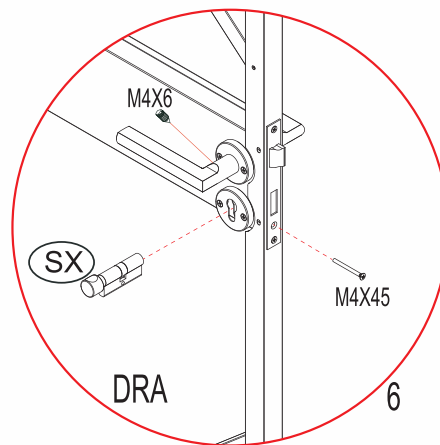
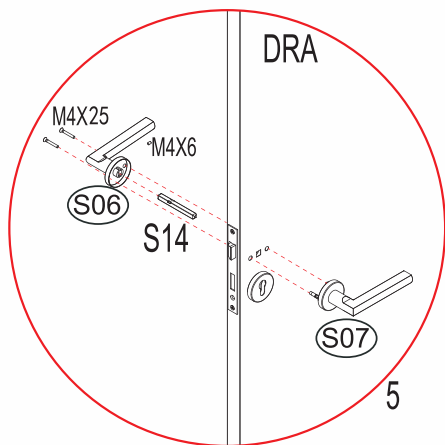
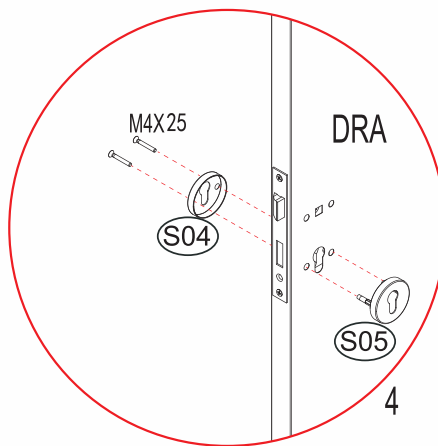
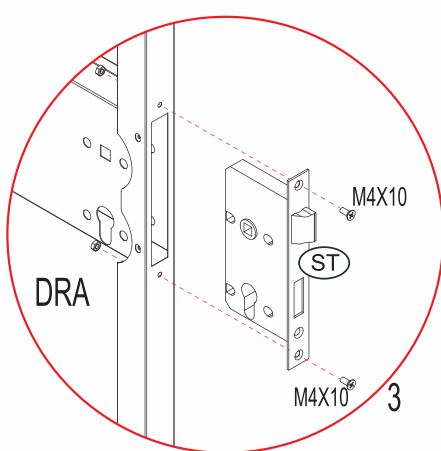
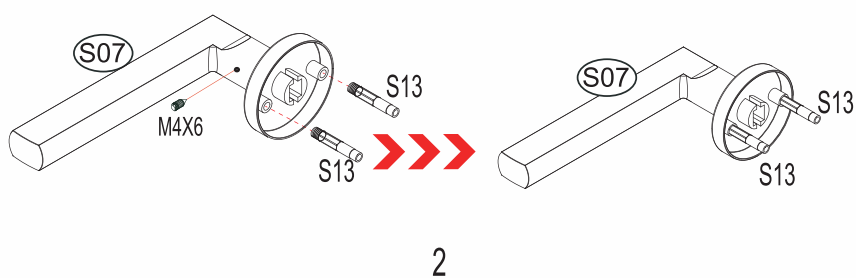
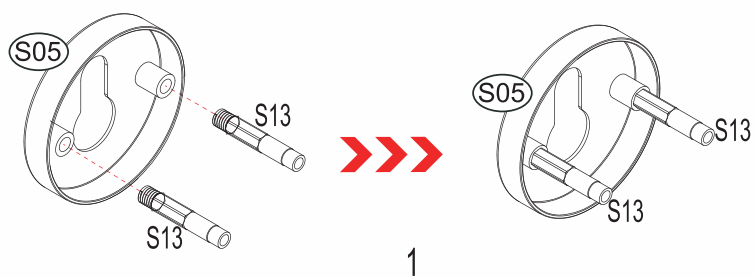

53

| Części  | Nr | Ilość |
|---|----|-------|
|  | F3 | 12    |

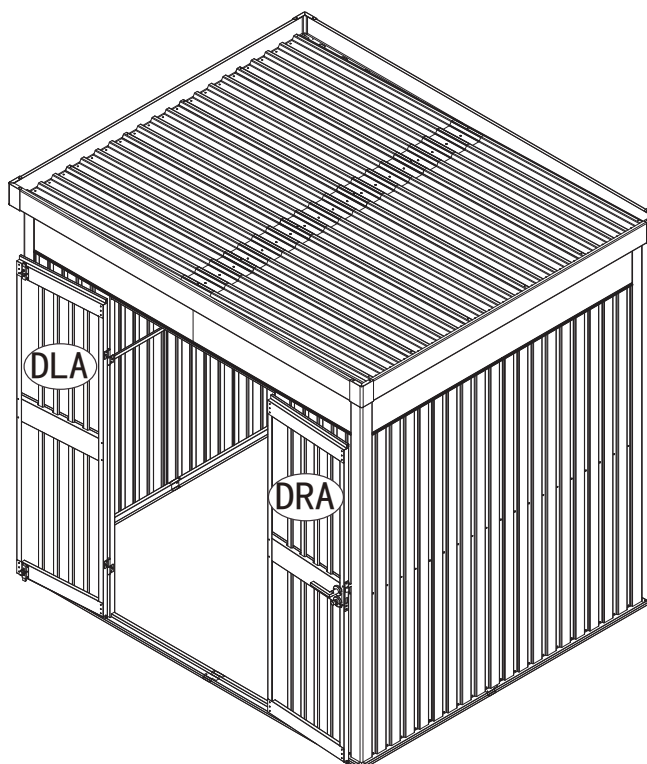
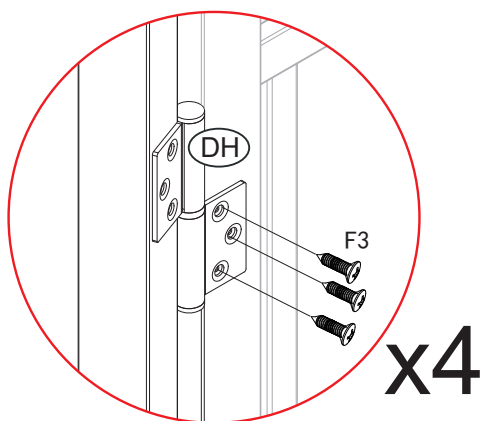

| Części  | Nr   | Ilość |
|---|------|-------|
|  | 6x80 | 8     |

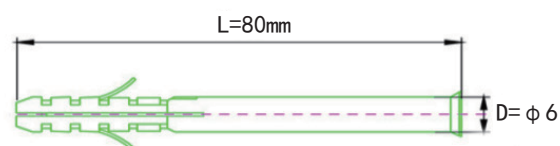
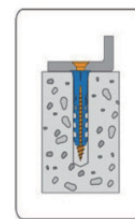
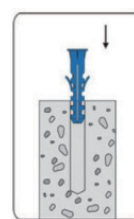
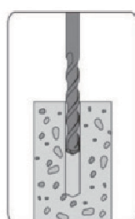
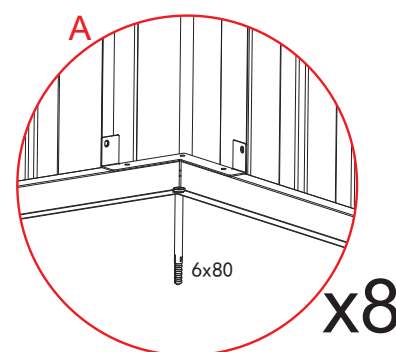
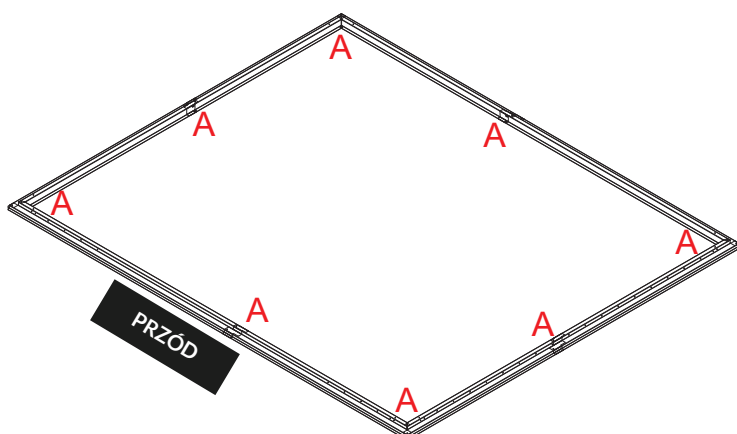

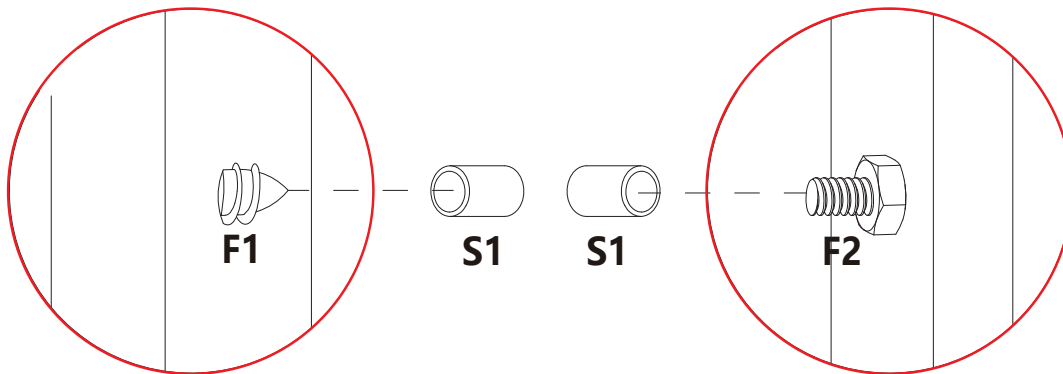

| Części  | Nr | Ilość |
|---|----|-------|
|  | S1 |       |

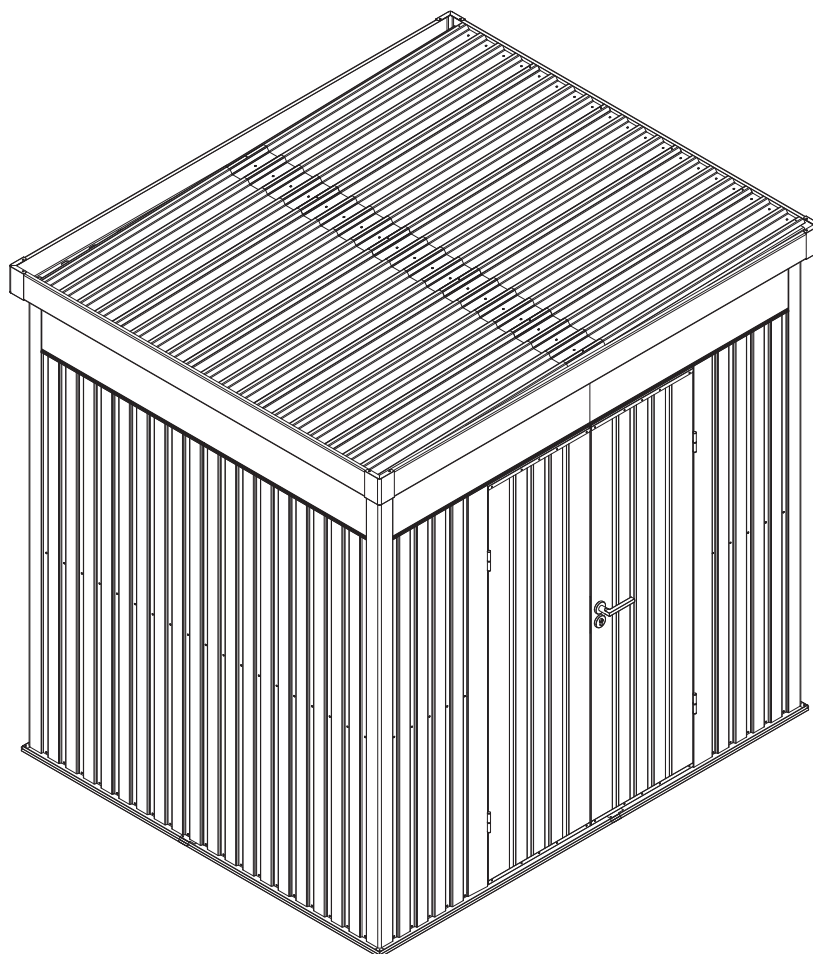

# INFORMACJE NA TEMAT UŻYTKOWANIA

**WAŻNE!** Zachować do późniejszego stosowania: uważnie przeczytać.

## Przeznaczenie

Domki narzędziowe do ogrodu to propozycja dla osób które chcą tanio i szybko postawić zadaszoną wiatę i z powodzeniem przechowywać w nich sprzęt ogrodowy, wszelkiego rodzaju narzędzia i maszyny. Domek przeznaczony wyłącznie do użytku na zewnątrz.

## Zasady użytkowania

Użytkowanie i montaż powinny odbywać się na suchym, twardym i równym podłożu. Zarówno montaż jak i konserwacja powinny być dokonywane wyłącznie przez osoby dorosłe. Do zmontowania tego modelu zalecany jest udział 2 dorosłych osób. Przed rozpoczęciem użytkowania, upewnij się, że cała konstrukcja jest stała i poprawnie zmontowana, a śruby dokręcone. Zaniechanie może doprowadzić do uszkodzenia elementów konstrukcji a w konsekwencji do wypadku i urazu użytkowników. Nie należy wspinać się na dach domku, gdyż upadek z tej wysokości grozi poważnymi urazami a w skrajnych przypadkach nawet śmiercią. Nigdy nie rozpalaj grilla wewnątrz domku, nie puszczaj fajerwerków ani innych akcesoriów z otwartym ogniem.

## Czyszczenie i konserwacja

**Wykończenie:** Aby uzyskać długotrwałe wykończenie, okresowo czyść i woskuj zewnętrzną powierzchnię.

Zadbaj o zadrapania, gdy tylko zauważysz je na swoim modelu. Natychmiast oczyść obszar za pomocą szczotki drucianej; umyj i nałóż farbę do naprawy zgodnie z zaleceniem producenta.

## Dach

Utrzymuj dach w czystości od liści i śniegu za pomocą długiej, miękkiej szczotki. Duże ilości śniegu na dachu mogą uszkodzić domek, przez co wejście do niego będzie niebezpieczne. W krajach z dużymi opadami śniegu, zestawy wzmacniające dach są dostępne dla większości budynków typu „Arrow”, co zapewnia dodatkową ochronę przed dużym gromadzeniem się śniegu.

## Drzwi

Zawsze utrzymuj prowadnice drzwi z dala od brudu i innych zanieczyszczeń, które uniemożliwiają ich łatwe przesuwanie. Co roku nasmaruj prowadnice drzwi za pomocą specjalnej pasty lub sprayu silikonowego. Staraj się trzymać drzwi zamknięte i zablokowane, aby zapobiec uszkodzeniom powodowanym przez wiatr.

## Elementy łączące

Użyj wszystkich dostarczonych podkładek, aby zabezpieczyć przed infiltracją pogody i aby zabezpieczyć metal przed porysowaniem śrubami. Regularnie sprawdzaj swój domek pod kątem poluzowanych śrub, nakrętek itd. i dokręć je w razie potrzeby.

## Wilgoć

Arkusze z tworzywa sztucznego (paroizolacja) umieszczone pod całą powierzchnią podłogi z dobrą wentylacją zredukują kondensację.

## Inne wskazówki

Zmyć numery części napisane tuszem na panelach mydłem i wodą. Uszczelnienia silikonowe mogą być stosowane do uszczelnień wodoszczelnych w całym domku. Nie przechowuj chemikaliów basenowych w swoim domku narzędziowym. Materiały palne i żrące muszą być przechowywane w hermetycznie zamkniętych pojemnikach.



**WARNING!** Read the instructions manual carefully before assembly. Ensure you are assembling the house according to this instruction manual. Ensure all parts are included in the contents of this packaging. To avoid injury, protective gloves are recommended during assembly.

## BEFORE YOU START ASSEMBLING

### User manual

Before starting the installation, check local building codes regarding foundations, location and other requirements. Study and understand this assembly manual. Important information and helpful tips will make your work easier and more enjoyable.

### Assembly instructions

The instructions in this manual contain all the relevant information for your model. Read the entire manual before you start, and follow the sequence of steps carefully during assembly to get the right results.

### List of parts

Make sure you have all the necessary parts for assembly. Separate the contents of the carton by part number while viewing the parts list. The first few steps show you how to connect related parts to create larger subassemblies for use later. Familiarize yourself with the equipment and fittings for easier use during assembly. They are packed in a cardboard box. Please note that additional items are provided for your convenience.

## PLAN AHEAD

### Observe the weather

Make sure it is dry on the day you install your shed. Do not try to assemble the shed on a windy day.

### Team work







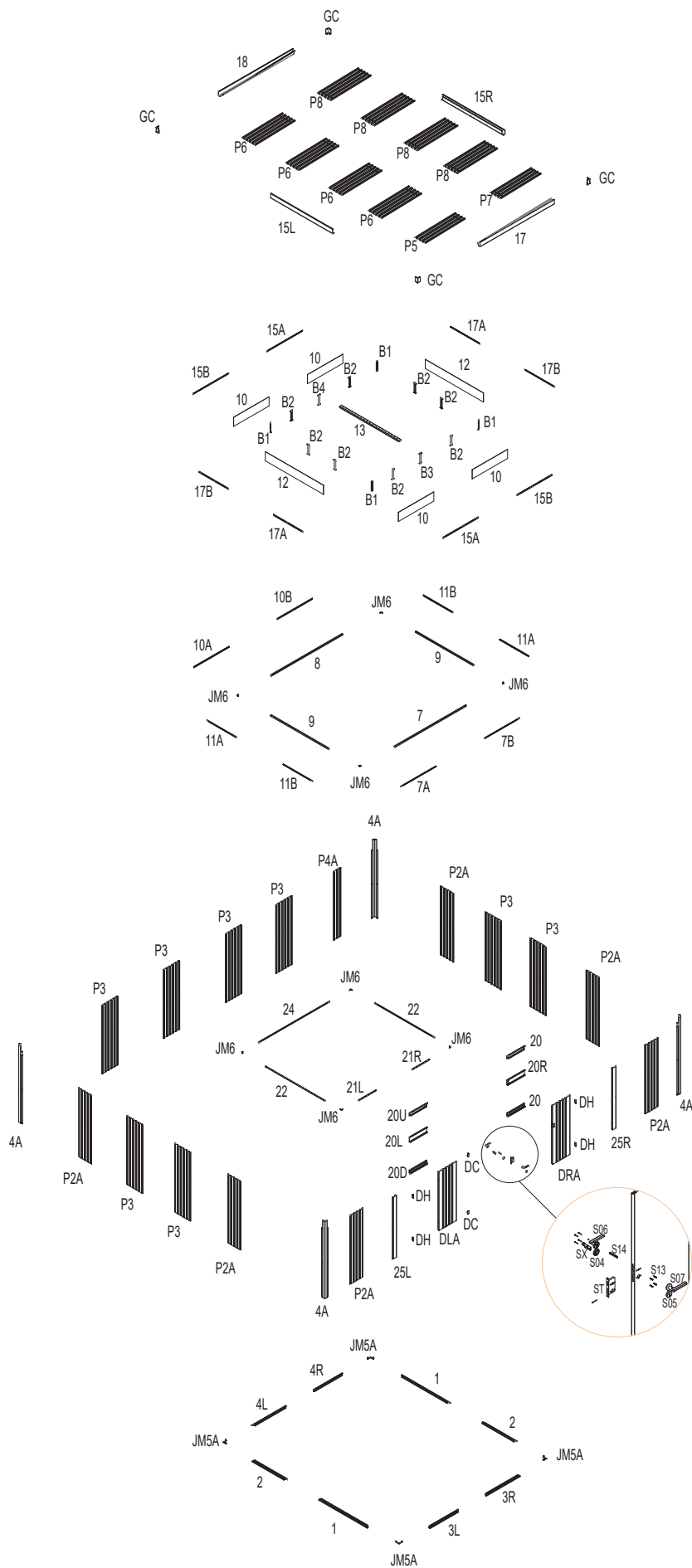



Whenever possible, two or more people should work together to assemble the shed. One person can position the parts or panels while the other is able to handle it with clasps and tools.





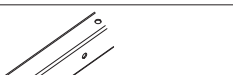
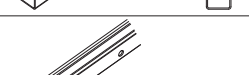
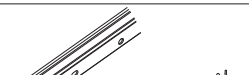

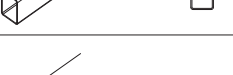

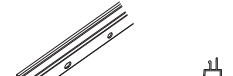
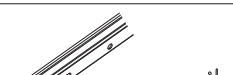
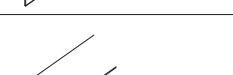
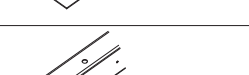

### Tools and equipment

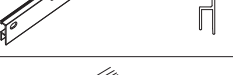
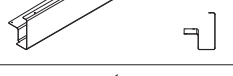
Only basic tools and materials are needed to build your shed. Select the anchoring method and the type of ground you want to use to create the complete list materials needed.









# PARTS LIST



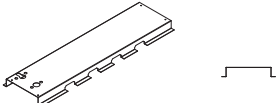

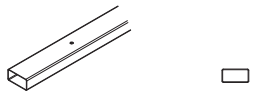
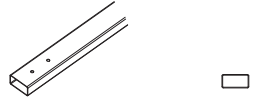
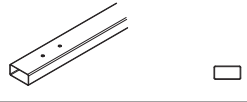
| NUMBER | DRAWING   | QTY |
|--------|---|-----|
| 1      |    | 2   |
| 2      |    | 2   |
| 3L     |    | 1   |
| 3R     |    | 1   |
| 4A     |    | 4   |
| 4L     |    | 1   |
| 4R     |  | 1   |
| 7      |  | 1   |
| 7A     |  | 1   |
| 7B     |  | 1   |
| 8      |  | 1   |
| 9      |  | 2   |
| 10     |  | 4   |
| 10A    |  | 1   |
| 10B    |  | 1   |

| NUMBER | DRAWING   | QTY |
|--------|---|-----|
| 11A    |    | 2   |
| 11B    |    | 2   |
| 12     |    | 2   |
| 13     |    | 1   |
| 15A    |    | 2   |
| 15B    |    | 2   |
| 15L    |   | 1   |
| 15R    |  | 1   |
| 17     |  | 1   |
| 17A    |  | 2   |
| 17B    |  | 2   |
| 18     |  | 1   |
| 20     |  | 2   |
| 20D    |  | 1   |
| 20L    |  | 1   |

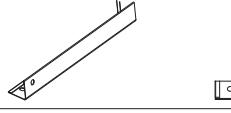
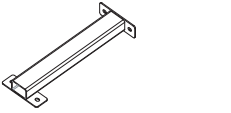
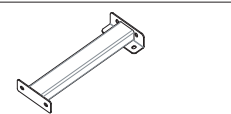
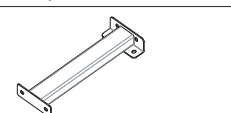
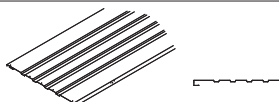
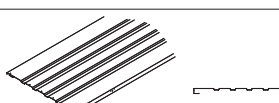
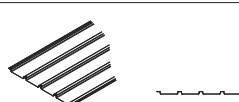

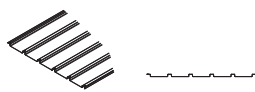
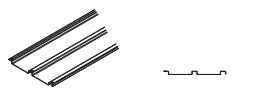

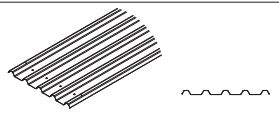
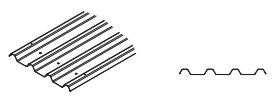
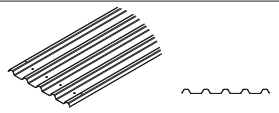
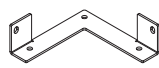
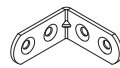
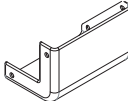
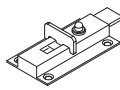
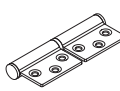

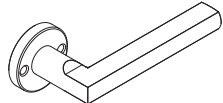
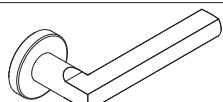



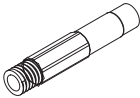
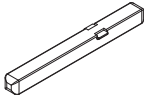
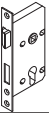
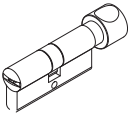

# PARTS LIST

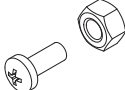

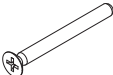
| NUMBER | DRAWING   | QTY |
|--------|---|-----|
| 20R    |    | 1   |
| 20U    |    | 1   |
| 21L    |    | 1   |
| 21R    |    | 1   |
| 22     |    | 2   |
| 24     |    | 1   |
| 25L    |  | 1   |
| 25R    |  | 1   |
| B1     |  | 4   |
| B2     |  | 8   |
| B3     |  | 1   |
| B4     |  | 1   |
| DLA    |  | 1   |
| DRA    |  | 1   |
| P2A    |  | 6   |

| NUMBER | DRAWING   | QTY |
|--------|---|-----|
| P3     |    | 8   |
| P4A    |    | 1   |
| P5     |    | 1   |
| P6     |    | 4   |
| P7     |    | 1   |
| P8     |    | 4   |
| JM5    |  | 4   |
| JM6    |  | 8   |
| GC     |  | 4   |
| DC     |  | 2   |
| DH     |  | 4   |
| S04    |  | 1   |
| S05    |  | 1   |
| S06    |  | 1   |
| S07    |  | 1   |



# PARTS LIST

| NUMBER | DRAWING   | QTY |
|--------|---|-----|
| S13    |    | 1   |
| S14    |    | 1   |
| ST     |    | 1   |
| SX     |    | 1   |
| F1     |    | 471 |
| S1     |    | 300 |
| S2     |  | 266 |
| F2     |  | 8   |
| F3     |  | 12  |
| M4X30  |  | 4   |
| M4X40  |  | 1   |
| M4X10  |  | 2   |
| F6     |  | 32  |
| 6*80   |  | 8   |

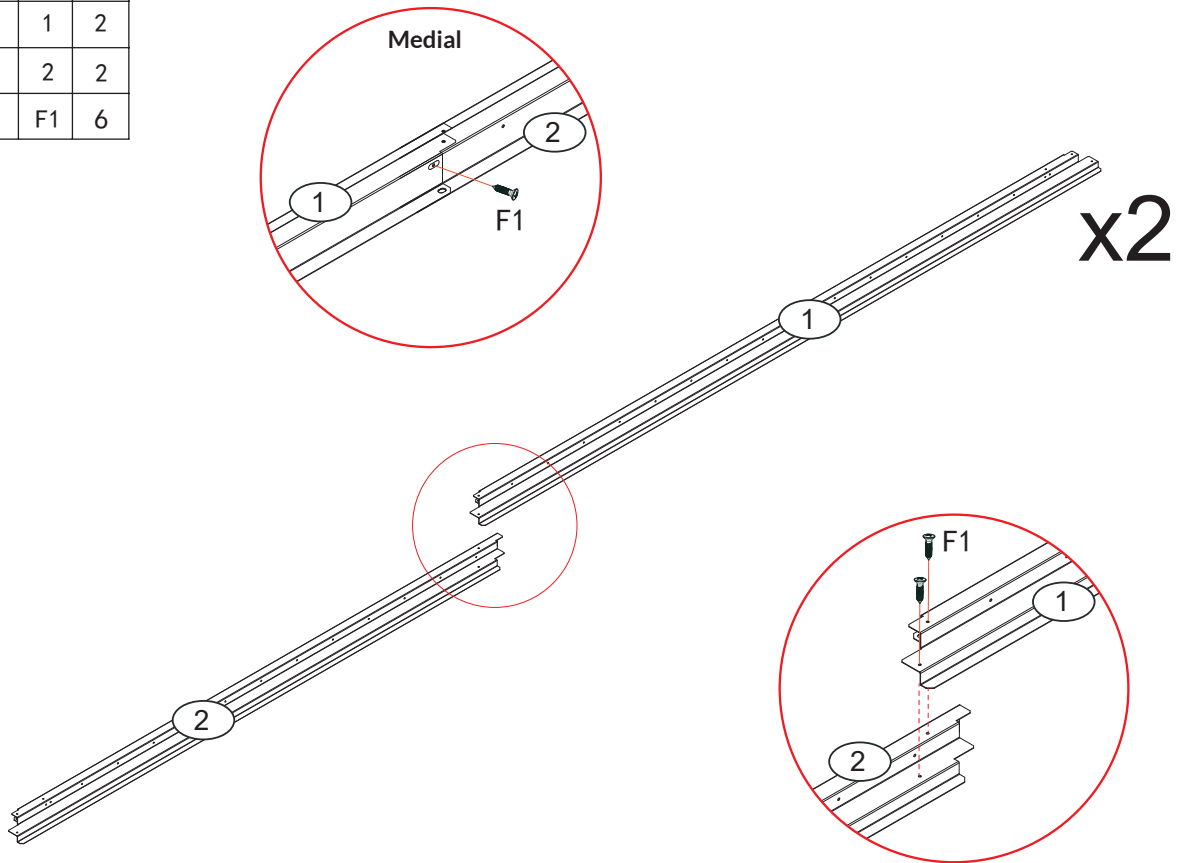

# ASSEMBLY

| Parts   | No | Qty |
|---|----|-----|
|  | 1  | 2   |
|  | 2  | 2   |
|  | F1 | 6   |

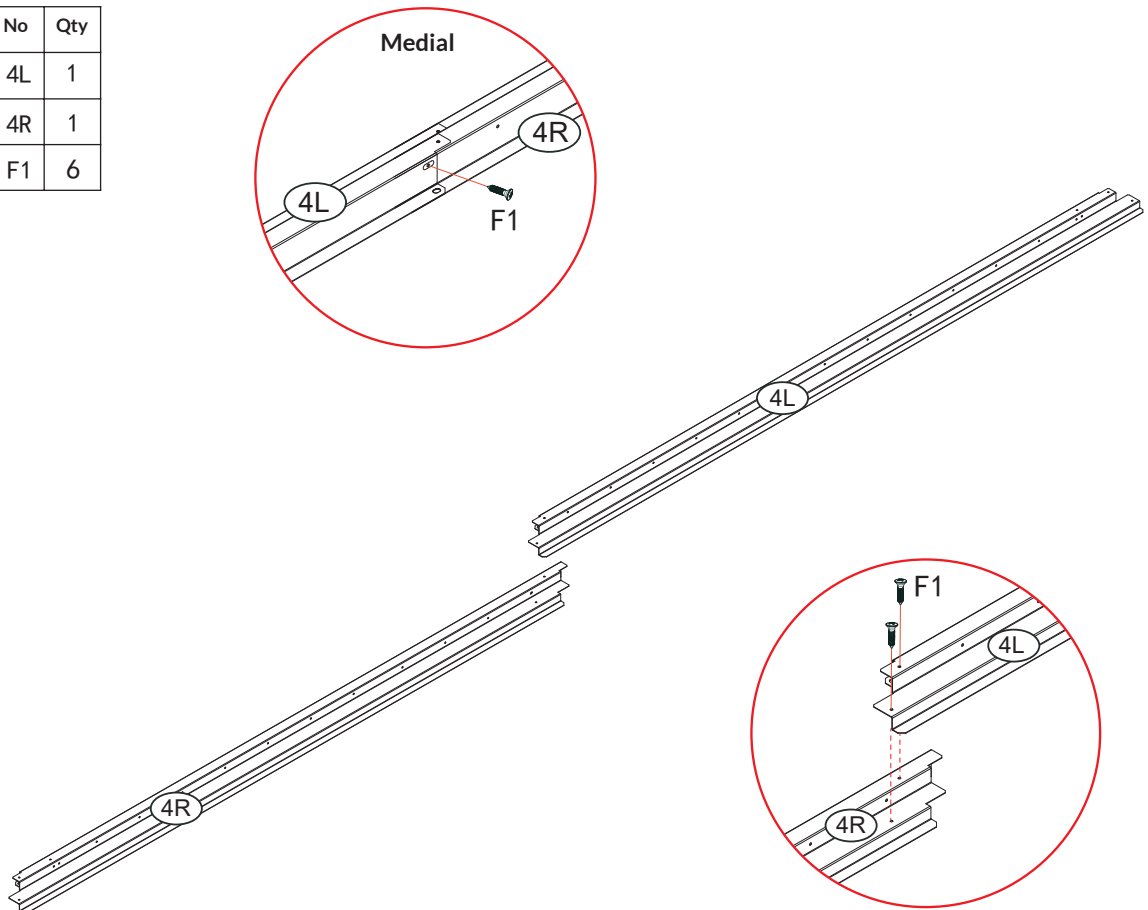

| Parts   | No | Qty |
|---|----|-----|
|  | 4L | 1   |
|  | 4R | 1   |
|  | F1 | 6   |





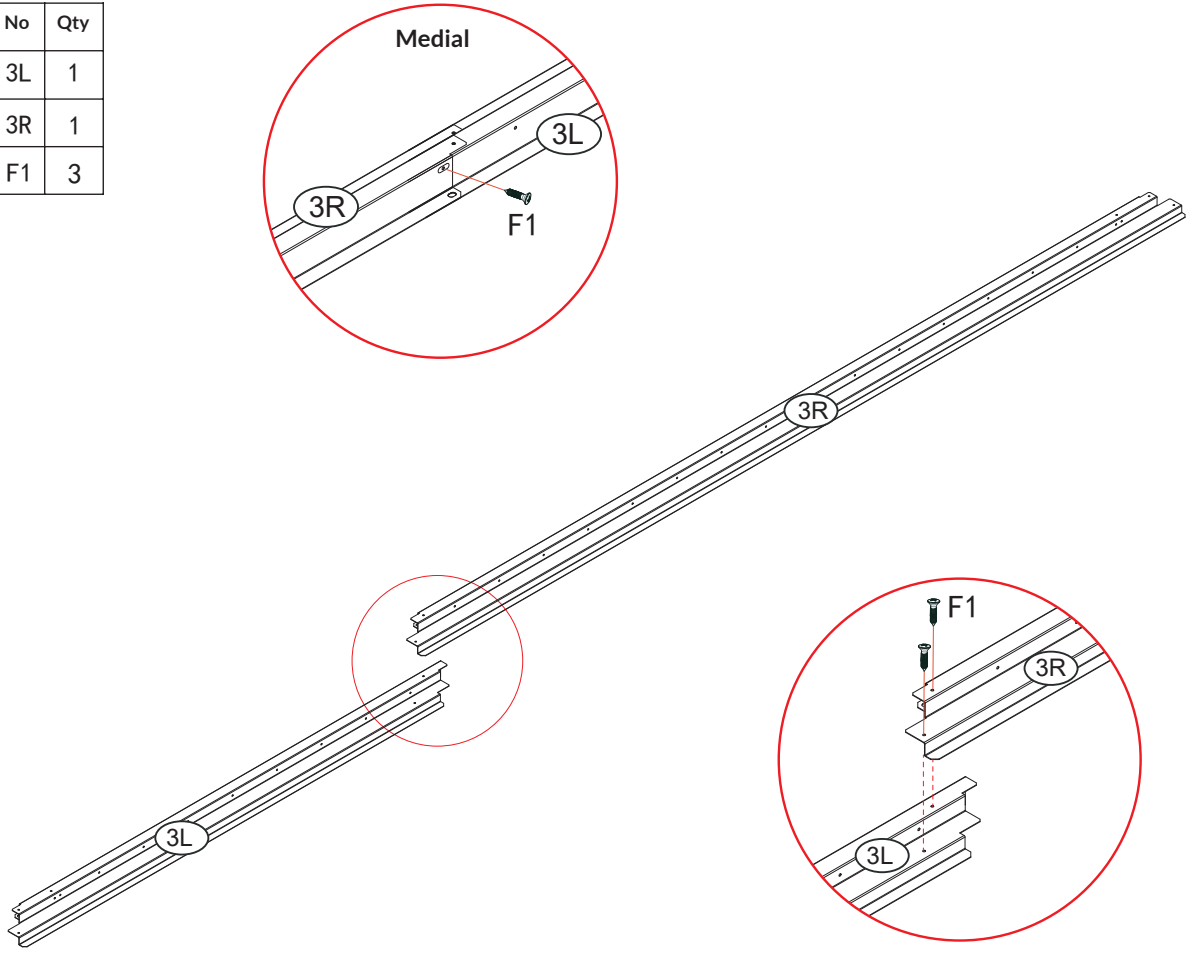

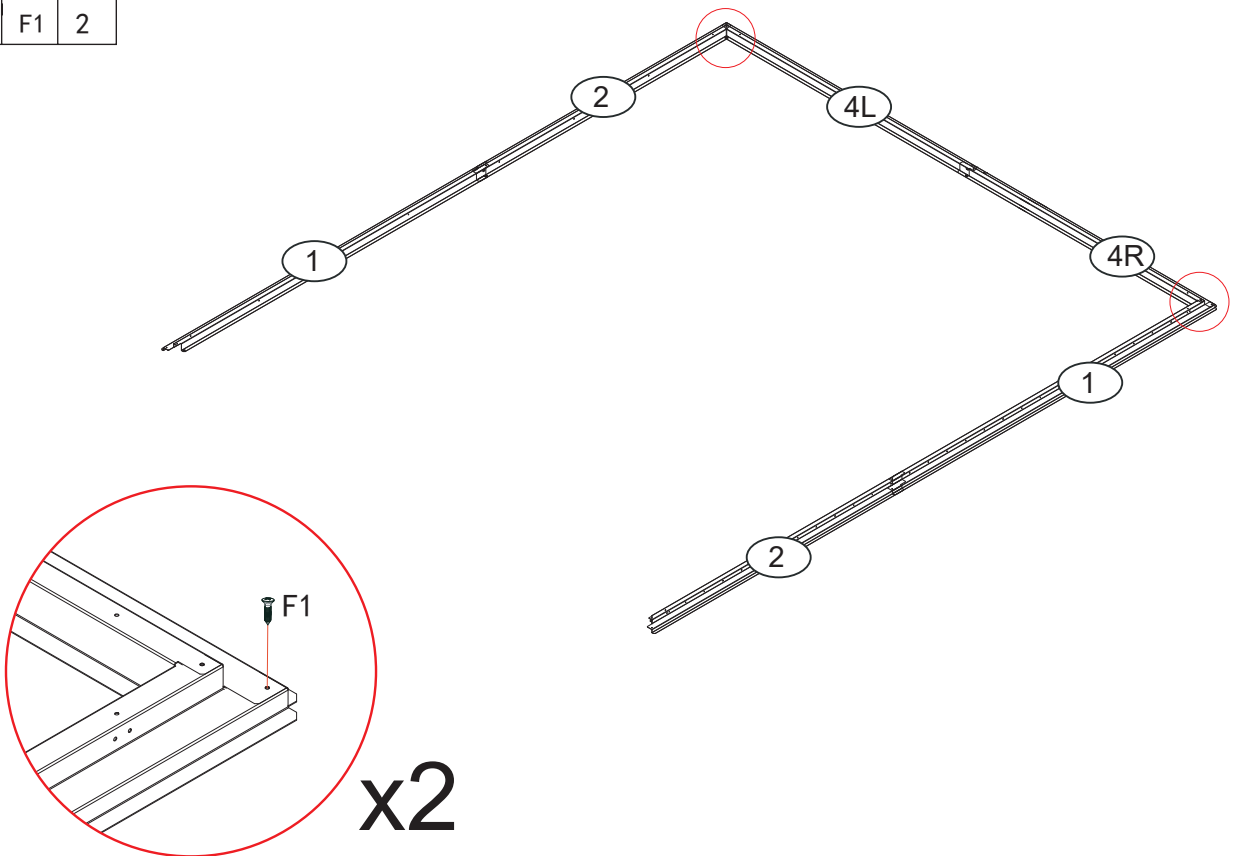

| Parts  | No | Qty |
|--|----|-----|
|  3L | 3L | 1   |
|  3R | 3R | 1   |
|  F1 | F1 | 3   |







| Parts  | No | Qty |
|--|----|-----|
|  F1 | F1 | 2   |

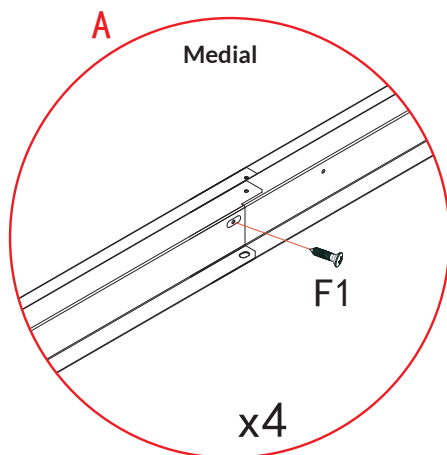
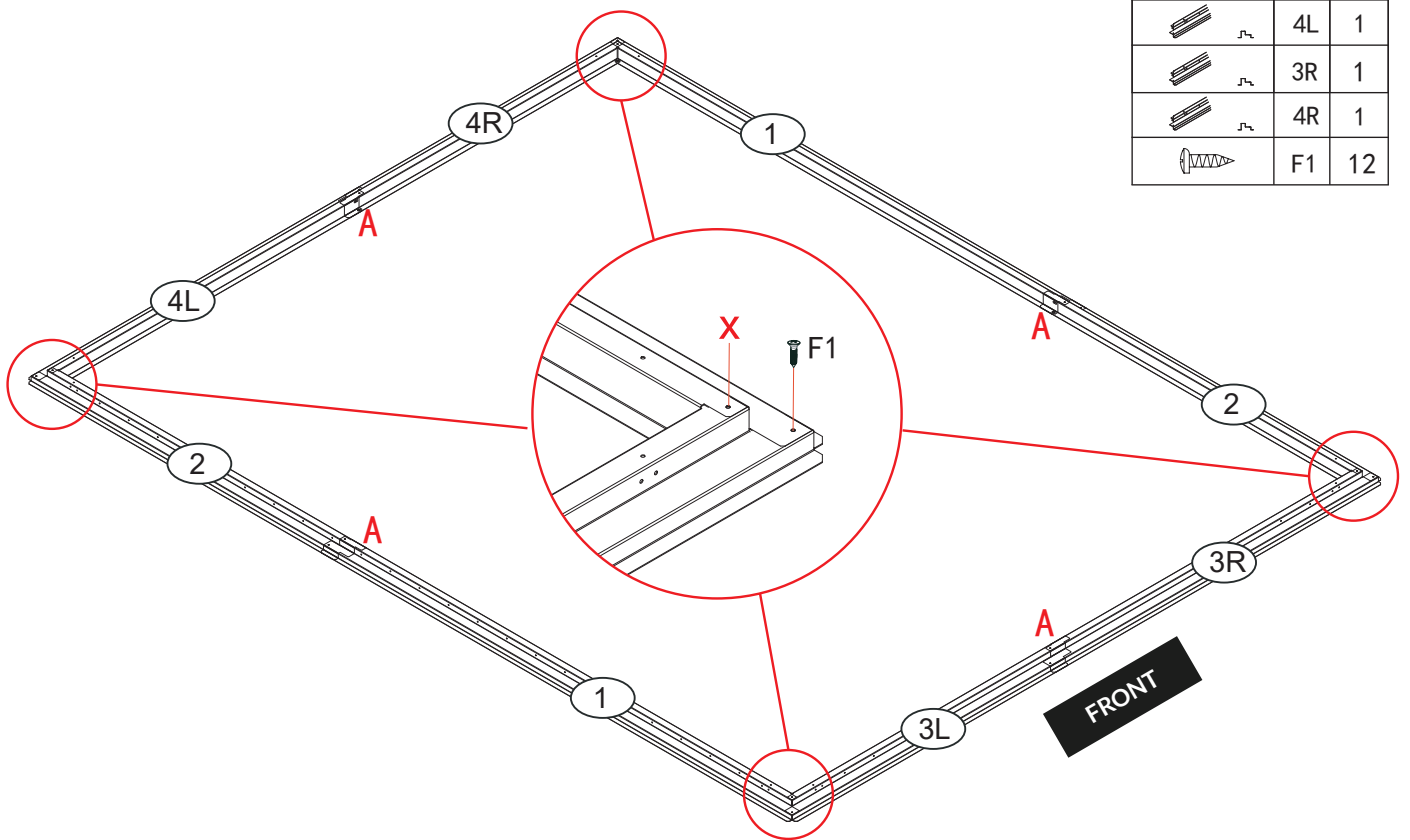

| Parts   | No | Qty |
|---|----|-----|
|  | 1  | 1   |
|  | 2  | 1   |
|  | 3L | 1   |
|  | 4L | 1   |
|  | 3R | 1   |
|  | 4R | 1   |
|  | F1 | 12  |



| Parts   | No   | Qty |
|---|------|-----|
|  | JM5A | 4   |
|  | 4A   | 4   |
|  | F1   | 20  |
|  | F2   | 8   |

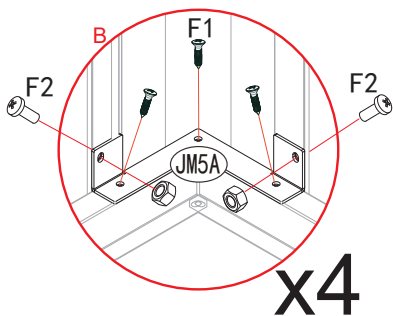

x4

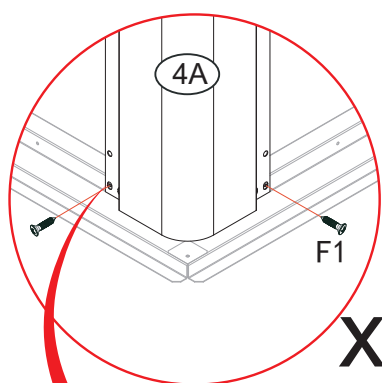
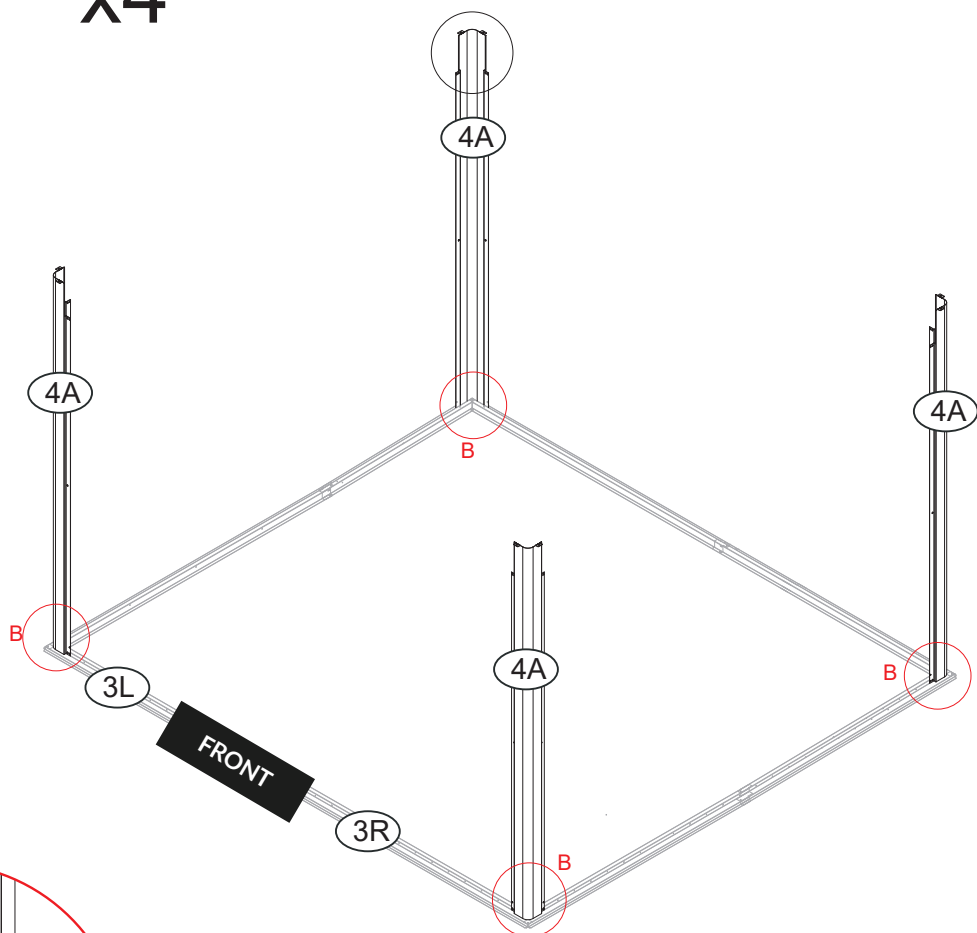

x4

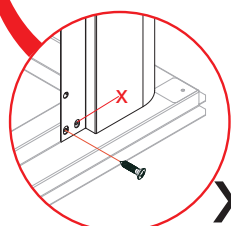



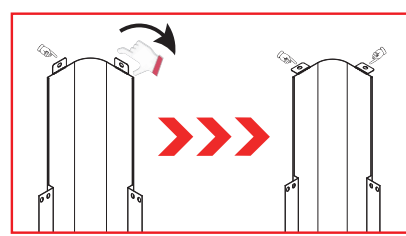

x8





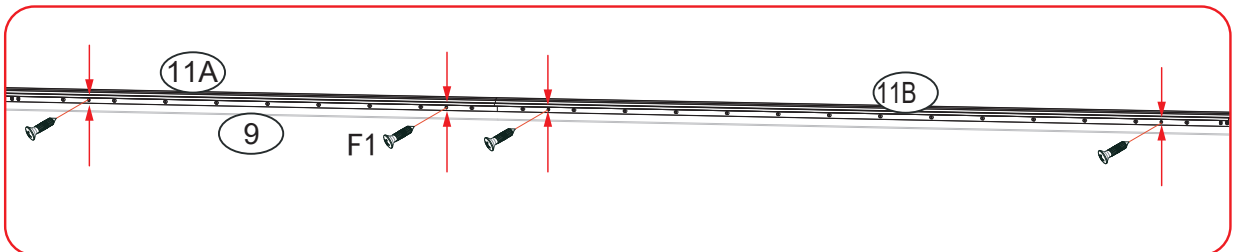
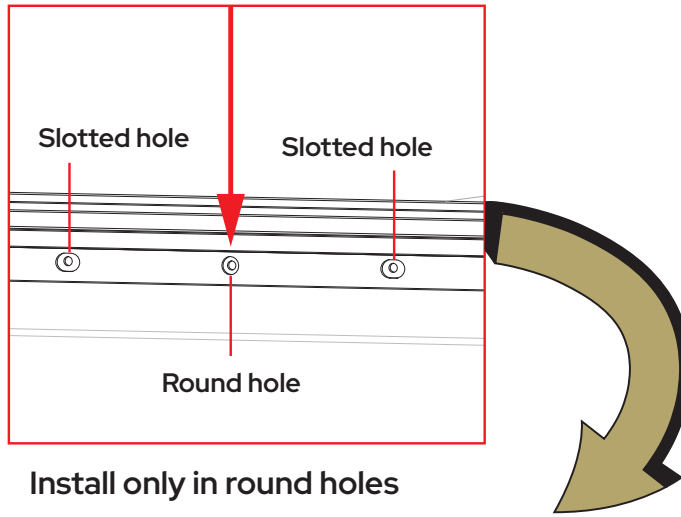
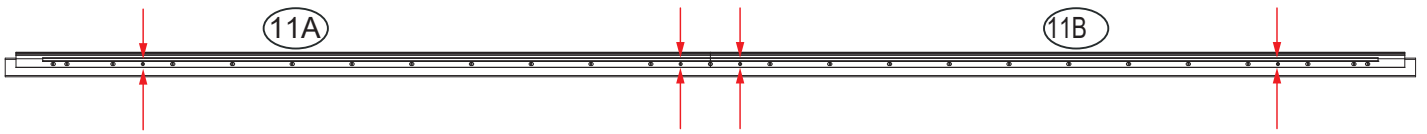
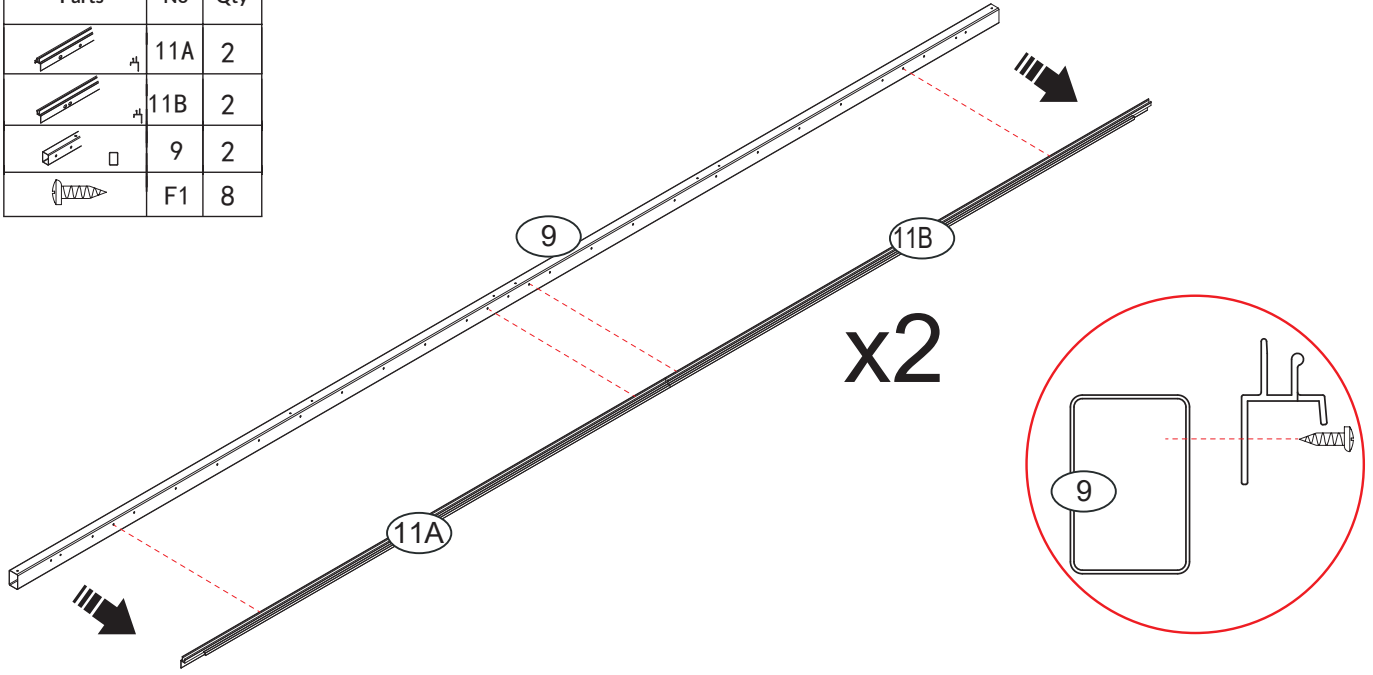

Bend manually at a 90° angle

Note: Screws must be installed only in the shown positions – other holes are not for mounting.

| Parts   | No  | Qty |
|---|-----|-----|
|  | 11A | 2   |
|  | 11B | 2   |
|  | 9   | 2   |
|  | F1  | 8   |





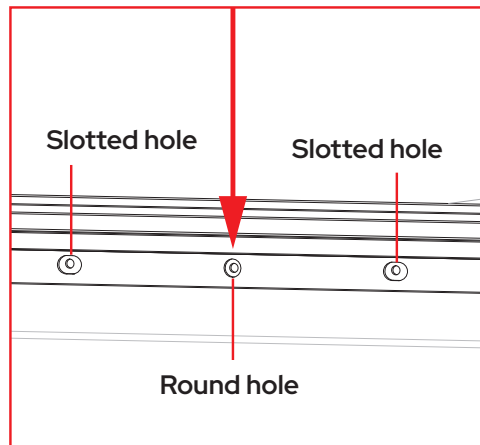
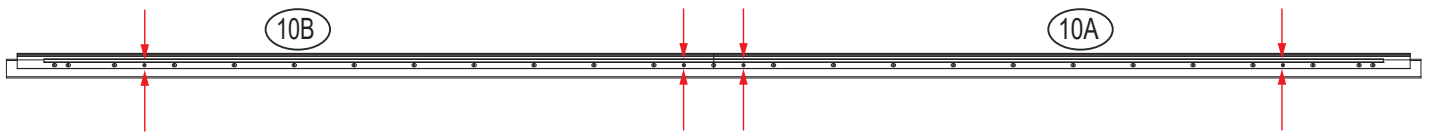
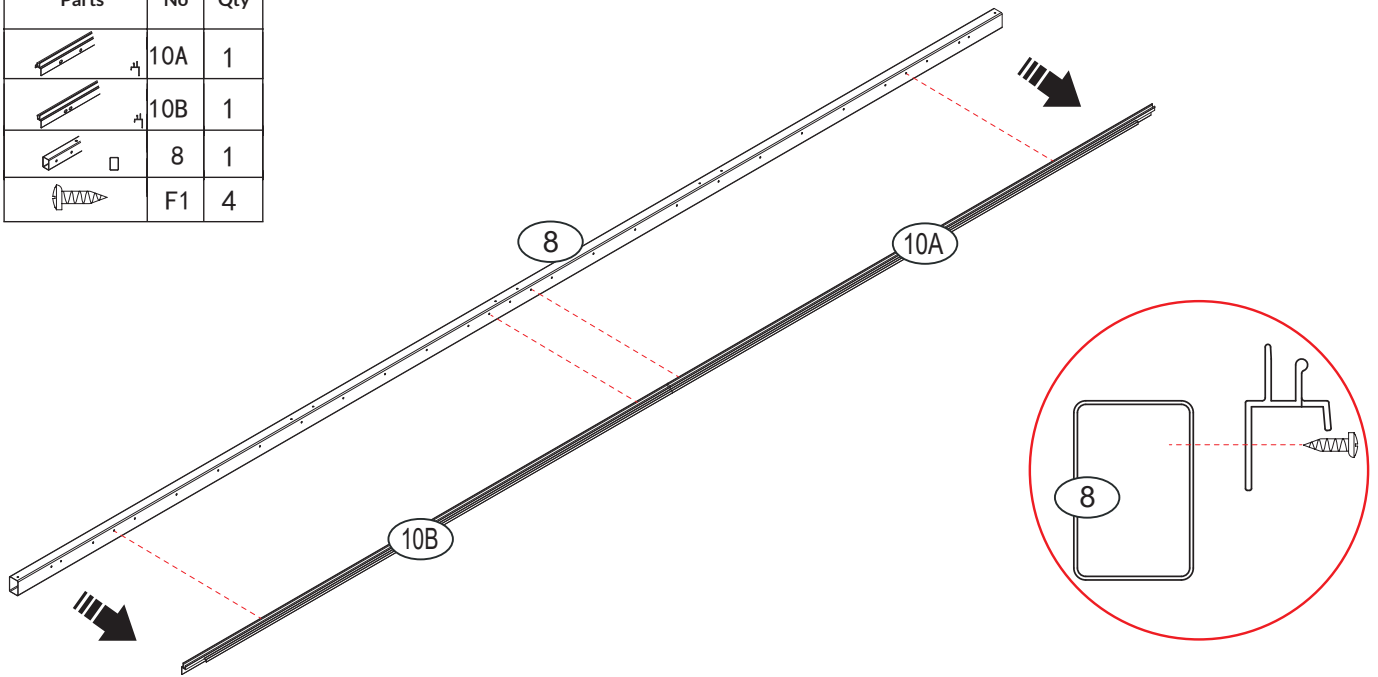

| Parts   | No  | Qty |
|---|-----|-----|
|  | 10A | 1   |
|  | 10B | 1   |
|  | 8   | 1   |
|  | F1  | 4   |

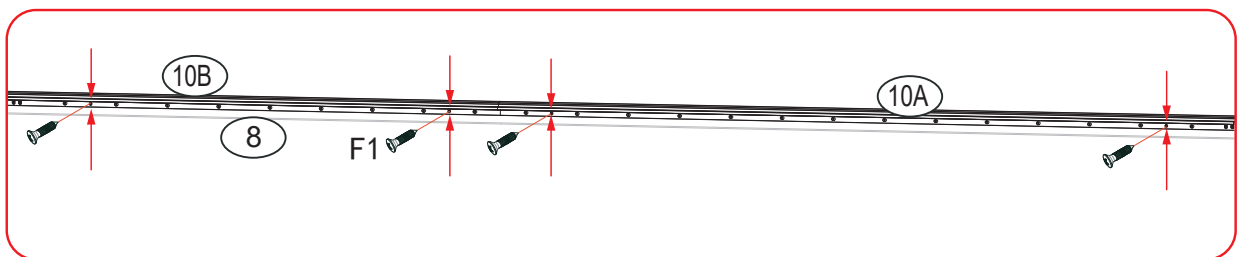

Install only in round holes





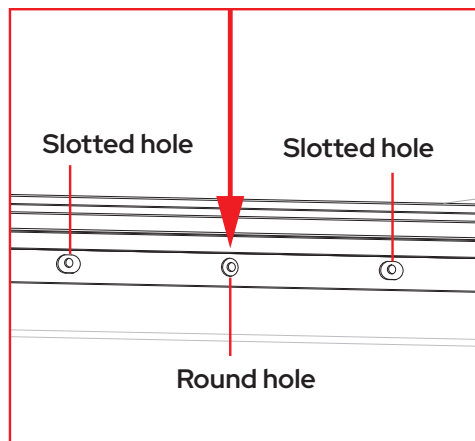
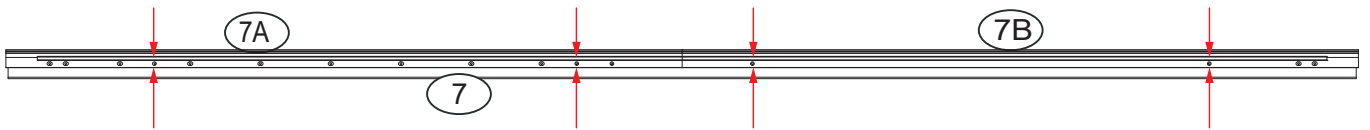
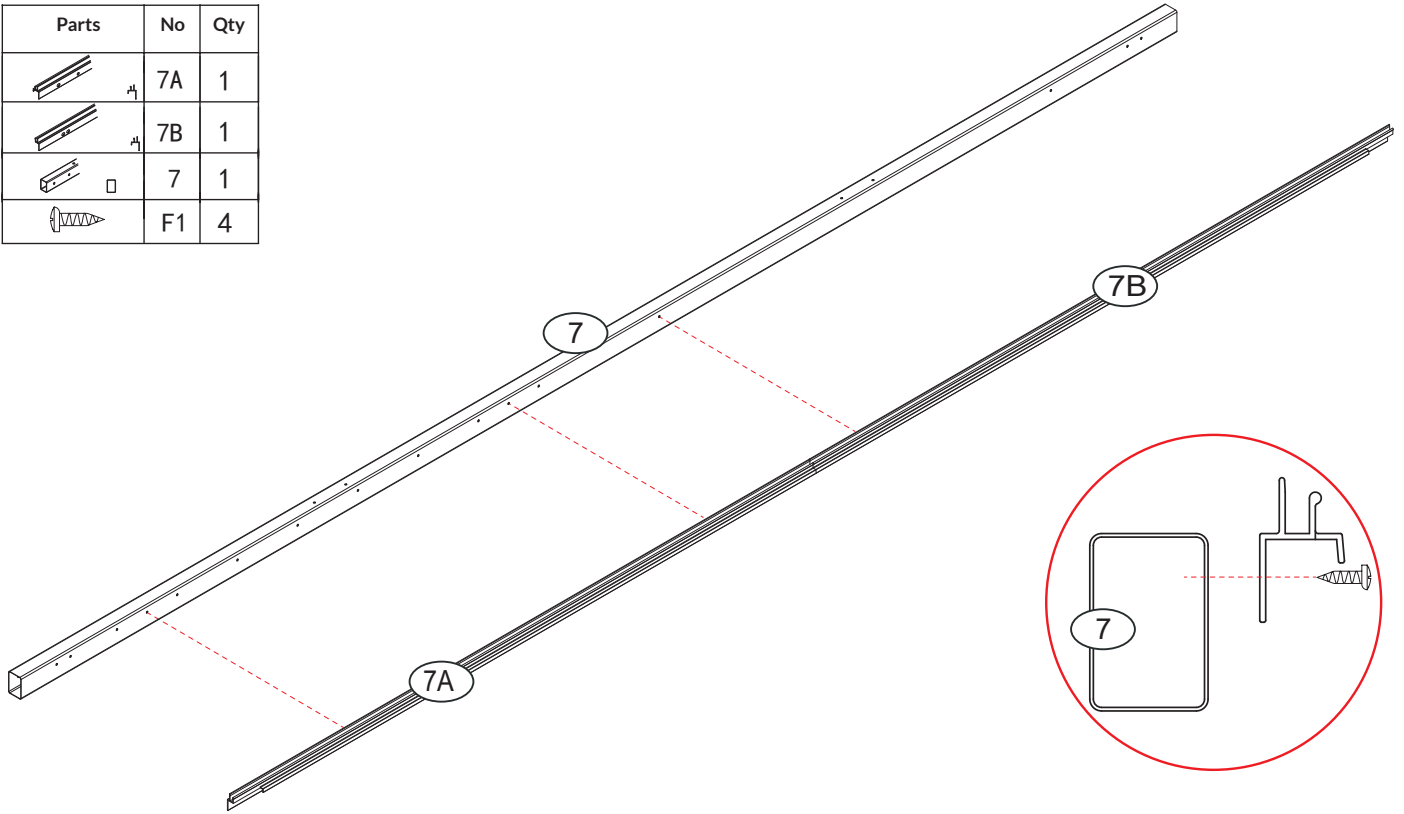

| Parts   | No | Qty |
|---|----|-----|
|  | 7A | 1   |
|  | 7B | 1   |
|  | 7  | 1   |
|  | F1 | 4   |

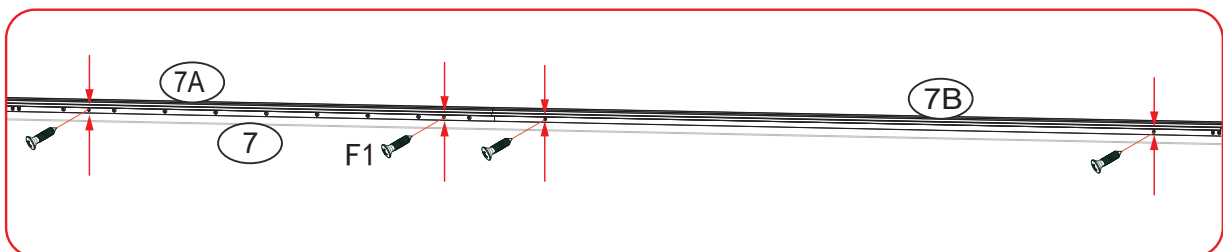

Install only in round holes



| Parts   | No | Qty |
|---|----|-----|
|  | F1 | 8   |

7, 8, 9 – One side of the structure should face outward.

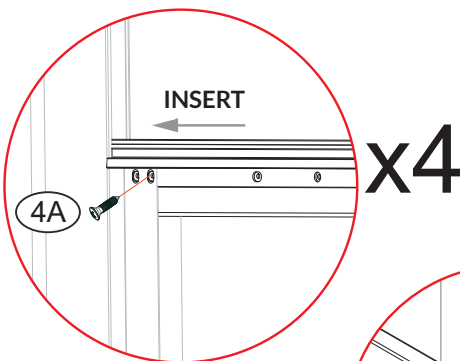
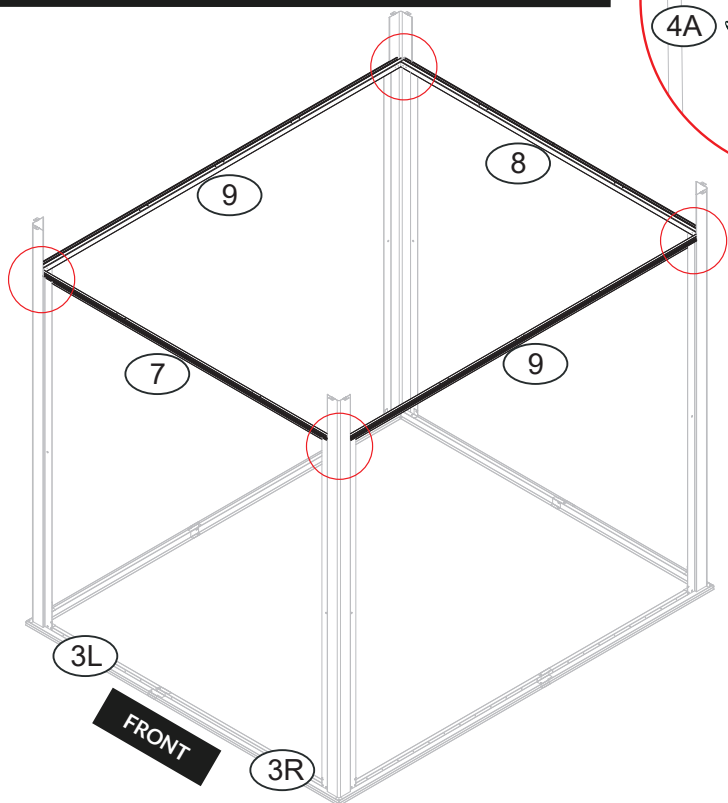

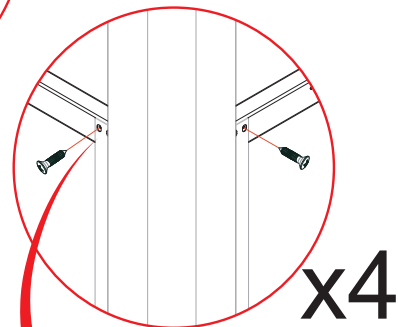

x4

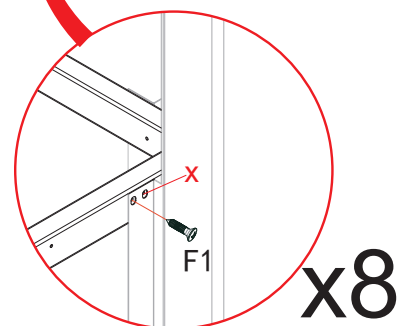

x4



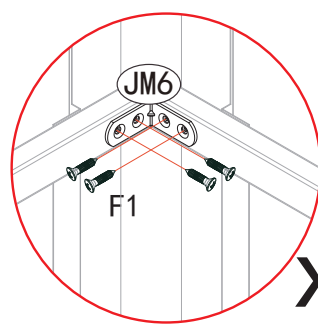
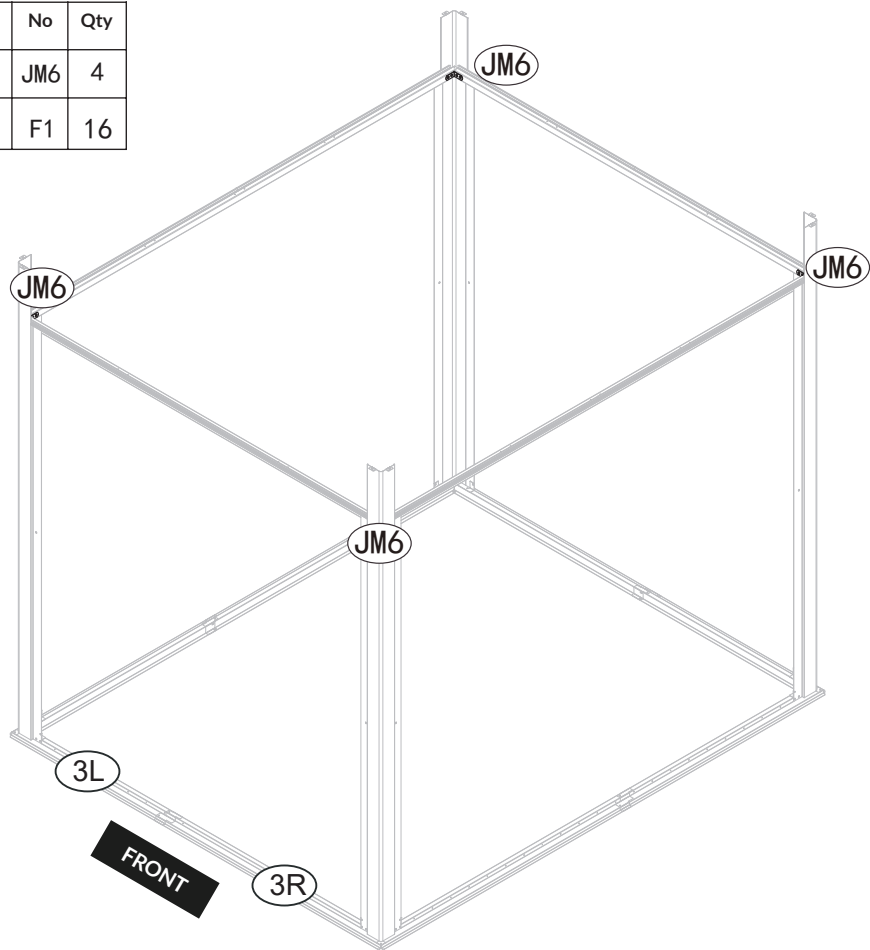

x8

| Parts   | No  | Qty |
|---|-----|-----|
|  | JM6 | 4   |
|  | F1  | 16  |



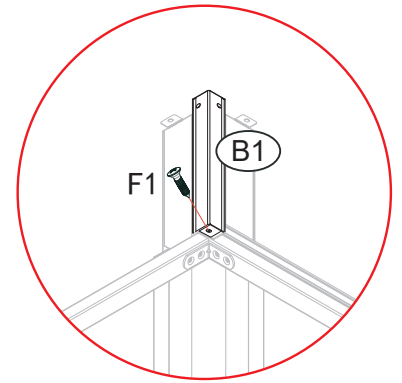
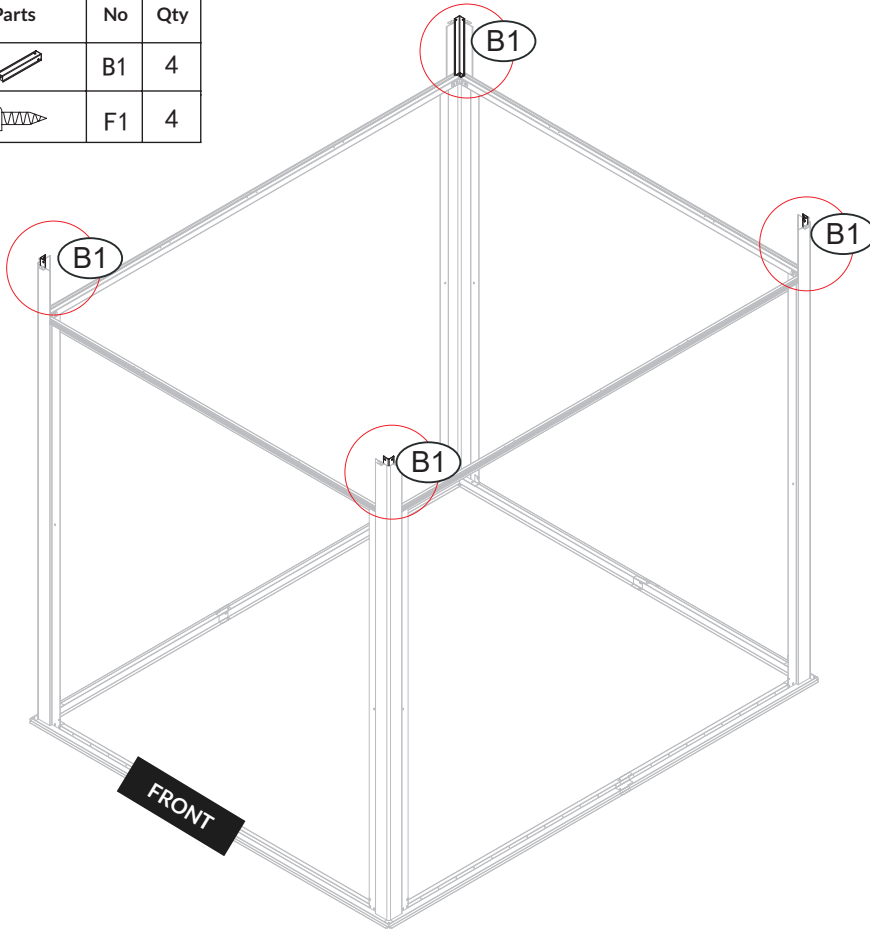

x4

| Parts   | No | Qty |
|---|----|-----|
|  | B1 | 4   |
|  | F1 | 4   |



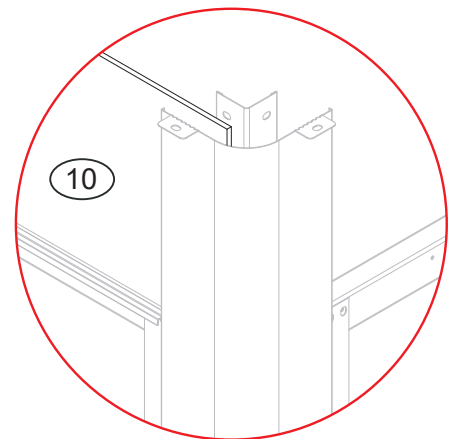
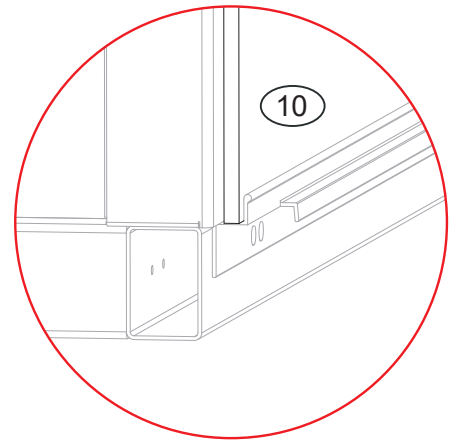
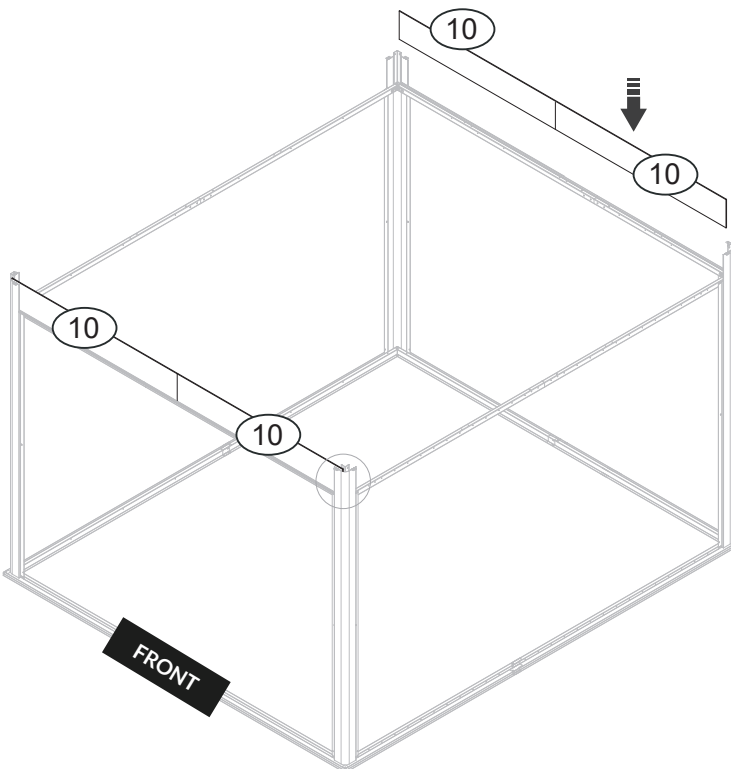



| Parts   | No | Qty |
|---|----|-----|
|  | 10 | 4   |

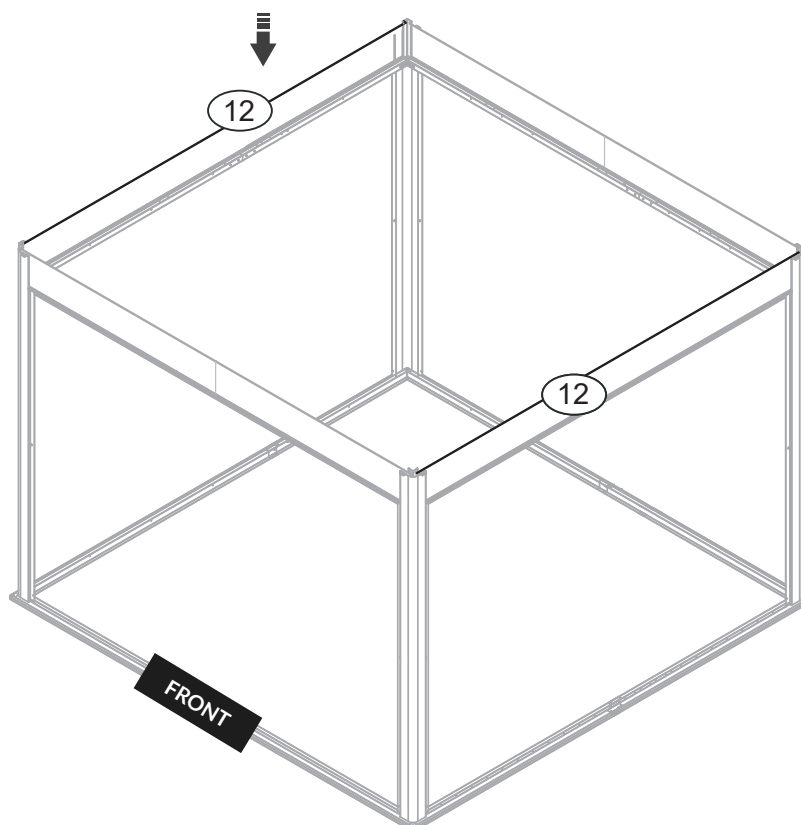
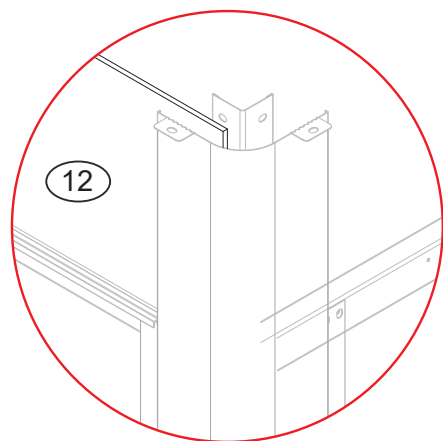
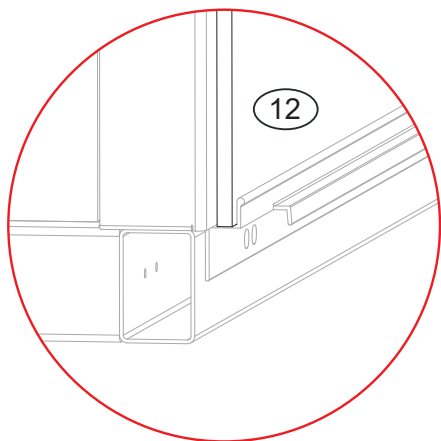

| Parts   | No | Qty |
|---|----|-----|
|  | 12 | 2   |





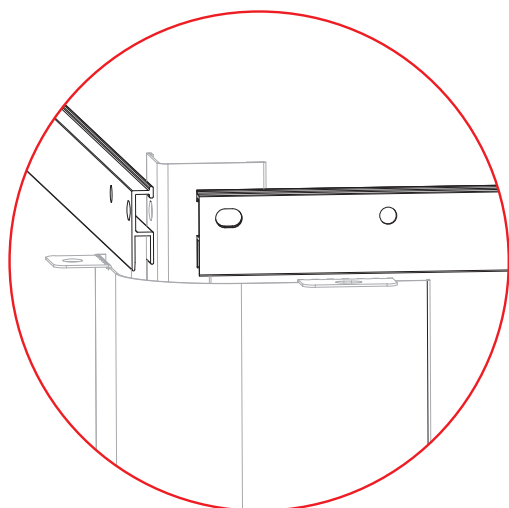
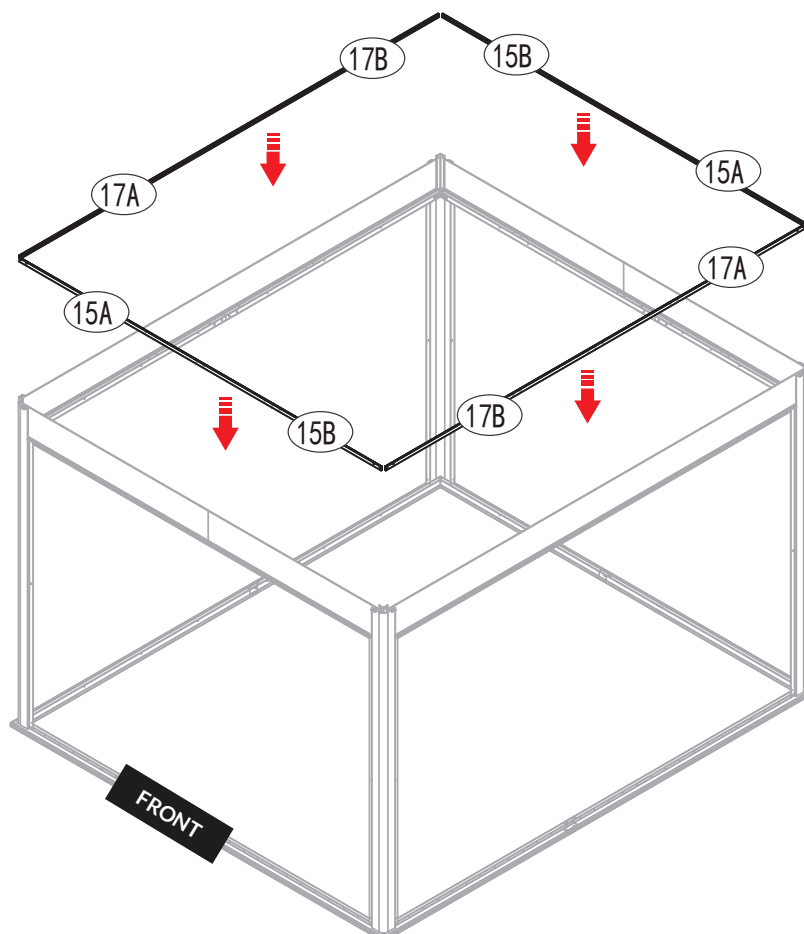

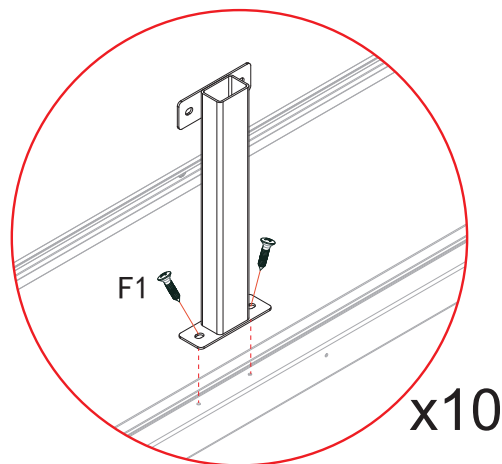
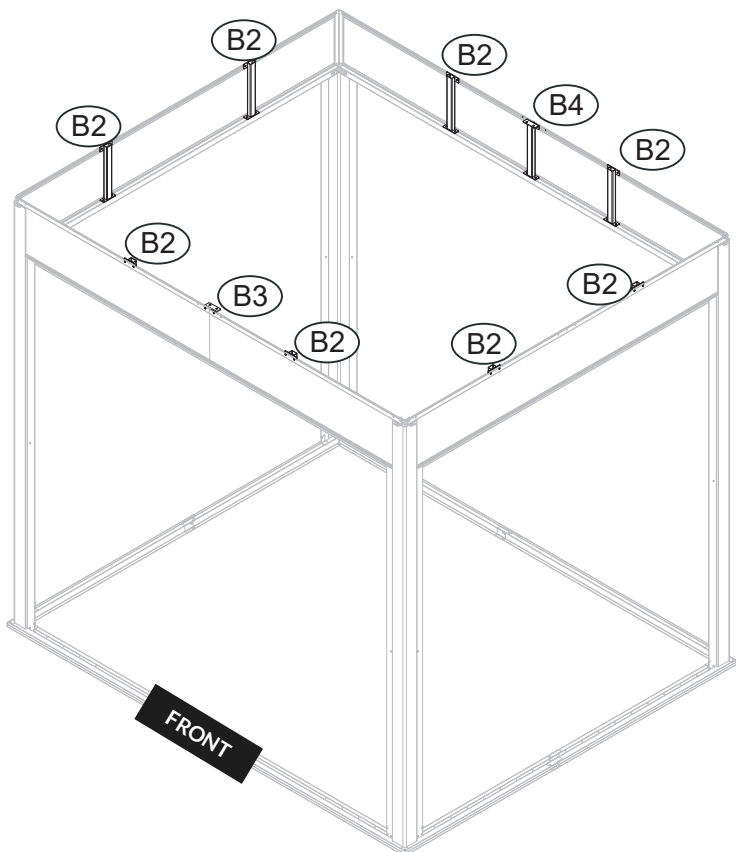
| Parts   | No  | Qty |
|---|-----|-----|
|  | 15A | 2   |
|  | 15B | 2   |
|  | 17A | 2   |
|  | 17B | 2   |









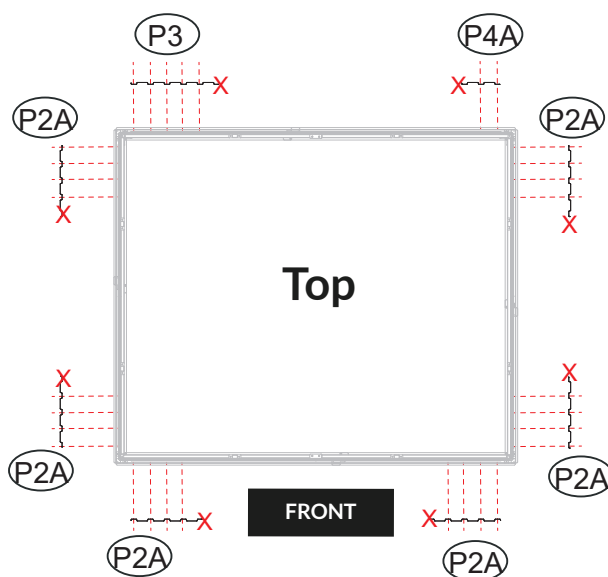
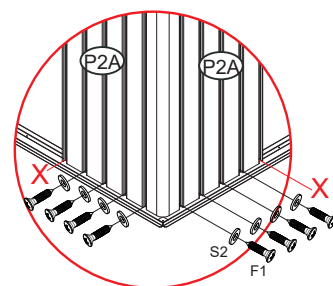
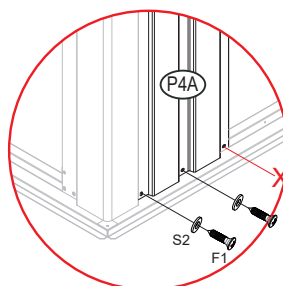
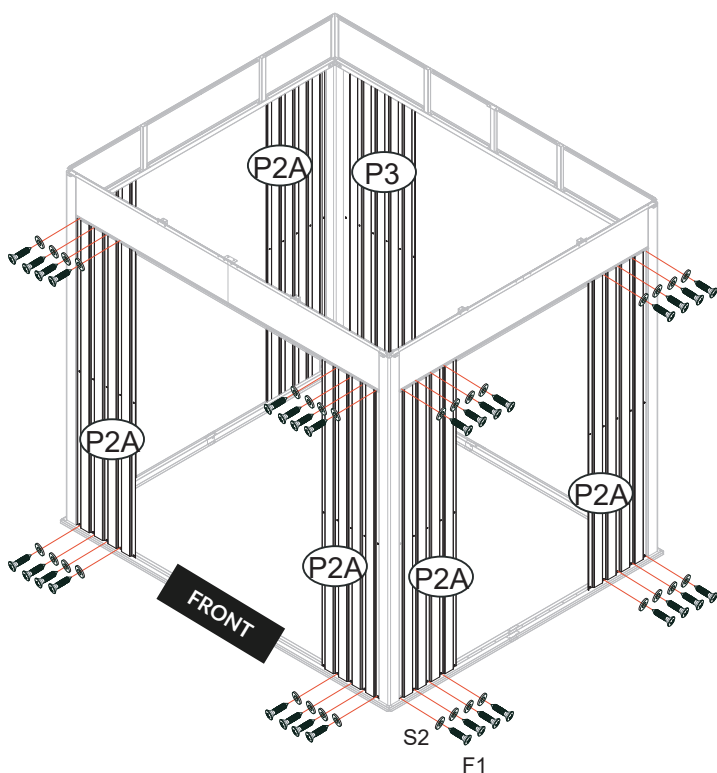



x10



| Parts  | No | Qty |
|--|----|-----|
|   | B2 | 8   |
|   | B3 | 1   |
|   | B4 | 1   |
|  | F1 | 20  |





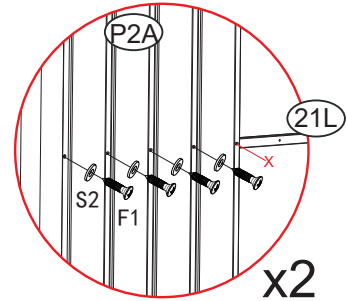
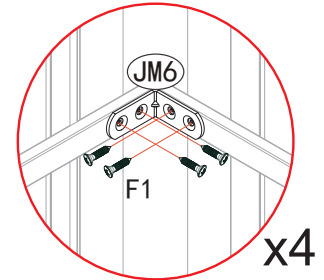
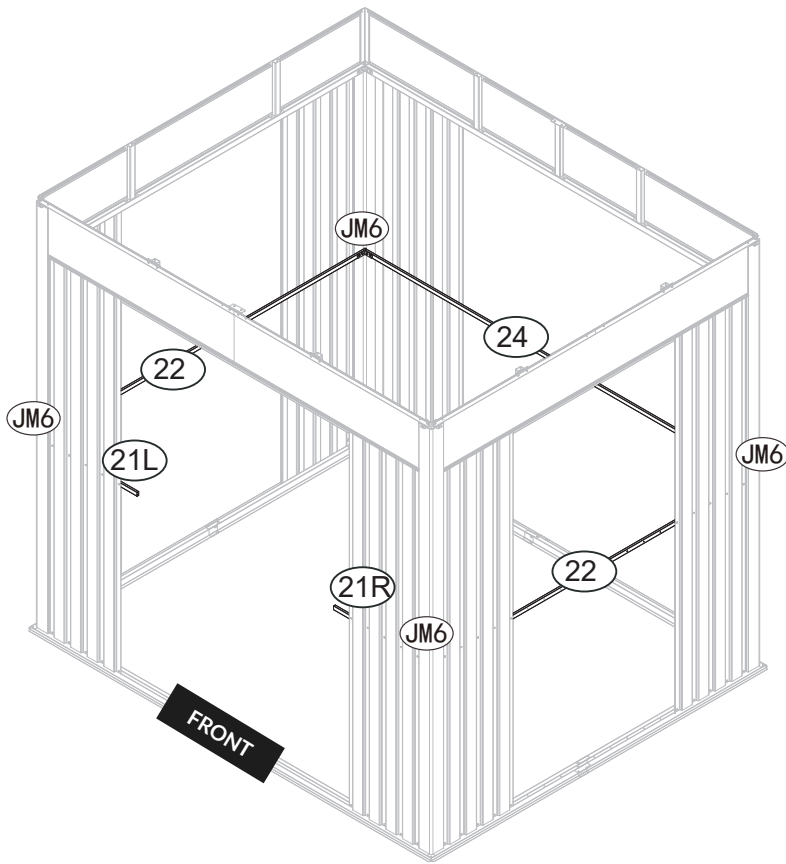

| Parts   | No | Qty |
|---|----|-----|
|  | F1 | 60  |
|  | S2 | 60  |

| Parts   | No  | Qty |
|---|-----|-----|
|  | JM6 | 4   |
|  | 21L | 1   |
|  | 22  | 2   |
|  | 21R | 1   |
|  | 24  | 1   |
|  | F1  | 47  |
|  | S2  | 31  |

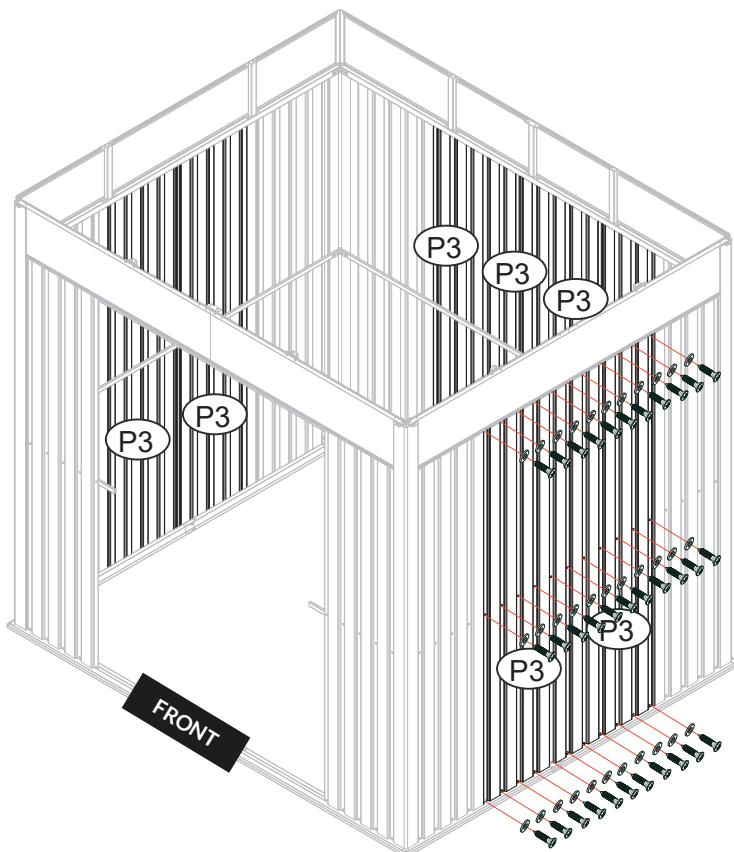



| Parts   | No | Qty |
|---|----|-----|
|  | P3 | 7   |
|  | F1 | 100 |
|  | S2 | 100 |

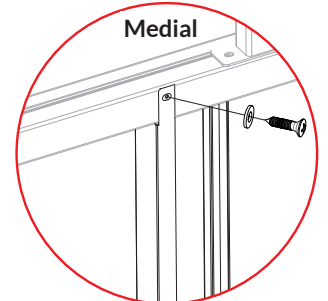
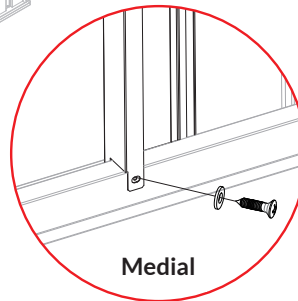
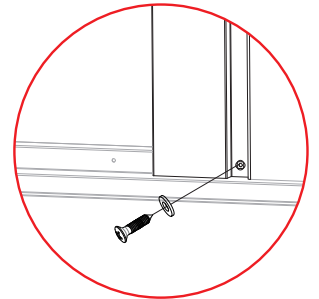
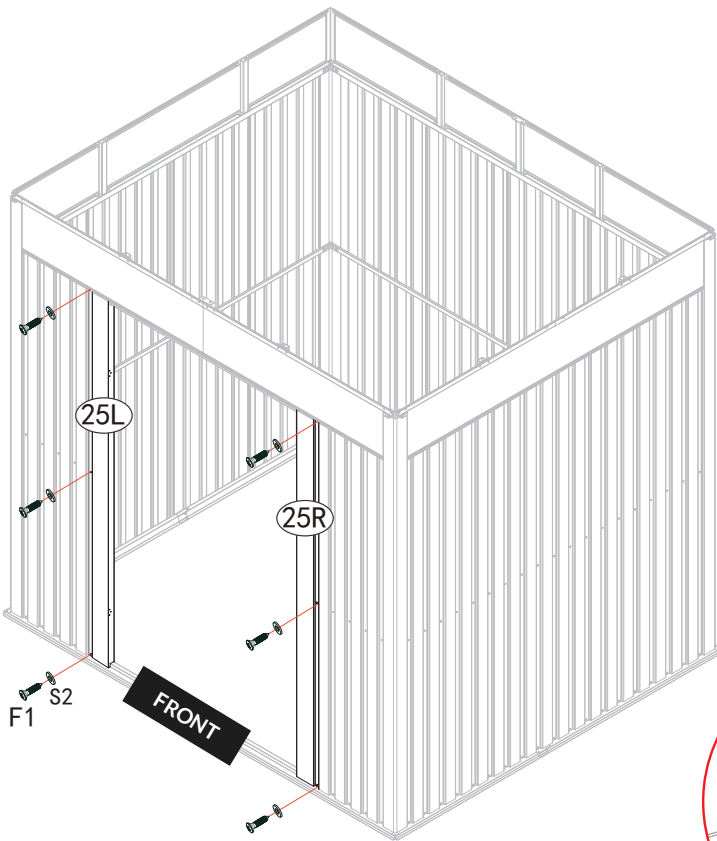

| Parts   | No  | Qty |
|---|-----|-----|
|  | 25L | 1   |
|  | 25R | 1   |
|  | F1  | 10  |
|  | S2  | 10  |



| Parts   | No | Qty |
|---|----|-----|
|  | 13 | 1   |
|  | F1 | 4   |

Note: Check the hole positions on part No. 13.

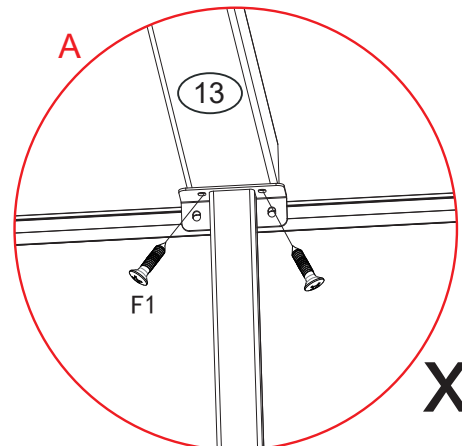
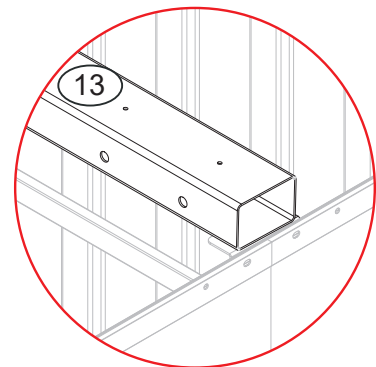
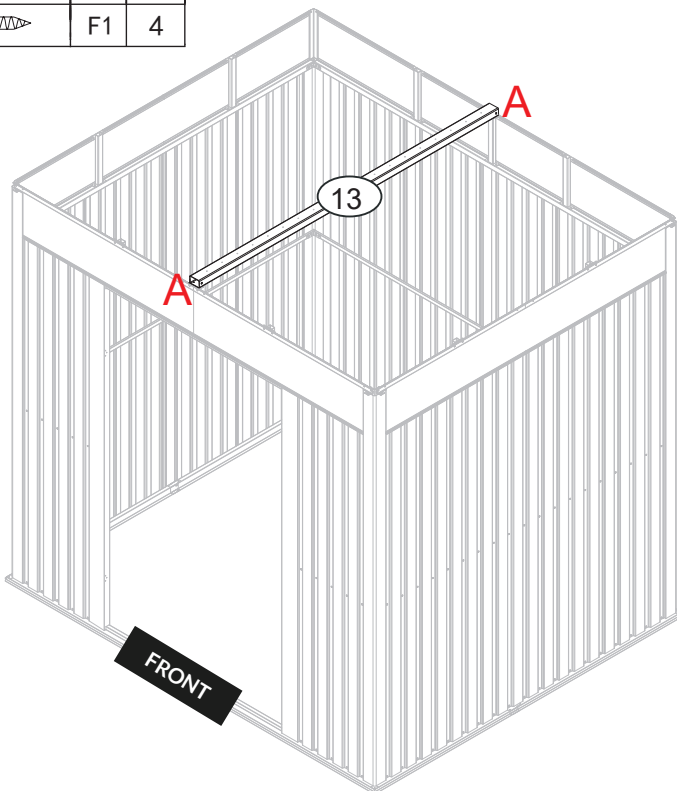

x2

Assembly of 15L and 15R is done the same way.

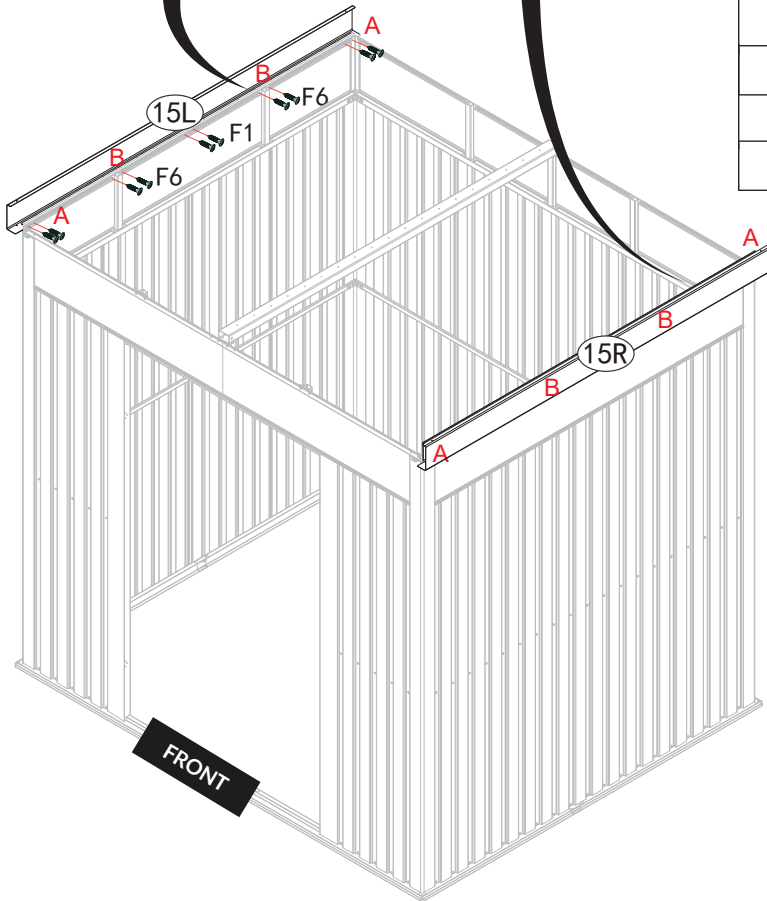



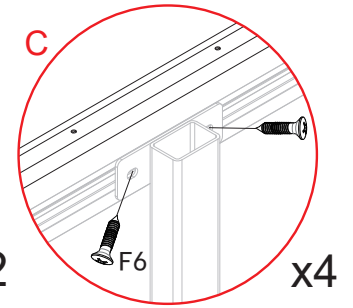
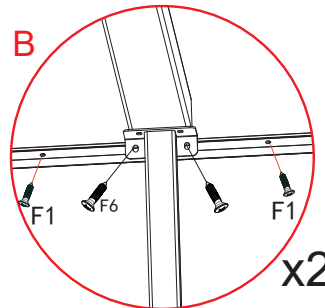
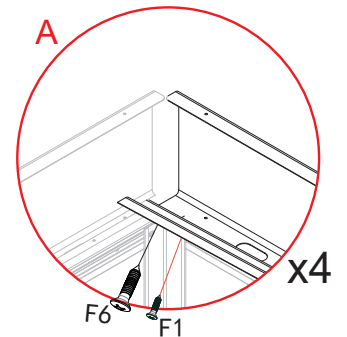
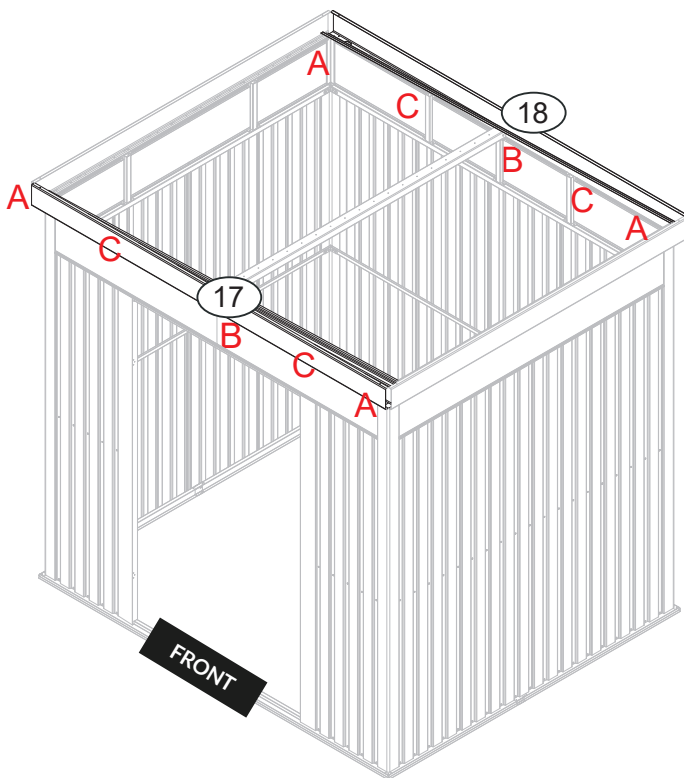
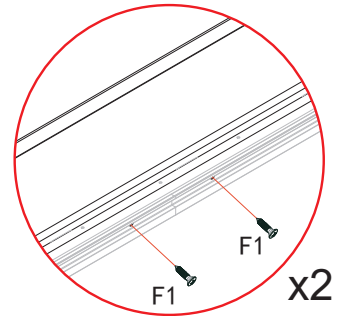
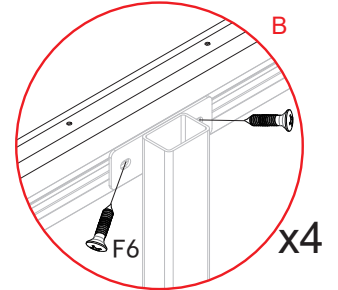
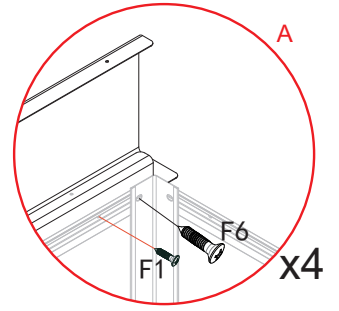

| Parts | No  | Qty |
|-------|-----|-----|
|       | 15L | 1   |
|       | 16R | 1   |
|       | F6  | 16  |
|       | F1  | 8   |



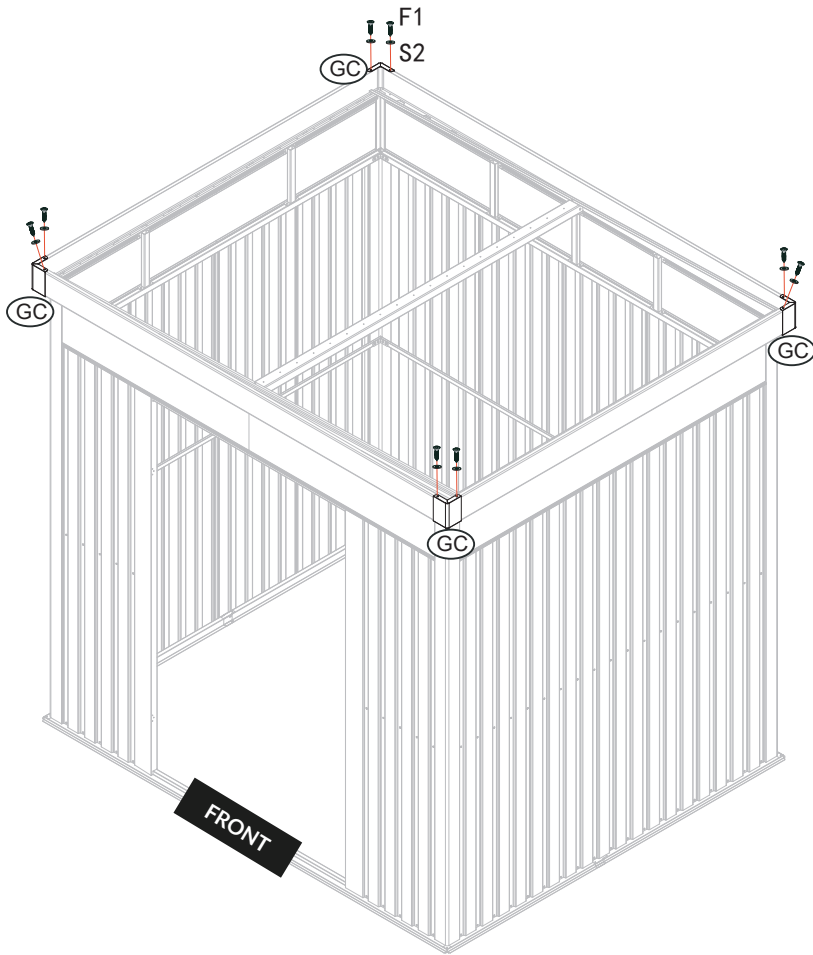



| Parts | No | Qty |
|-------|----|-----|
|       | 17 | 1   |
|       | 18 | 1   |
|       | F6 | 16  |
|       | F1 | 8   |



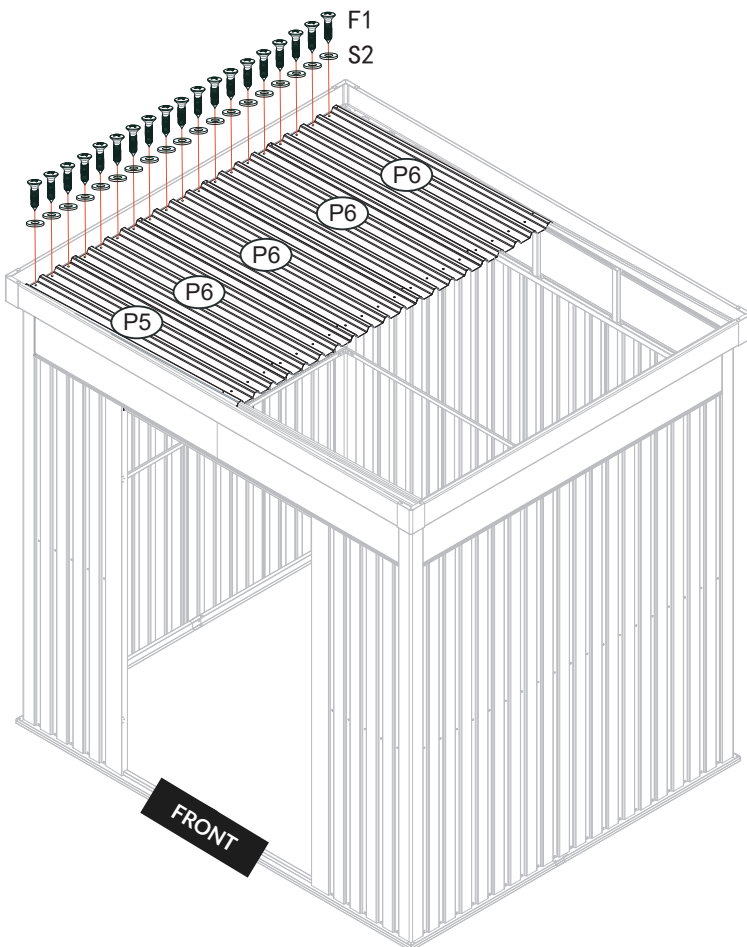
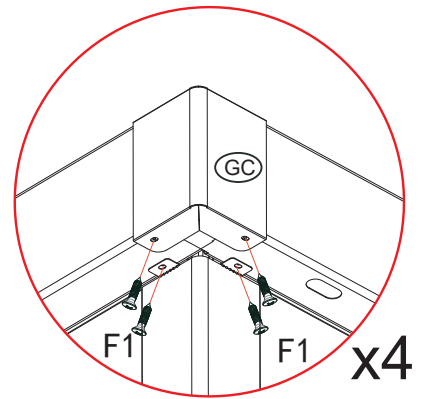





| Parts   | No | Qty |
|---|----|-----|
|  | GC | 4   |
|  | F1 | 24  |
|  | S2 | 8   |

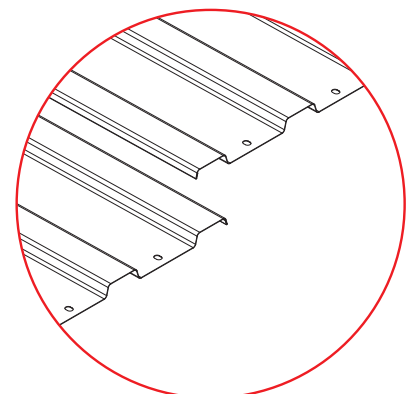

| Parts   | No | Qty |
|---|----|-----|
|  | P5 | 1   |
|  | P6 | 4   |
|  | F1 | 19  |
|  | S2 | 19  |



| Parts   | No | Qty |
|---|----|-----|
|  | P7 | 1   |
|  | P8 | 4   |
|  | F1 | 38  |
|  | S2 | 38  |

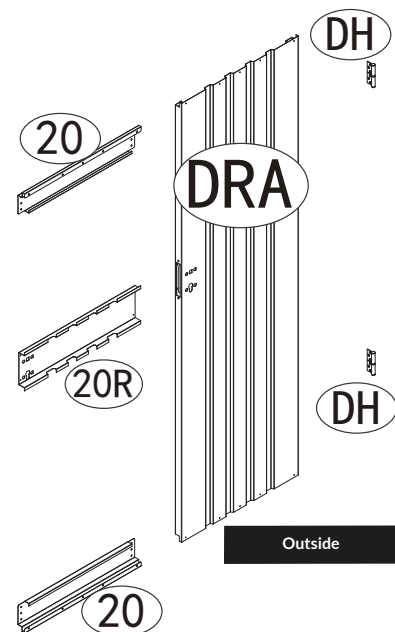
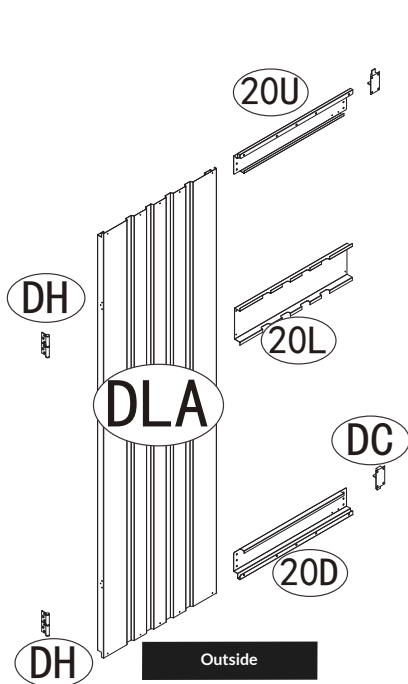
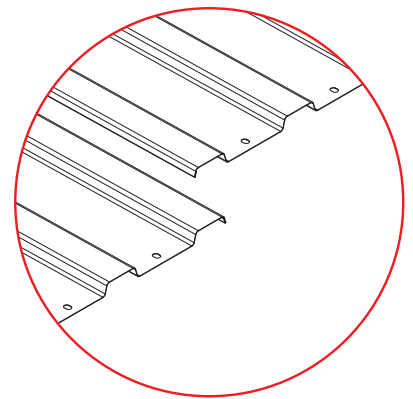
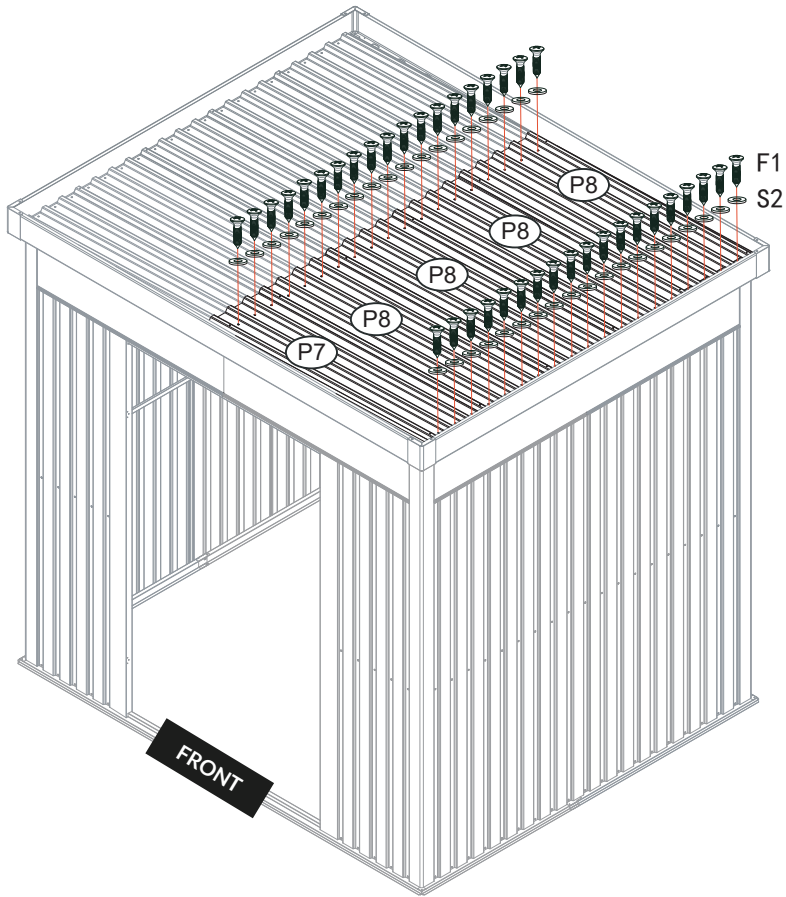

Before installing the door, prepare and organize the shown parts.

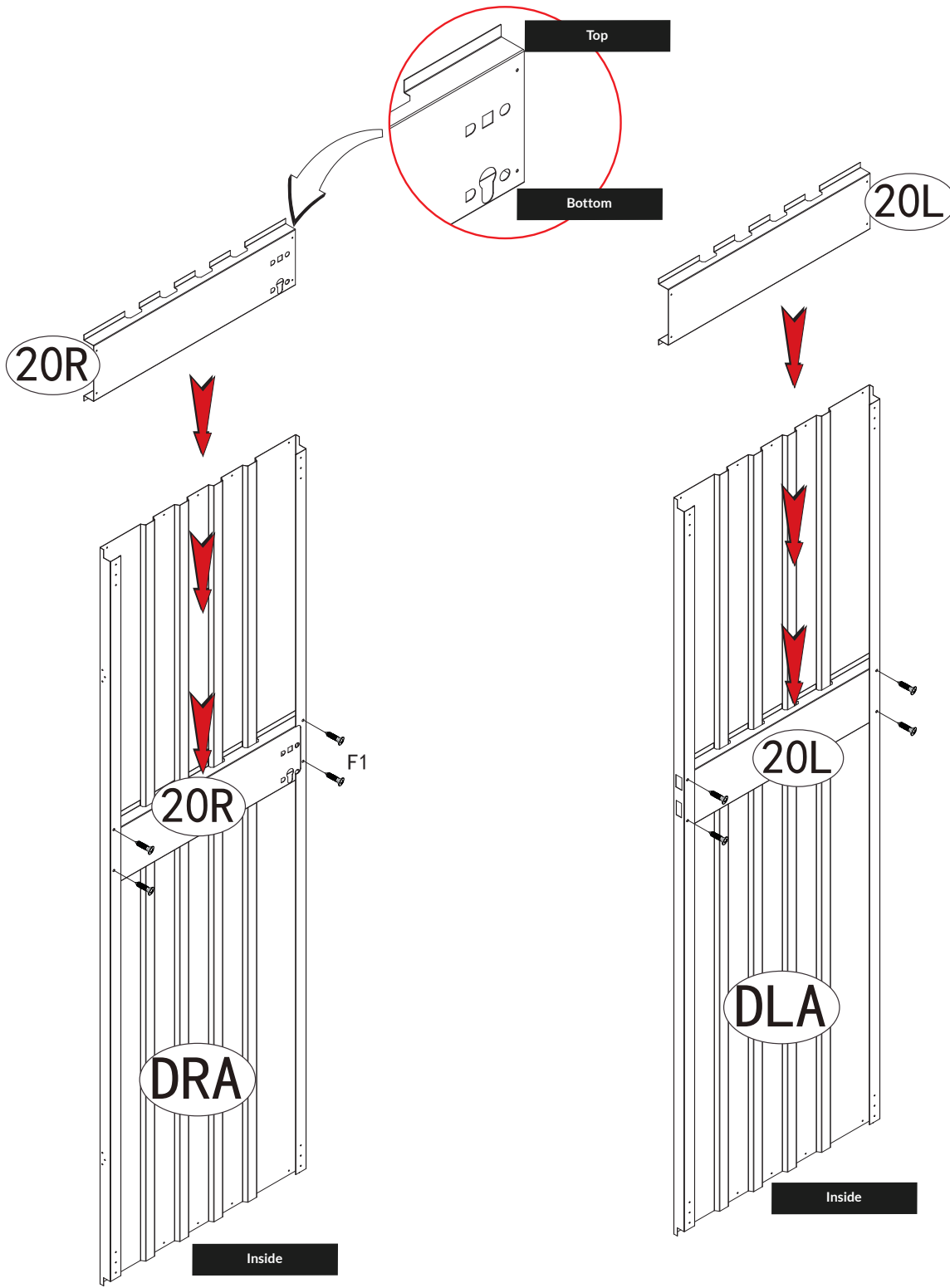

| Parts   | No | Qty |
|---|----|-----|
|  | F1 | 8   |

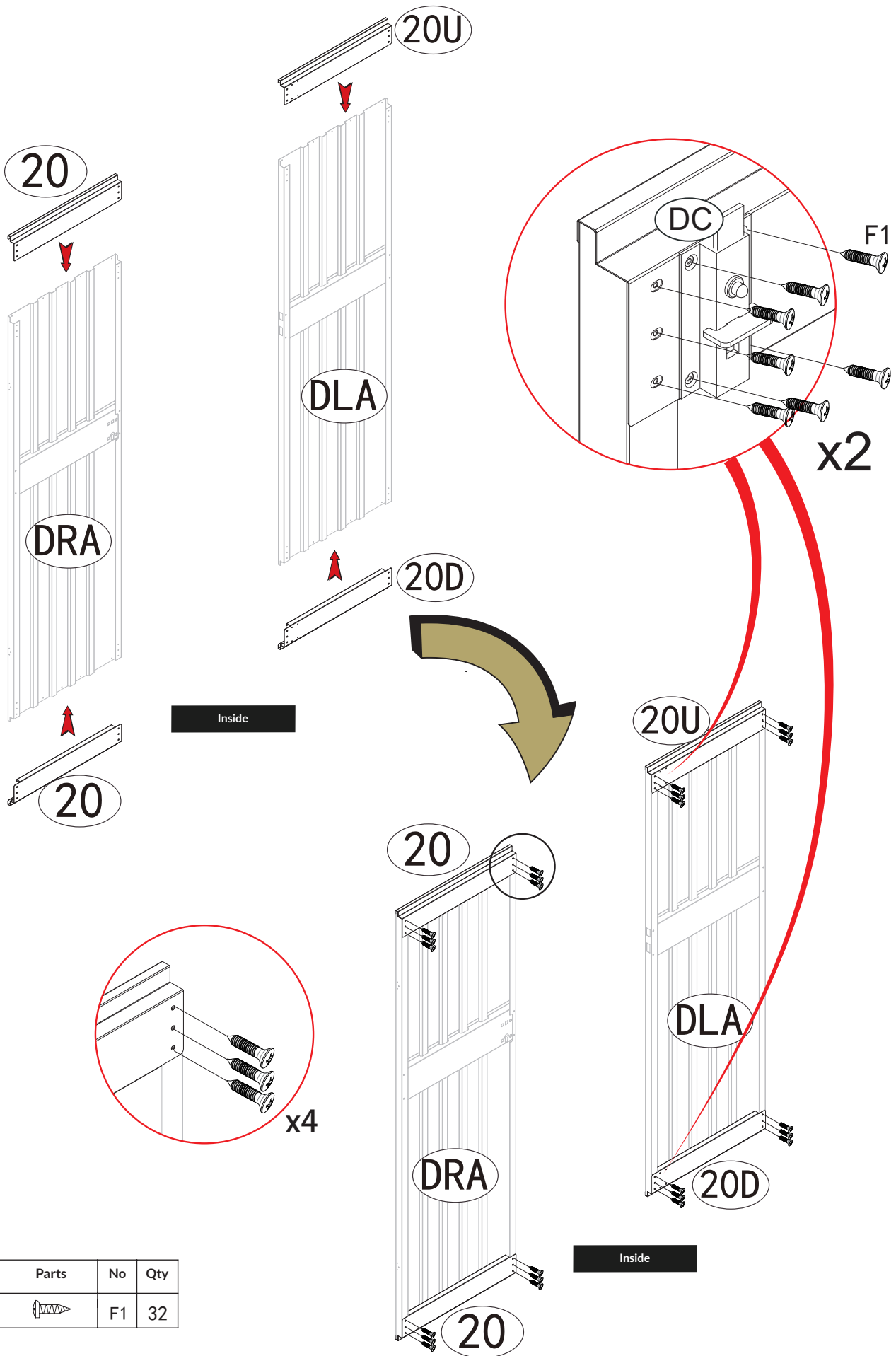

| Parts   | No | Qty |
|---|----|-----|
|  | F1 | 32  |

Please locate the following parts before installing the lock again

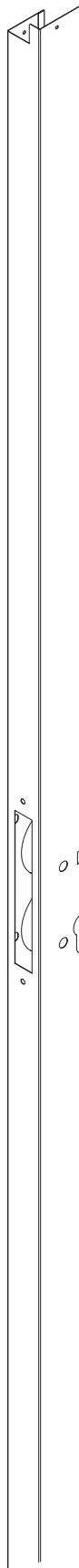
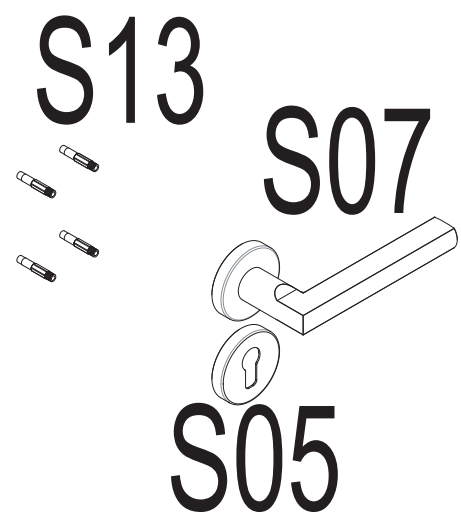
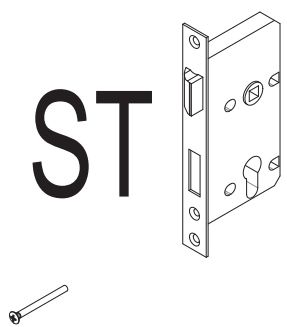
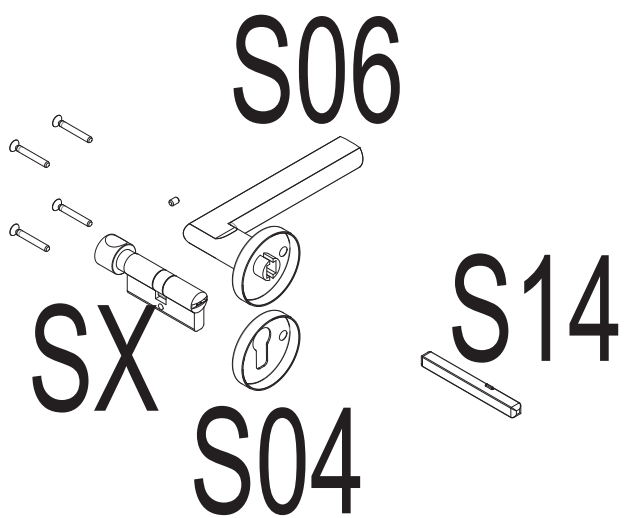

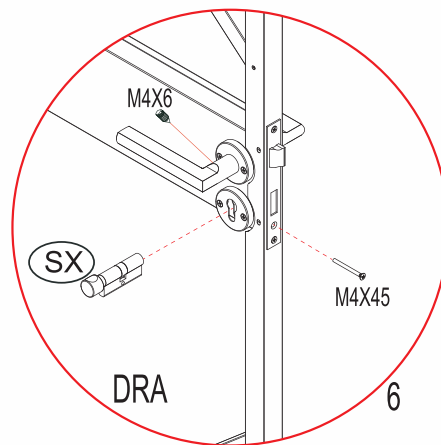
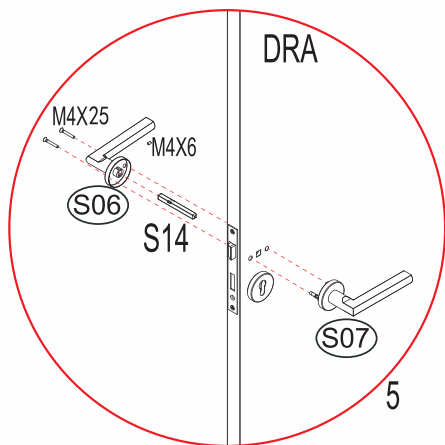
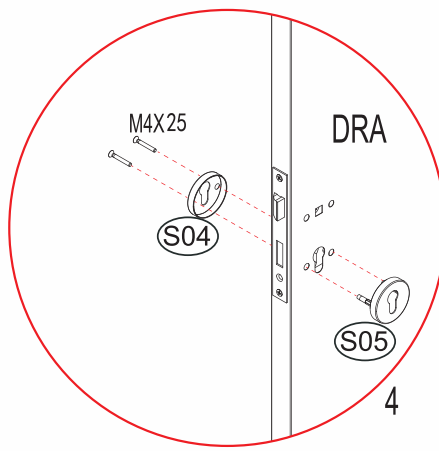
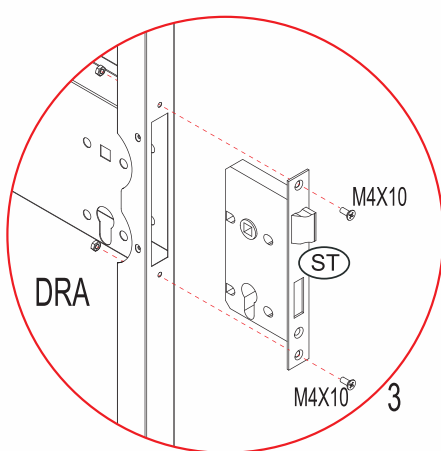
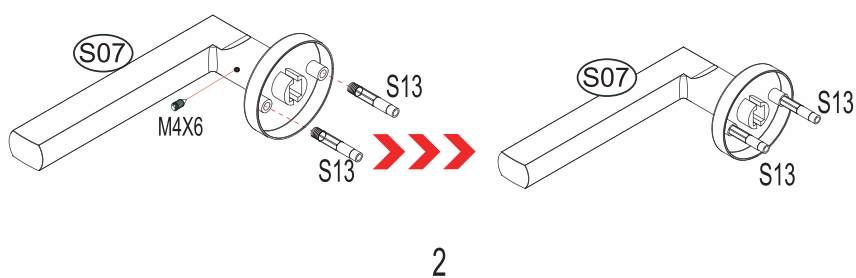
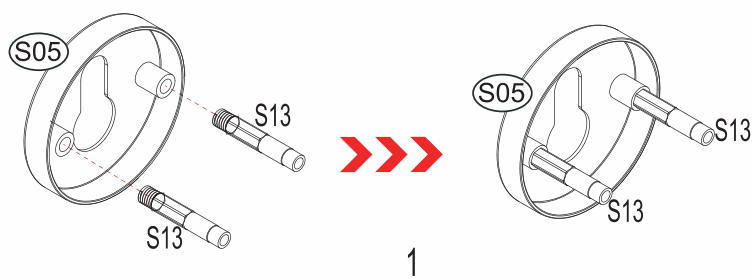

53

| Parts   | No | Qty |
|---|----|-----|
|  | F3 | 12  |

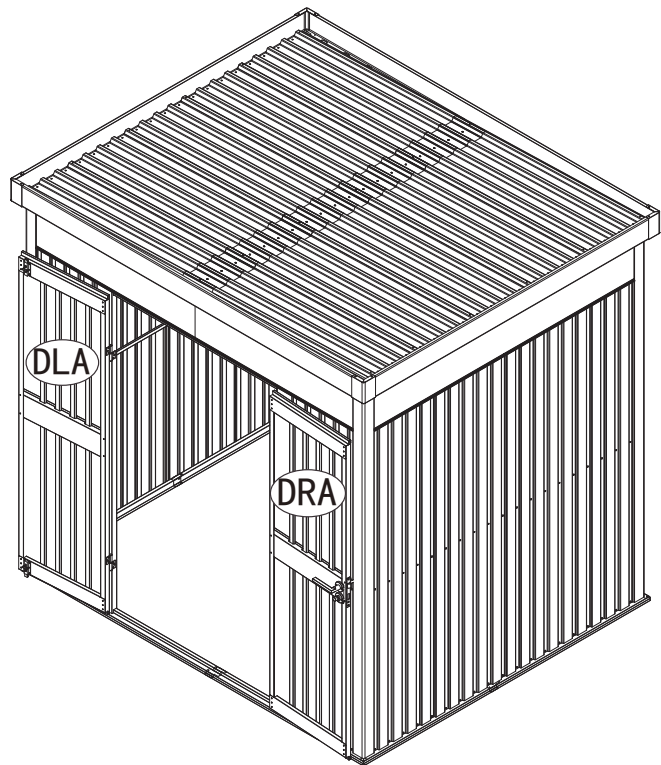
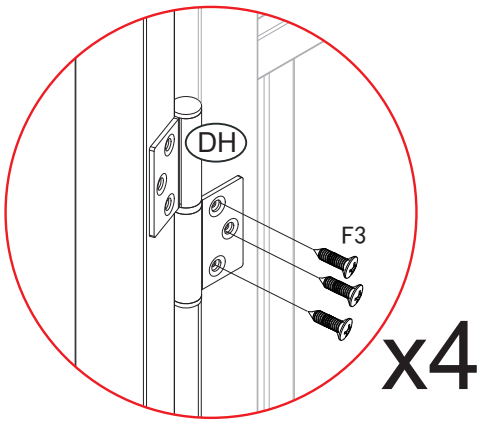

| Parts   | No   | Qty |
|---|------|-----|
|  | 6x80 | 8   |

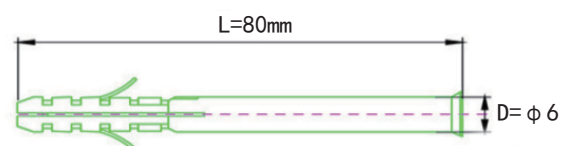
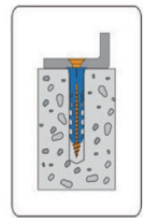
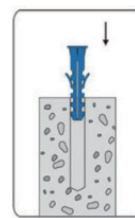
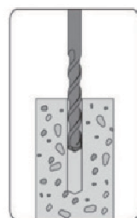
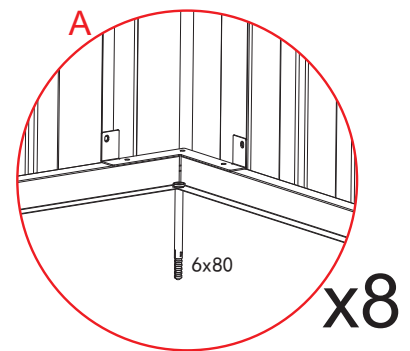
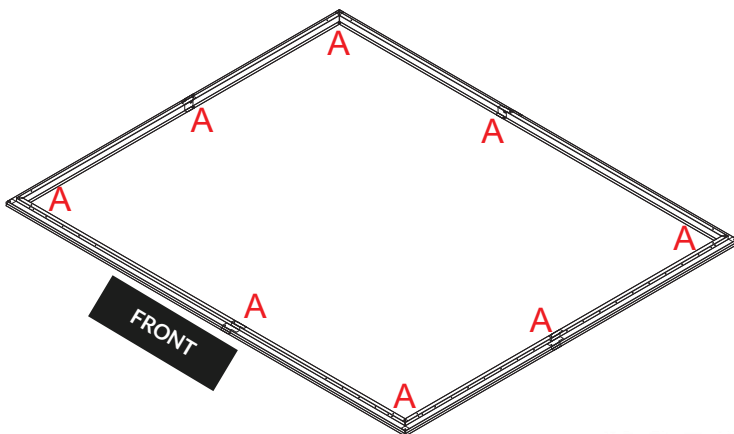

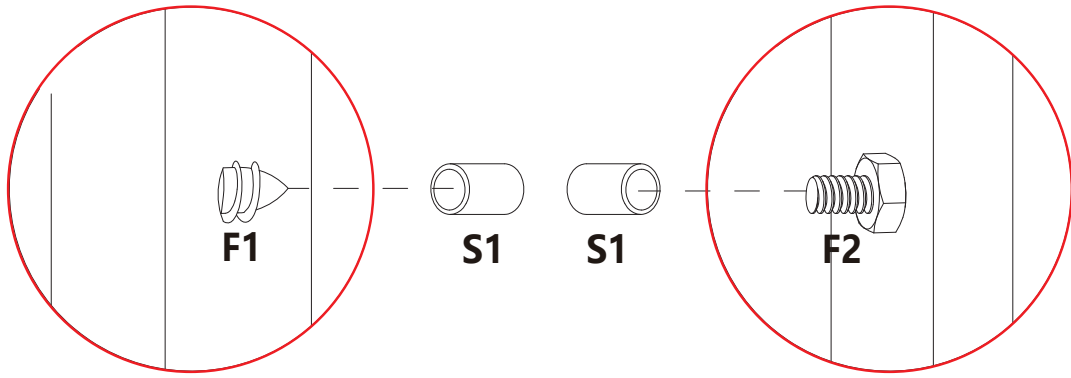

| Parts   | No | Qty |
|---|----|-----|
|  | S1 |     |

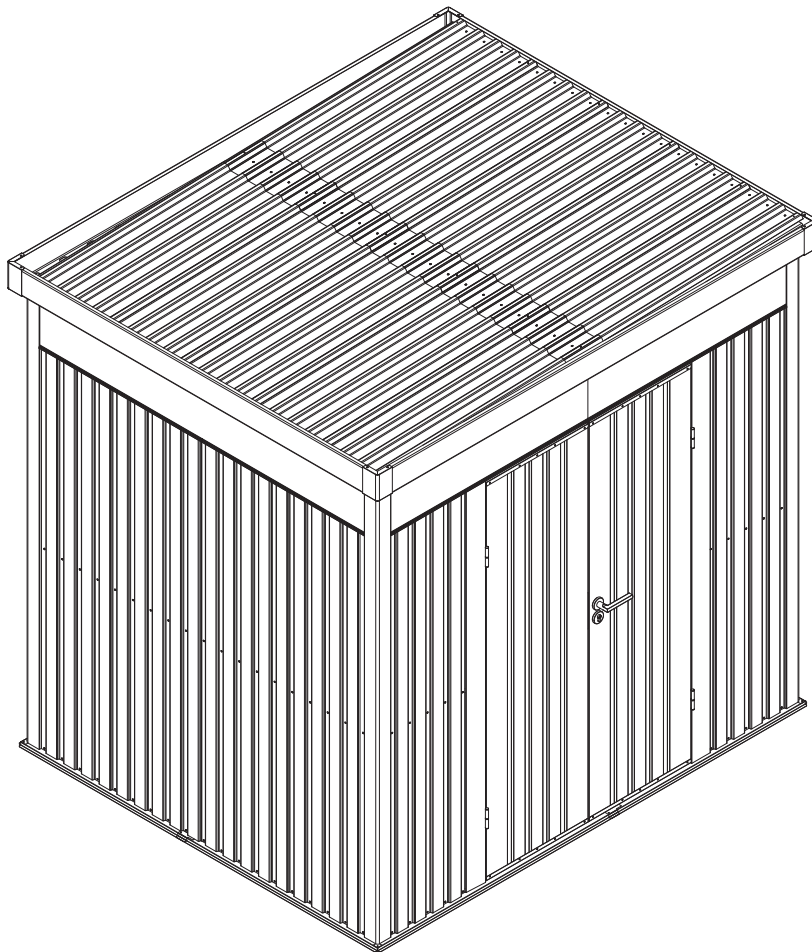



## **IMPORTANT! Keep this manual for future reference**

### **Purpose**

Metal sheds are a great option for people who want to efficiently and successfully store their garden equipment, tools or machines, whilst still on a budget. The shed is intended for outdoor use only.

### **User instructions**

Use and assembly should take place on a dry, hard and even ground. Both assembly and maintenance should be performed by adults only. 2 adults are recommended for this model to be assembled. Before use, make sure that the entire structure is firm and properly assembled and that the screws are tightened. Failure to do so may result in damage to structural elements and, consequently, in an accident and injury to users. You should not climb onto the roof of the house, as a fall from this height may result in serious injuries and in extreme cases even death. Never light the grill inside the house, do not let go of fireworks or other accessories with an open flame.

### **Cleaning and maintenance**

**Finish:** For a long lasting finish, periodically clean and wax the exterior surface. Take care of scratches as soon as you spot them on your model. Clean the area immediately with a wire brush; wash and apply repair paint as recommended by the manufacturer.

### **Roof**

Keep the roof clear of leaves and snow with a long, soft brush. Large amounts of snow on the roof can damage the house, making it dangerous to enter. In countries with heavy snowfall, roof reinforcement kits are available for most Arrow buildings, which provide additional protection against heavy snow build-up.

### **Doors**

Always keep the door guides away from dirt and other debris that prevent them from sliding easily. Every year, lubricate the door guide with a special paste or silicone spray. Try to keep the door closed and locked to prevent wind damage.

### **Joining elements**

Use all provided pads to prevent weather infiltration and to prevent metal from scratching with screws. Check your house regularly for loose bolts, nuts etc. and tighten them if necessary.

### **Moisture**

A sheet of plastic (vapor barrier) placed under the entire floor surface with good ventilation will reduce condensation and moisture.

### **Other tips**

Wash off part numbers written in ink on the panels with soap and water. Silicone seals can be used for watertight seals throughout the shed. Do not store pool chemicals in your tool shed. Flammable and corrosive materials must be stored in hermetically sealed containers.